



# PRINTING SPECIFICATIONS



## RoHS Compliant

Item Number:1208674	Drawing Number:R17102-00
Description:INSTR,INSTL,D3,Beta	Rev: A
ECR/N or LICR Number: 5113	

JDE Contact:

Phone No:

Hardware: PC  Mac  other

Software / Format (ie eps, p65, PDF etc):

Flat Size:

Finished Size:

Number of Pages:

Ink Colors:

Staple:

Drill holes (please tick): 2x  3x  4x  none  other

Proof Required by JDE: yes  no

Electronic file required by Printer: yes  no

Revision Log (SC only)			
ECR/LICR#	Revision	Description	Approvals
5113	A	Released	DB,DB,MF

Special Notes:

**Note: (UK ONLY):** To print this page only, (in MS Word Format) – select File/Print and type “S1” in “page range”, sub-menu “pages” or to print document type “S2-” in “page range”. To print document in PDF do not print this page (Page 1)

Please Return All Documents to: (please tick)

<input type="checkbox"/> JohnsonDiversey Equipment Osier Dr, Sherwood Park, Annesley, Notts. NG15 0DS (UK)	<input type="checkbox"/> JohnsonDiversey Equipment, 4 Finway, Dallow Rd, Luton (UK) LU1 1TR	<input type="checkbox"/> JohnsonDiversey Equipment 2841 Mission St. Santa Cruz, CA 95060
---	---	---

# D3000

## Installation and Operating Manual



### SAFETY



- Always wear the required Personal Protective Equipment (such as safety glasses, gloves, face shields, and aprons) when potentially exposed to any hazardous materials and when performing hazardous work tasks. Turn the dispenser off during cleaning and note that parts may be contaminated with product. If possible, flush tubing out with water prior to performing any maintenance.
- For information on products that are used in this dispenser, please carefully read the product label and Material Safety Data Sheet (MSDS).
- Refer installation and service to qualified personnel only. Installation must comply with all applicable plumbing and electrical codes.
- Disconnect all power to this unit before servicing. Servicing should only be performed by qualified service personnel.
- Electrical installation of this equipment should only be performed by trained personnel in accordance with local electrical wiring regulations (in North America, refer to NEC and CSA C22.2 CEC Part 1). Before working with this equipment, isolate it from any electrical source and lock out/tag out.
- Power transformers must be mounted in a protective safety enclosure (such as inside the dish machine).
- If the equipment is used in a manner not specified by the manufacturer, the protection provided by the equipment may be impaired.
- Only use power fittings which provide strain relief, such as cable glands, strain reliefs, or conduit. We recommend Heyco strain reliefs and corresponding lock nuts (using Heyco part numbers 3231 and 8463) or equivalent.

### PRODUCT DESCRIPTION

The D3000 is a 2 or 3-product dispensing system for use with all warewashing machines: high or low temp, conveyor or door-type, in probe, speed, or time mode. Its operation can be set up with either the three dial settings on the PCB, or a greater variety of settings with a removable programmer, the Uniview.

The Uniview must be used for a 3-product installation. The pumpbox holds either a solenoid and a pump, or two pumps, and an aux box is added if another pump is required.

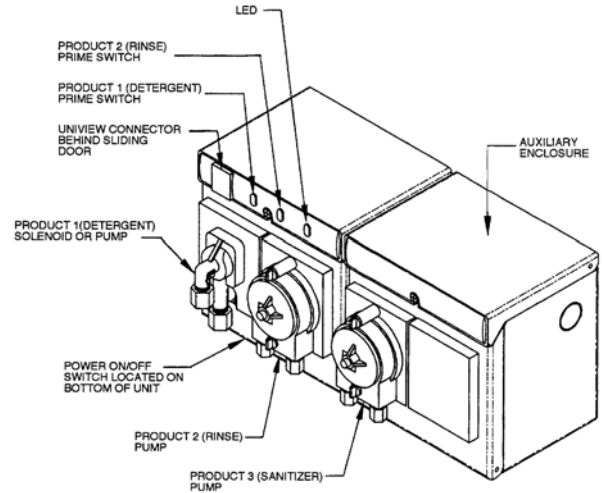

Figure 1. D3000 3-Product System

The D3000 includes a power ON/OFF switch, two prime switches, and a system-status indicator LED. Both prime switches are pressed to prime sanitizer.

### D3000 SPECIFICATIONS

#### Dimensions (D3000 Enclosure without cartridges and tubes)

Height	Width	Depth
5.4	5.3	4.4 inches
138	135	112 millimeters

#### Weight (D3000 Enclosure without cartridges and tubes)

1.6 lbs (715 gm)

#### Pollution Degree

2

#### Equipment Category

II, for indoor use

#### Ambient Temperature

41-104°F (5-40°C)

#### Altitude

Up to 2000 meters (6561 feet)

#### Maximum Relative Humidity

80% for temperatures up to 88 degrees Fahrenheit (31 degrees Celsius), decreasing linearly to 50% relative humidity at 104 degrees Fahrenheit (40 degrees Celsius)

## Enclosure Material

ABS 765

## Maximum Duty Cycle

Pump 1 = 99%

Pumps 2 & 3 = 20% (5 minutes on, 5 minutes off)

## TRANSFORMER SPECIFICATIONS

### Dimensions

Height	Width	Depth
2.2	3.6	2.5 inches
56	92	63 millimeters

### Weight

1.8 lb (800 gm)

### Electrical

Primary power 120/240 VAC, 50/60 Hz, Secondary power 24 VAC (20 VA)



*Mains supply voltage fluctuations must not exceed 10% of the nominal supply voltage.*

## OPERATION

### ALARM & INDICATOR

The internal audible alarm and the indicator lamp on the front panel together provide the following operating status information:

Power from detergent or rinse .....	Green indicator is on continuously
Detergent or rinse feeding .....	Green indicator is flashing slowly
Rinse delay .....	Green indicator is flashing rapidly
Detergent low .....	Red indicator is flashing rapidly and alarm is pulsing (Probe modes only)
Overfeed stop.....	Red indicator and alarm are on continuously

## PHYSICAL INSTALLATION

### MOUNTING THE UNIT

Select a place to mount the unit. Avoid steam and other sources of moisture, such as from spray or splash. Do not subject the unit to temperatures outside the range 2°C to 49 °C (36°F to 120°F).

Mount the D3000 on the wall using the 2 keyhole slots on the interior back panel, plus the third mounting hole. An anchor template is provided in the Appendix. For dishwasher top mounting applications please use bracket 018224.

### Installing the Conductivity Probe

If available and suitable for the application, use the washer manufacturer's predrilled access hole. Otherwise, punch a 2.2 cm (7/8-inch) hole through the wash tank in a location that

will provide accurate sampling of the detergent solution.

Typically, you would mount the probe about 10 cm (4 inches) above the bottom of the tank, away from any heater elements, corners or any mechanical components (such as water-level floats). Smooth the edges (so gaskets will seal well) and mount the probe.

### Installing the Detergent Bulkhead Fitting

Punch a hole in the wash tank in a suitable location above the water level line. For best results, mount the fitting directly above the point where the probe is located. All necessary installation parts for a typical installation are included in the installation kit supplied with the D3000, or with the powder/solid detergent hopper.

### Connecting Chemical Supply Lines

Connect the 1/4-inch ( or 6 mm) line to the nut on the left (suction side) of the pump squeeze tubes. Tighten the nuts on the fittings. Make sure the connection is airtight. Run the lines to the chemical drums, and secure the end of each supply line into its respective container. Use a snap-in standpipe for liquid detergent lines.

The snap-in standpipe is a rigid three-quarter round U-shaped tube section 46 cm (18 inches) long. Cut the line at a 45° angle. Press the feed end of the line into the open part of the U. Leave the bottom of the standpipe slightly lower than the inlet of the line.



### Product 1 (Detergent) Pump and Product 3 (Sanitizer) Output Lines

Connect the 1/4-inch (or 6 mm) line to the nut on the right side of the detergent or sanitizer pump squeeze tubes. Tighten the nut on the fitting. Run the feed line to the detergent bulkhead fitting.

### Product 2 (Rinse) Pump Output Line

Connect the 1/8-inch (or 4 mm) line to the nut on the rinse pump squeeze tube. Tighten the nut on the fitting. Run the feed line to the plastic injector/check valve fitting.



*Although the rinse pump is capable of pumping against 2.8 bar (40 psi), we advise against operating at this level. The rinse pump tubing life will be severely shortened. Most dishwasher manufacturers specify no more than 1.8 bar (25 psi) in the washer rinse line, and the water pressure should always be below this specification to ensure optimum performance and results.*

### PLUMBING CONNECTIONS TO WATER SOLENOID

Solenoids are used to supply water to a powder or solid detergent hopper. The compression fittings on the solenoid inlet and outlet accept either 6 mm (1/4-inch) plastic line or 6 mm (1/4-inch) copper tube. Follow the flow arrows on the solenoid when making connections. Consult the instructions supplied

with the detergent hopper. Regulate water pressure to the hopper in the range from 1.4 to 2.1 bar (20 to 30 psi).

## WIRING

Disconnect all power and then locate the electrical circuits on the dishmachine which provide power. Power must be supplied to the D3000 when the dishmachine is in operation (wash and rinse cycle) and must be turned off when the dishmachine is off.

Mount two transformers in the protective enclosure (typically inside the dishmachine) and connect the primary legs of each power source to them as shown in the table below. Because the transformers step down the power, the secondary wires which provide power to the D3000 are low voltage (24 VAC). Connect the secondary wires (brown and blue wires in a white sheath) to the WHITE terminal block inside the dispenser.

	240 VAC Power Source	120 VAC Power Source
Primary Connection (transformer input wires)	Red and white (black must be safely terminated)	Black and white (red must be safely terminated)



The secondary output voltage wires from the transformer to the dispenser **must** connect to the white plastic terminal block “24 VAC” connections in the pumpbox. Do not connect them directly to the green “Trigger” connector on the PCB; connecting them to the green terminal block will destroy the PCB, as the green terminal block only handles contact closures.

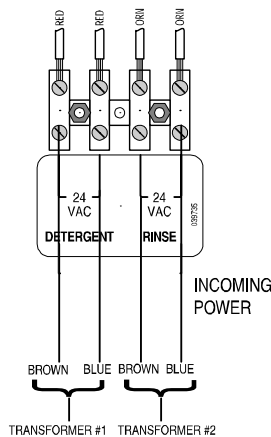
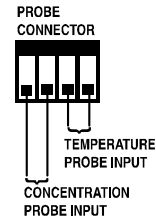

Figure 4. Pumpbox terminal block

## PROBE CONNECTIONS

You may use either a temperature-compensated probe or a standard conductivity-only probe with the D3000. The D3000’s PCB has four connections for the probe installation. With a conductivity-only probe, use only the left two connectors.



1. Bring the probe wires into the D3000 through the bottom access hole.
2. Remove the probe connector from the PCB and loosen the compression screws.
3. Install the wire connectors to the probe.
4. Insert the conductivity wires from the probe into the two left positions of the connector and tighten the screws.
5. Insert the temperature probe wires into the right connector (if temperature probe is used).
6. Insert the probe connector into its socket on the PCB.

## AUX BOX SANITIZER PUMP

1. Remove the knockouts between the units by closing the lid to provide support and knocking out the plastic circle with a large screwdriver and rubber mallet
2. Install the conduit connector in the aux box kit between the two enclosures to lock them together
3. Route the aux pump wires to the SANPMP connector on the D3000 PCB.
4. Press both prime buttons on the D3000 enclosure to prime the sanitizer pump

## QUICK SETUP KNOBS

Setting up the D3000 requires using either the potentiometer black knobs on the PCB or the Uniview programmer. This section describes how to program the unit with the quick setup knobs.

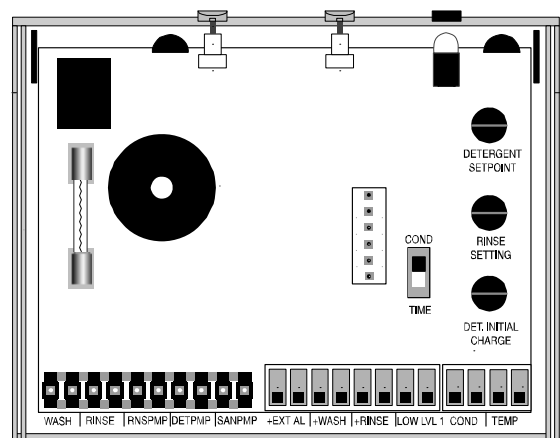

The default operating mode is conductivity/probe mode. To change the mode to time/probeless, change the switch on the PCB from “COND” to “TIME”. Adjust the knobs per the following chart to program the D3000:

Knob	Conductivity Mode	Time Mode
Detergent Setpoint	Concentration setpoint 0-70 Beta units	Detergent Recharge 0-30 seconds at 99% speed
Rinse Setting	Rinse Speed 0-99% while trigger is on	Rinse Run Time 0-30 seconds
Det. Initial Charge		Det. Initial Charge 0-90 seconds

Please note that using the knob and switch setting is not required if you are programming the unit with a Uniview. Similarly, if you program the unit with the knobs, you don't need to attach a Uniview.

## UNIVIEW OPERATION

The Uniview programmer connects directly to the D3000 via a phone-type cord through the communications port. Data is transferred to and from the D3000 using the Uniview. The Uniview is used to program the NA3000, but it is not required for D3000 operation. Disconnect the Uniview after programming the D3000.

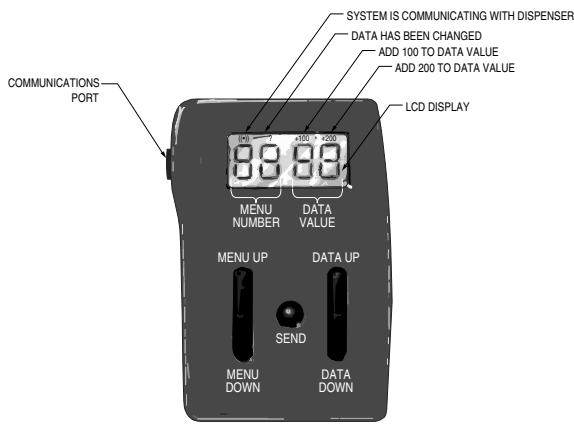

Figure 2. Uniview

### HOW TO USE UNIVIEW

- Ensure power is on to the D3000 and the Uniview cable is plugged into the D3000 PCB
- Hold down data up/data down to change a value by increments of 10.
- A check mark appears above the Menu Number whenever a setting has been changed but not saved.
- Remember to push the “send” button after changing a setting, or it will not be saved.
- Remember to change menu 23 from 0 “quick setup knob controls” to 1 “Uniview control”



*When programming with the Uniview, the first menu setting you must change is menu 23 to change from knob potentiometer control to Uniview control. Until you make this change and send it to the D3000, the D3000 will reject all attempts to change other settings.*



*When any value rises above 99, the Uniview will indicate +100 or +200 in the upper right. When a value is set outside the valid range, it will be rejected and the minimum or maximum will be displayed and used. Pressing the send key when viewing a read-only menu such as the probe reading will cause the programmer to display “EE”. If you change a value and then press the menu key without pressing send, the check mark will flash to remind you to press send before changing the menu#; pressing a menu button twice will change the menu selected without saving the new setting.*

The programmed settings with Uniview for conductivity and time modes are in the following chart. For information on the rarely used “speed mode” please consult our website training information for D3000.

Menu	Conductivity Mode (Probe) default mode	Timed Mode (Probeless)	Speed Mode (Probeless)
1	1	2	3
2	1 – Conveyor 2 – Door default = 1	1 – Conveyor 2 – Door 3 – Door with external power default = 1	1 – Conveyor 2 – Door 3 – Door with external power default = 1
3	Tank Concentration with C3M (0-70 Beta Units, Hi/Lo)	---	---
4	Concentration Set Point (10-70 Beta Units) default = 5	Detergent Recharge (0-20 seconds) default = 5	Detergent Recharge Speed (0-99%) default = 5
5	---	Detergent Initial Charge (0-240 seconds) default = 30	Detergent Initial Speed (0-99%) default = 30
6	Rinse Delay (0-240 sec) default = 0	Rinse Delay (0-240 sec) default = 0	Rinse Delay (0-240 sec) default = 0
7	Rinse Speed (0-99%) default = 10%	Rinse Speed (0-99%) default = 10%	Rinse Speed (0-99%) default = 10%
8	Rinse Run Time (0-240 sec) default = 0	Rinse Run Time (0-240 sec) default = 0	Rinse Run Time (0-240 sec) default = 0
9	Wash Temperature (0-100 degrees C)	---	---
10	Alarm Volume (0-5, min-max) default = 5	Alarm Volume (0-5, min-max) default = 5	Alarm Volume (0-5, min-max) default = 5
11	---	---	---
12	---	---	---
13	Detergent Speed (0-99%) default = 99%	Detergent Speed (0-99%) default = 99%	---

Menu	Conductivity Mode (Probe) default mode	Timed Mode (Probeless)	Speed Mode (Probeless)
14	Sanitizer Feed 0 = on with rinse 1 = on with detergent 2 = on with rinse, low level stops all pumps 3 = on with detergent, low level stops all pumps default = 0	Sanitizer Feed 0 = on with rinse 1 = on with detergent 2 = on with rinse, low level stops all pumps 3 = on with detergent, low level stops all pumps default = 0	Sanitizer Feed 0 = on with rinse 1 = on with detergent 2 = on with rinse, low level stops all pumps 3 = on with detergent, low level stops all pumps default = 0
15	Sanitizer Speed (0-99%) default = 0%	Sanitizer Speed (0-99%) default = 0%	Sanitizer Speed (0-99%) default = 0%
16	PCB ID Code default = 5	PCB ID Code default = 5	PCB ID Code default = 5
17	---	---	---
18	Rack Count High (0-240) Most significant 3 digits Door counts after rinse stops Conveyor counts after 20 seconds of accumulated rinse time Max rack count = 24,000 default = 0	Rack Count High (0-240) Most significant 3 digits Door counts after rinse stops Conveyor counts after 20 seconds of accumulated rinse time Max rack count = 24,000 default = 0	Rack Count High (0-240) Most significant 3 digits Door counts after rinse stops Conveyor counts after 20 seconds of accumulated rinse time Max rack count = 24,000 default = 0
19	Rack Count Low (0-99) Least significant 2 digits default = 0	Rack Count Low (0-99) Least significant 2 digits default = 0	Rack Count Low (0-99) Least significant 2 digits default = 0
20	Drain Count (0-240) Only counts drains if conductivity probe is connected default = 0	---	---
21	Conductivity Range 0 = LO 1 = HI default = 1	---	---
22	Tank Concentration without C3M or averaging (0-70 Beta Units, Hi/Lo)	---	---
23	Control Source 0 = POTS 1 = Uniview default = 0	Control Source 0 = POTS 1 = Uniview default = 0	Control Source 0 = POTS 1 = Uniview default = 0
24	Firmware Version	Firmware Version	Firmware Version

## SCREEN EXAMPLES, BOTH MODES

The following screen examples apply to all modes.

### Mode Selection (Menu 1)

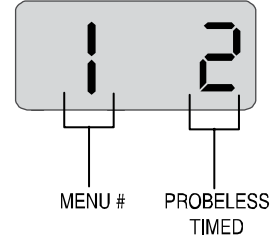

This menu lets you designate probe or probeless operation by inputting a 1 for Probe Mode, 2 for Probeless Timed Mode or 3 for Probeless Speed Mode.

Use the DATA UP and DATA DOWN keys on the Uniview to set the number to 1 or 2. Press SEND to send the data to the dispenser.

The example shows the dispenser set for Probe Mode operation.

### Machine Type (Menu 2)

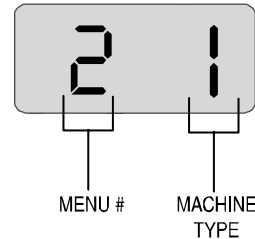

Input 1 if the dishmachine is a conveyor. If the dishmachine is a door type, input 2 if the power source is from the dishmachine during the dispensing cycles, or 3 if the power is on all the time from an external source. In the latter case, triggers from the dishmachine will request the cleaning products (see **Appendix C** for details on programming with triggers). The example shows a conveyor type dishmachine.

### Product 3 (Sanitizer) Feed Configuration (Menu 14)

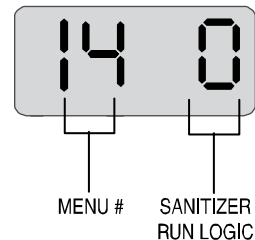

Sanitizer can be set to feed with the rinse (by inputting a 0) or with detergent (by inputting a 1). Use the DATA UP and DATA DOWN keys to select 1 or 0, then press SEND. When set to run with rinse, the sanitizer pump runs at the selected speed during the delay and the rinse cycle. When set to run with detergent, the sanitizer pump runs only when the detergent pump runs. The example is a system set up to feed sanitizer with the rinse.

**Product 3 (Sanitizer) Pump Speed (Menu 15)**

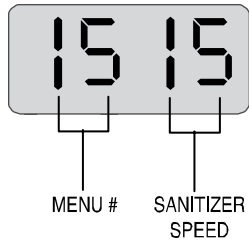

This menu allows you to set the pump speed of the sanitizer pump. Speed is measured in the percentage of maximum speed applied to the pump. Use the DATA UP and DATA DOWN keys to input a percentage, then press SEND. The example shows the pump speed at 15%.

**PCB ID Code (Menu 16)**

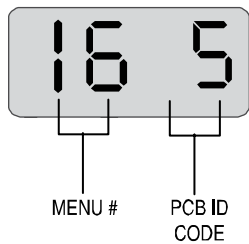

This menu displays an identification code related to the PCB's software.

**Rack counts (Menus 17-19)**

The rack count goes up every time the rinse pump turns on when running with a door machine, or every 20 seconds with a conveyor.

Because the Uniview display is small, the rack count is displayed across screens 17, 18, & 19. Together, the following screens show a rack count of 1,251,672.

	17 displays digits for values in the millions, hundred thousands, and ten thousands. This screen shows a value of 1,25#,###
	18 displays digits for the values in the 1,000's and the hundreds. This screen shows a value of #,##1,6##
	19 displays digits for the values in the 10's and 1's. This screen shows a value of 72.

Please note the rack count is not manually resettable. It "rolls over", restarting the count once it's reached 2,400,000.

**CONDUCTIVITY MODE SCREEN EXAMPLES**

**Reading Wash Tank Concentration (Menu 3)**

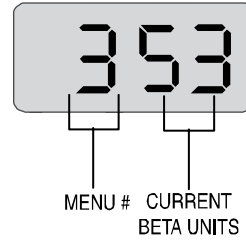

This menu only displays the current wash tank concentration. To set the conductivity setpoint, use Menu 4.

The example shows a wash tank conductivity of 53 Beta Units.

**Concentration Setpoint (Menu 4)**

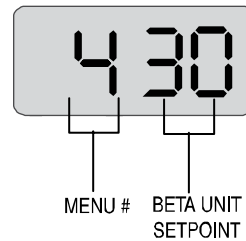

When using a conductivity probe (menu 1 set to 1), the D3000 can automatically adjust concentration to meet a setpoint. This menu lets you input that concentration setpoint from Uniview. The setpoint range is between 0 and 70 Beta Units. To determine the correct setpoint, use the method described below.

The example shows a conductivity setpoint of 30 Beta Units.

**Drain Count (Menu 20)**



This screen indicates the number of drains that occur in conductivity mode. It counts up to 240, and then resets. In the example above, the drain count is 212. The objective is to be able to track whether an account is draining the tank enough.



*Many screens differ depending on whether you select time or conductivity mode, so they follow in two sections, one for conductivity screens and one for time screens.*

**Concentration Adjustment**

Use this method to determine a concentration setpoint.

1. Fill the wash tank with water, make sure the water is heated to the correct wash temperature and then turn on the wash motor to agitate the water.
2. From the Uniview (menu 4), use the DATA UP and DATA DOWN keys to input a Beta Unit value of 0, then press SEND. If the concentration level in Menu 3 reads "Lo", the dispenser will pump chemical.

3. Change to Menu 3 to view the wash tank concentration.
4. Press the prime switch on the D3000 to allow detergent to feed until a desired concentration reading is reached. This will require feeding and waiting at intervals to allow the Uniview to display the concentration changes.
5. When the desired concentration is reached, change back to menu 4, use the DATA UP and DATA DOWN keys to set the concentration and press SEND. The D3000 will automatically adjust to meet this concentration setpoint.

### Feed Cycle

The D3000 controls the feed cycle automatically. It prevents overshooting by pulsing on and off. After several runs, the system learns the correct pulse rate for the particular installation.

### Low Detergent Alarm Test

A low-detergent alarm is initiated if the setpoint is not met after five complete feed cycles. The alarm consists of a flashing red LED and a pulsing audible alarm. If, after five more complete cycles the setpoint is not met, the D3000 goes into overfeed-stop mode, shutting the detergent pump or solenoid off and initiating a continuous audible alarm and solid red LED. To check the low-detergent alarm, follow the procedures below.

1. Remove the detergent SnapHead pump or turn the water supply off (if using a solenoid). This will prevent chemical from entering the wash tank.
2. Run the dishmachine. The alarm should turn on after five feed cycles, and the pump will turn off after five additional feed cycles.
3. Turn power off to reset the alarm. Reinstall the SnapHead pump or turn on the solenoid water supply as required.



*When an alarm has been activated after five feeds, it cannot be cancelled unless the setpoint is reached.*

4. Check the concentration and add time if necessary.
5. Rerun the test as necessary to perfect the concentration.

### Product 2 (Rinse) Delay Time (Menu 6)

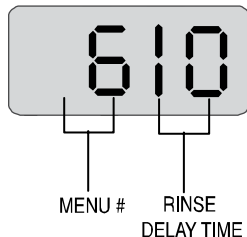

The rinse delay is the time between when the dispenser receives a signal that the rinse cycle has begun, and when it begins pumping chemical. The rinse delay range is 0 to 240 seconds. Use the DATA UP and DATA DOWN keys to input the appropriate delay time, then press SEND.

The example shows a rinse delay of 10 seconds.

### Product 2 (Rinse) Speed (Menu 7)

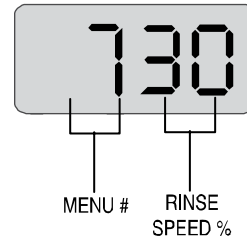

The rinse speed refers to the percentage of total pump speed (0 - 99). Use the DATA UP and DATA DOWN keys to input a percentage, then press SEND.

The example shows the rinse speed at 30%.

### Product 2 (Rinse) Run Time (Menu 8)

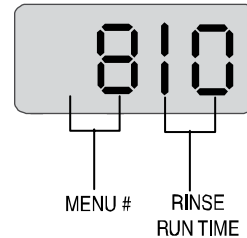

This refers to the total time the rinse pump will run (0 to 240 seconds). Use the DATA UP and DATA DOWN keys to set a rinse run time, then press SEND. If conveyor was selected in menu 2, the rinse will automatically be set to zero. This means the rinse will run continuously after the delay time. The example shows 10 seconds.

### Reading the Wash Temperature (Menu 9)

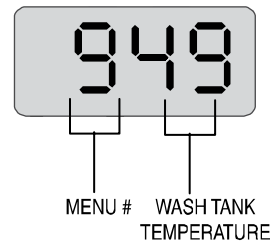

This menu allows you to view the actual wash temperature from Uniview when a temperature-compensated probe is used. This menu is read-only and shows temperature in degrees Celsius.

The example shows a wash temperature of 49°C. Refer to the table below for converting to 0°F.

Celsius	Fahrenheit
0	32
10	50
20	68
25	77
30	86
35	95
40	104
45	113
50	122
55	131
60	140
65	149
70	158
80	176
90	194
100	212

Converting Celsius to Fahrenheit

### Audible Alarm (Menu 10)

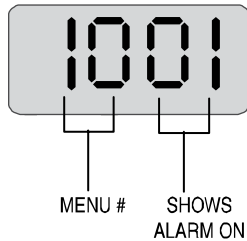

This menu shows whether the audible alarm is on or off. If the rightmost digit is 0, the alarm is off. 1 through 5 indicate that the alarm is on (1 = the lowest volume level, 5 = the highest volume level).

### Product 1 (Detergent) Pump Speed (Menu 13)

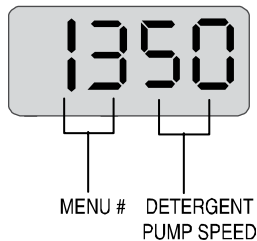

Product 1 pump speed can be varied from 0 to 99% of maximum speed. The purpose of this control is to adjust the pump to best suit the viscosity of the product to be delivered.

The example shows a pump speed of 50% of maximum.

### Product 3 (Sanitizer) Feed Configuration (Menu 14)

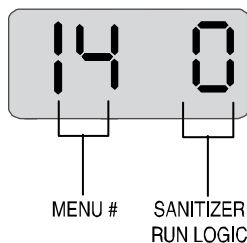

Sanitizer can be set to feed with the rinse (by inputting a 0) or with detergent (by inputting a 1). Use the DATA UP and DATA DOWN keys to select 1 or 0, then press SEND. When set to run with rinse, the sanitizer pump runs at the selected speed during

the delay and the rinse cycle. When set to run with detergent, the sanitizer pump runs only when the detergent pump runs. The example is a system set up to feed sanitizer with the rinse.

### Product 3 (Sanitizer) Pump Speed (Menu 15)

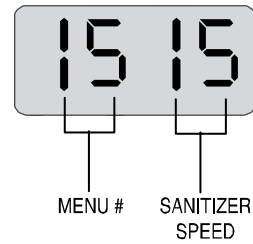

This menu allows you to set the pump speed of the sanitizer pump. Speed is measured in the percentage of maximum speed applied to the pump. Use the DATA UP and DATA DOWN keys to input a percentage, then press SEND. The example shows the pump speed at 15%.

## TIME MODE SCREEN EXAMPLES

### Recharge Time (Menu 4)

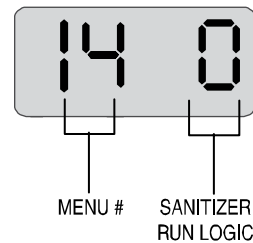

The recharge time is the amount of time the pump or solenoid is on during a recharge for each cycle. The recharge time range is between 0 and 20 seconds.

The example shows a detergent recharge of 10 seconds.



*When using the D3000 in the probeless mode on a pump-type door machine, the detergent as well as the rinse agent is injected during the rinse portion of the wash cycle. To accomplish this, connect the machine's rinse solenoid to both sides of the terminal block.*

The following will test the concentration when the rinse solenoid is activated.

1. Use the DATA UP and DATA DOWN keys to input an approximate time value, then fill the wash tank with water heated to the correct wash temperature.
2. Turn on the washer for no longer than 20 seconds to dispense the recharge amount of detergent and agitate the solution.
3. Check the concentration and add time if necessary.
4. Rerun the test as necessary to perfect the concentration.

### Initial Charge Time (Menu 5)

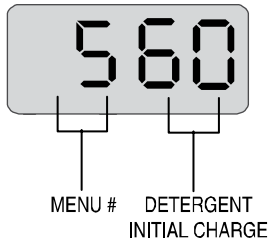

The initial charge is the amount of time the detergent pump or solenoid will be on when initially filling the tank. This initial charge will occur 20 seconds after the power is applied and after the normal recharge. Its purpose is to get the wash tank concentration up quickly. For single-tank, probeless systems, input a time between 0 and 240 seconds. For probeless dump and fill systems, input a 0 (initial charge is not used).

Use the DATA UP and DATA DOWN keys to input the initial charge time, then press SEND.

The example displays an initial charge time of 60 seconds.

### Product 2 (Rinse) Delay Time (Menu 6)

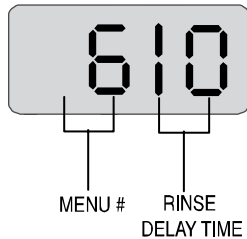

The rinse delay is the time between when the dispenser receives a signal that the rinse cycle has begun, and when it begins pumping chemical. The rinse delay range is 0 to 240 seconds. Use the DATA UP and DATA DOWN keys to input the appropriate delay time, then press SEND.

The example shows a rinse delay of 10 seconds.

### Product 2 (Rinse) Speed (Menu 7)

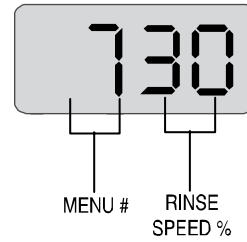

The rinse speed refers to the percentage of total pump speed (0 - 99). Use the DATA UP and DATA DOWN keys to input a percentage, then press SEND. The example shows the rinse speed at 30%.

### Product 2 (Rinse) Run Time (Menu 8)

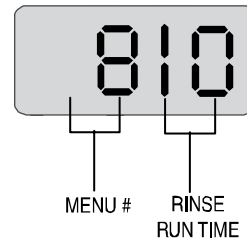

This refers to the total time the rinse pump will run (0 to 240 seconds). Use the DATA UP and DATA DOWN keys to set a rinse run time, then press SEND. If conveyor was selected in menu 2, the rinse will automatically be set to zero (0). This means the rinse will run continuously after the delay time. The example shows 10 seconds.

## TROUBLESHOOTING

Extensive troubleshooting information is available in our training presentations on our website at [beta-technology.com](http://beta-technology.com).

### UNIVIEW PROBLEMS

The telephone cable (code #090358) that is used on the Uniview displays the following symptoms when one of the wires is cut or damaged.

**Black wire:** Uniview display is blank. PCB appears to function.

**Red wire:** Uniview reads data but will not send data to PCB. PCB operates normally.

**Green wire:** Uniview shows 4 bars on display. PCB operates normally.

**Yellow wire:** Uniview display is blank. LED on PCB is always on instead of flashing, and no other functions work.

If these problems occur, replace the Uniview cable. If you don't have a spare cable, use a telephone cable.

# APPENDIX

## D3000 WALL ANCHOR LOCATING TEMPLATE

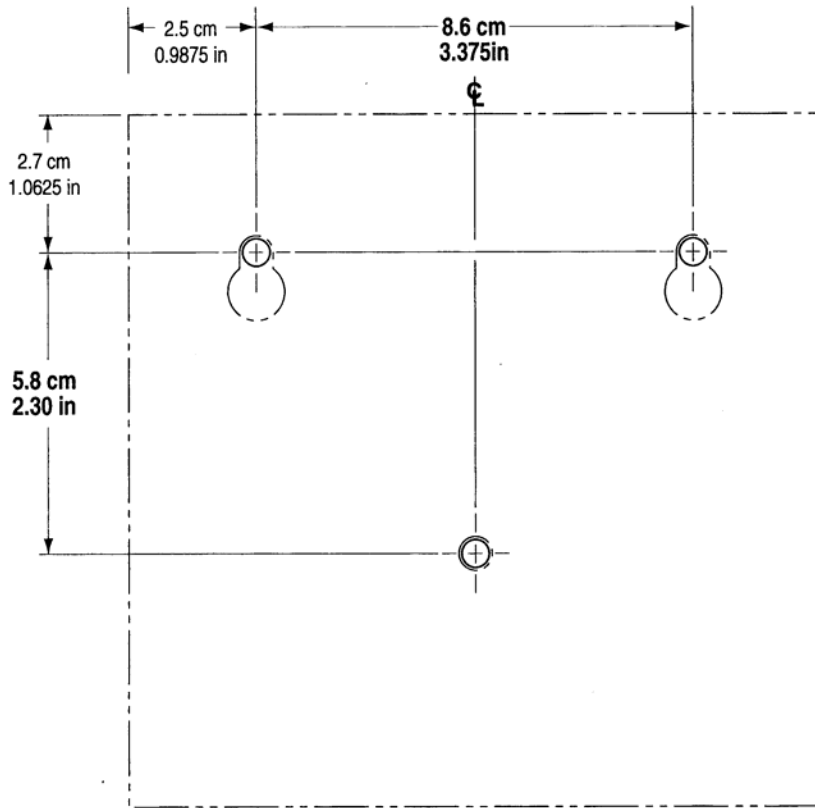

HOLES IN ENCLOSURE  
0.54 cm (0.212 in)

TEMPLATE TO SCALE -  
SUITABLE FOR DIRECT LAYOUT



Beta Technology  
2841 Mission Street  
Santa Cruz • CA  
U.S.A. • 95060-2142

TEL • 831 • 426 • 0882  
TEL • 800 • 858 • 2382  
FAX • 838 • 423 • 4573  
FAX • 800 • 221 • 8416

<http://www.beta-technology.com>  
[sales@beta-technology.com](mailto:sales@beta-technology.com)

**Beta Technology is ISO 9001 Certified**