

D3000 Installation Guide



Safety



Always wear personal protective equipment such as gloves and safety glasses when working with potentially hazardous chemicals.



Electrical installation must be performed by personnel trained in accordance with local regulations.



This is a quick Installation Guide designed to help professional dispensing-equipment installers set up the D3000 system. If you would like more detailed documentation, complete with all safety and installation requirements, please contact Customer Service or your local Technical Customer Service Representative..

Parts Identification

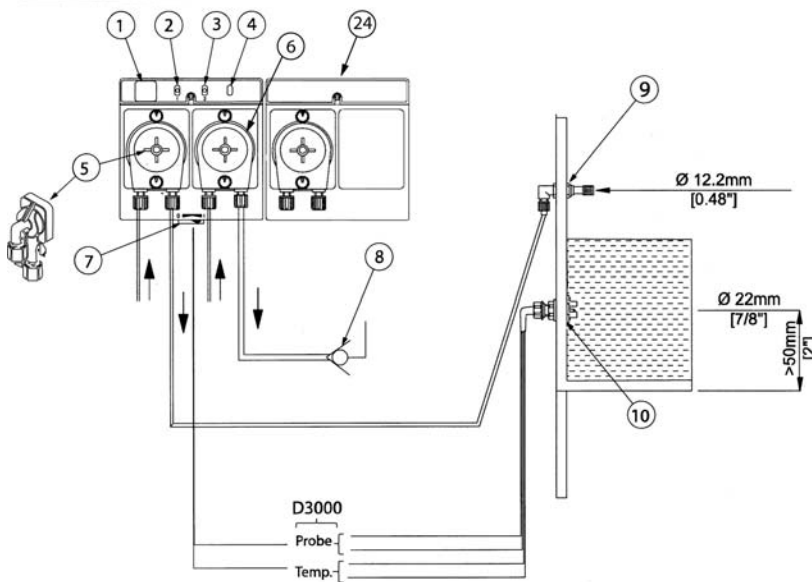

Figure 1. D3000, complete installation

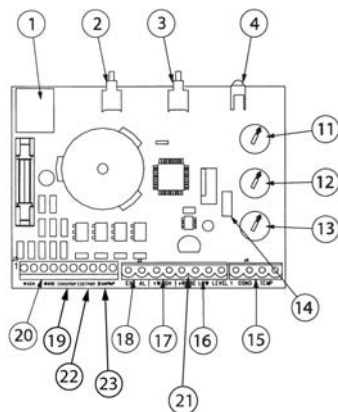

Figure 2. D3000 PCB connections

Part Identification

1. Uniview Socket
2. Prime Detergent* (Product 1)
3. Prime Rinse* (Product 2)
4. Power/Alarm Indicator
5. Product 1 Pump or Solenoid
6. Product 2 Pump
7. On/Off Switch
8. Non-Return Valve (for Time/Speed dosing)
9. Bulkhead Fitting
10. Conductivity Probe
11. Detergent Set Point Dial
12. Rinse Setting Dial
13. Detergent Initial charge Dial
14. Conductivity or timed option (potentiometer setting)
15. Probe Connector
16. Depletion Input
17. Optocoupler/Trigger inputs
18. External Alarm output
19. Rinse Pump Connection
20. Internal Connections
21. Pressure Switch Input (for Conveyer mode)
22. Det Pump Connection
23. Optional third pump connection (Sanitizer)
24. Optional 3rd (auxiliary) Pump Box

*Press 2+3 simultaneously to prime 3rd Pump

Mounting D3000

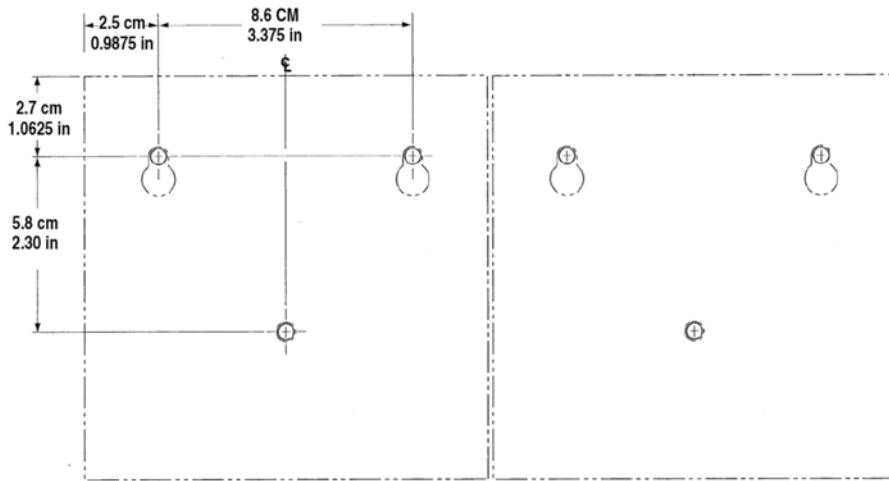

Figure 3. D3000 mounting dimensions

- Mount D3000 on a vertical, flat surface away from steam and spray. We recommend using the mounting template on the last page of this document.
- Operating temperature range for D3000 is 36°F (2°C) to 104°F (40°C).

Circuit Board Connections

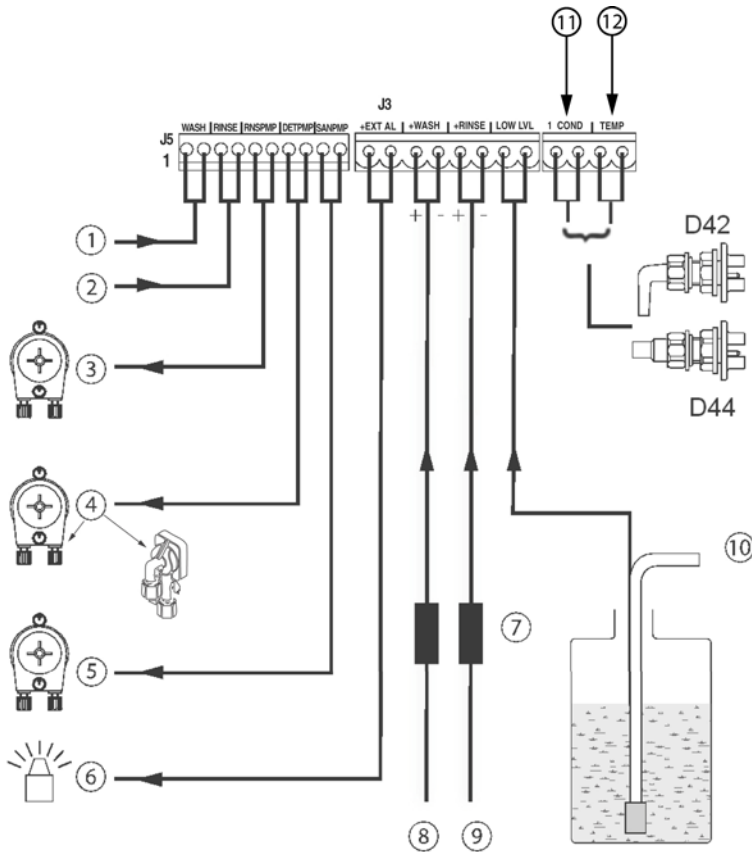
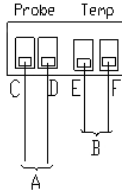

Figure 4. D3000 PCB wiring

Part Identification

1. Wash 24V Power
2. Rinse 24V Power
3. Rinse Pump
4. Detergent Pump or Solenoid
5. Third Pump
6. Remote Alarm
7. Optocouplers
8. Wash Trigger
9. Rinse Trigger
10. Depletion Lance
11. Connection for Conductivity Probe
12. Connection Temperature Probe

Probe Connections



- A. Conductivity Probe
- B. Temperature Probe
- C. Blue Wire
- D. Red Wire
- E. Yellow Wire
- F. Green Wire

Transformer Power (for External Transformer)

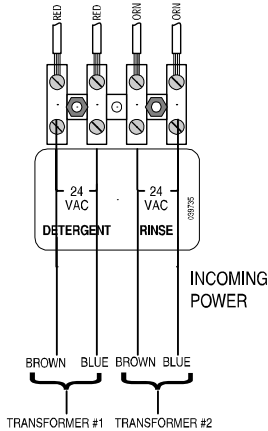

1. Mount 2 transformers in protective enclosure (typically inside dishmachine).
2. Connect primary legs of each power source to the transformers as shown in the table below.
3. Connect secondary wires (brown and blue wires in white sheath) to the WHITE terminal block inside the dispenser. These wires provide low voltage (24 VAC) power.

	240 VAC Power Source	120 VAC Power Source
Primary Connection (transformer input wires)	Red and white (black must be safely terminated)	Black and white (red must be safely terminated)



The secondary output voltage wires from the transformer to the dispenser **must** connect to the white plastic terminal block "24 VAC" connections in the pumpbox. Do not connect them directly to the green "Trigger" connector on the PCB; connecting them to the green terminal block will destroy the PCB, as the green terminal block only handles contact closures.

Figure 5. Incoming power connections for external transformer dispensers

Transformer Power (for Internal Transformer)

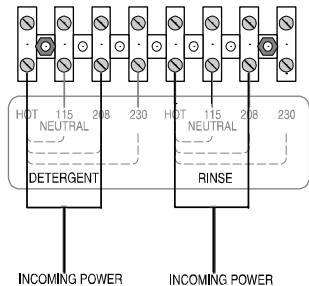

Connect the two legs of each power source to the appropriate terminals on the white terminal block inside the dispenser.

Figure 6. Incoming power connections for internal transformer dispensers (showing 208 VAC power source)

Low Level Alarm and Pressure Switch Connections

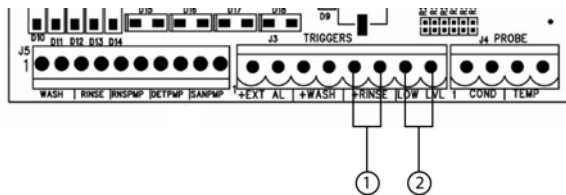

1. Pressure switch connection
2. Low level switch connection

- The low-level alarm will cause the D3000 to flash red when the depletion lance detects chemical is getting low.
- Connect depletion lance wires to pins 7 and 8 on the J3 terminal.
- If using a pressure switch (for conveyer machines), connect to pins 5 and 6 on the J3 terminal.

Figure 7. D3000 PCB, Pressure Switch and Low Level Connections

Remote Trigger Signals (Optional)

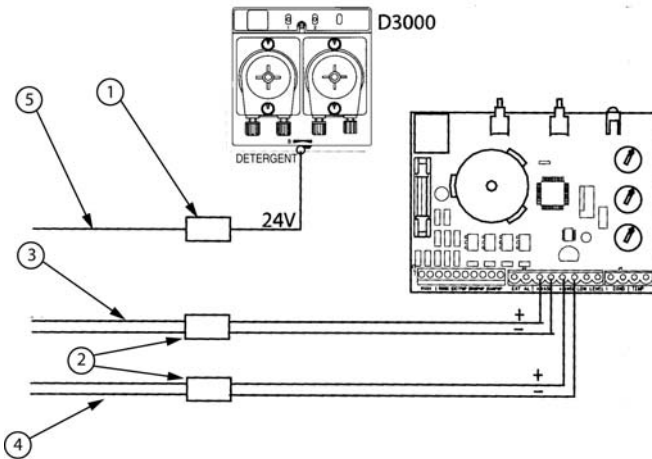

Figure 8. Remote Trigger Connections

When using Timed or Speed mode with the Uniview, and have selected “Door” with external power, the D3000 is triggered to dose by a closed-contact interface on J3 pins 3 and 4 for wash and 5 and 6 for rinse. You can use either an optocoupler or standard relay as this interface.

1. Transformer
2. Optocouplers
3. Fill valve
4. Rinse valve
5. Dishwasher on

Adding an Auxiliary Pump Box

Auxiliary sanitizer pump boxes are available and can be ordered separately (code #1208821).

Programming

Using Potentiometer Dials

Knob	Conductivity Mode	Time Mode
Detergent Setpoint	Concentration setpoint 0-70 Beta units	Detergent Recharge 0-30 seconds at 99% speed
Rinse Setting	Rinse Speed 0-99% while trigger is on	Rinse Run Time 0- 30 seconds
Det. Initial Charge		Det. Initial Charge 0-90 seconds



You can use the potentiometer dials to program the standard 2 pumps (detergent and rinse). If you will be adding a third pump for sanitizer, you will need to program it with the Uniview (see menus 14 and 15 under **Programming: Using Uniview**). You can then use Uniview menu 23 to change back to “0” (potentiometer mode).

The default operating mode is conductivity/probe mode. To change the mode to time/probeless, change the switch on the PCB from “COND” to “TIME” (See Figure 9). Adjust the knobs per the chart on the left to program the D3000.

1. Detergent setpoint dial
2. Rinse setting dial
3. Detergent initial charge dial
4. Conductivity or timed option (potentiometer setting)

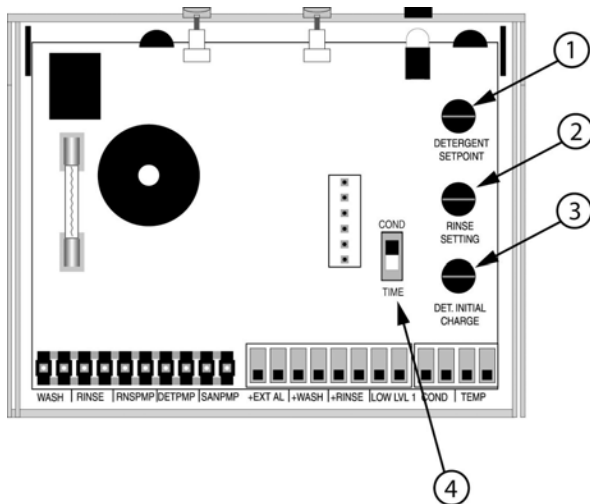

Figure 9. D3000 PCB with potentiometer dials

Programming Using Uniview

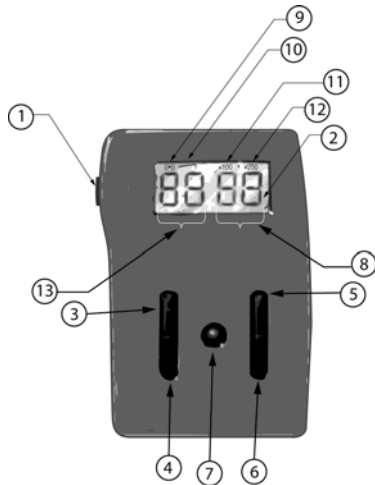

Figure 10. Uniview

Uniview can be used to program the D3000. A cable connects the Uniview to the D3000 through the communications port. Disconnect the Uniview after programming the D3000.

Uniview Components

1. Communications port
2. LCD Display
3. Menu "UP" button
4. Menu "DOWN" button
5. Data "UP" button
6. Data "DOWN" button
7. "Send" button

Display Data

8. Data value
9. System is communicating with dispenser.
10. Data has been changed.
11. Add 100 to data value.
12. Add 200 to data value
13. Menu number

Uniview Menus

Menu	Conductivity Mode (Probe) default mode	Timed Mode (Probeless)	Speed Mode (Probeless)	Compatibility Mode
1	1	2	3	4
2	1 - Conveyor 2 - Door default = 1	1 - Conveyor 2 - Door 3 - Door with external power default = 1	1 - Conveyor 2 - Door 3 - Door with external power default = 1	D5000 Compatible 0 = No (24 menus) 1 = Yes (16 menus) default = 0
3	Tank Concentration with C3M (0-70 Beta Units, Hi/Lo)	---	---	
4	Concentration Set Point (0-70 Beta Units) default = 5	Detergent Recharge (0-20 seconds) default = 5	Detergent Recharge Speed (0-99%) default = 5	
5	---	Detergent Initial Charge (0-240 seconds) default = 30	Detergent Initial Speed (0-99%) default = 30	
6	Rinse Delay (0-240 sec) default = 0	Rinse Delay (0-240 sec) default = 0	Rinse Delay (0-240 sec) default = 0	
7	Rinse Speed (0-99%) default = 10%	Rinse Speed (0-99%) default = 10%	Rinse Speed (0-99%) default = 10%	
8	Rinse Run Time (0-240 sec) default = 0	Rinse Run Time (0-240 sec) default = 0	Rinse Run Time (0-240 sec) default = 0	
9	Wash Temperature (0-100 degrees C)	---	---	
10	Alarm Volume (0-5, min-max) default = 5	Alarm Volume (0-5, min-max) default = 5	Alarm Volume (0-5, min-max) default = 5	
11	---	---	---	
12	---	---	---	
13	Detergent Speed (0-99%) default = 99% NOTE: For detergent solenoid applications using a bowl, speed MUST be no lower than 99%.	Detergent Speed (0-99%) default = 99%	---	

Menu	Conductivity Mode (Probe) default mode	Timed Mode (Probeless)	Speed Mode (Probeless)	
14	Sanitizer Feed 0 = on with rinse 1 = on with detergent 2 = on with rinse, low level stops all pumps 3 = on with detergent, low level stops all pumps default = 0	Sanitizer Feed 0 = on with rinse 1 = on with detergent 2 = on with rinse, low level stops all pumps 3 = on with detergent, low level stops all pumps default = 0	Sanitizer Feed 0 = on with rinse 1 = on with detergent 2 = on with rinse, low level stops all pumps 3 = on with detergent, low level stops all pumps default = 0	
15	Sanitizer Speed (0-99%) default = 0%	Sanitizer Speed (0-99%) default = 0%	Sanitizer Speed (0-99%) default = 0%	
16	PCB ID Code default = 5	PCB ID Code default = 5	PCB ID Code default = 5	
17	Rack Count High (0-240) digits 7,6,5 Door counts when rinse turns on Conveyor counts after 20 seconds of accumulated rinse time Max rack count = 2,400,000 default = 0	Rack Count High (0-240) digits 7,6,5 Door counts when rinse turns on Conveyor counts after 20 seconds of accumulated rinse time Max rack count = 2,400,000 default = 0	Rack Count High (0-240) digits 7,6,5 Door counts when rinse turns on Conveyor counts after 20 seconds of accumulated rinse time Max rack count = 2,400,000 default = 0	
18	Rack Count Middle (0-99) digits 4 & 3 default = 0	Rack Count Middle (0-99) digits 4 & 3 default = 0	Rack Count Middle (0-99) digits 4 & 3 default = 0	
19	Rack Count Low (0-99) digits 2 & 1 default = 0	Rack Count Low (0-99) digits 2 & 1 default = 0	Rack Count Low (0-99) digits 2 & 1 default = 0	
20	Drain Count (0-240) Only works in conductivity mode with conductivity probe default = 0	---	---	
21	Conductivity Range 0 = LO 1 = HI default = 1	---	---	
22	Tank Concentration without C3M or averaging (0-70 Beta Units, Hi/Lo)	---	---	
23	Control Source 0 = POTS 1 = Uniview default = 0	Control Source 0 = POTS 1 = Uniview default = 0	Control Source 0 = POTS 1 = Uniview default = 0	
24	Firmware Version default = 1	Firmware Version default = 1	Firmware Version default = 1	

EU DECLARATION OF CONFORMITY



Application of Council Directive: Under 89/336/EEC as amended by 92/31/EEC and 93/68/EEC

Standards to which

Conformity is Declared:

In accordance with EN 61326:1997 including amendments 1-3, Emission
EN 61326:1997 Class B radiated and conducted emissions
EN 61000-3-2:1995 Harmonic Current emissions
EN 61000-3-3:1995 Voltage Fluctuations and Flicker

In accordance with EN 61326:1997 including amendments 1-3, Immunity
EN 61000-4-2:1998 Electrostatic Discharge: ± 4 kV contact, ± 8 kV air
EN 61000-4-3:1998 Radiated Immunity: 3V/m
EN 61000-4-4:1995 Electrical Fast Transients/Burst: ± 1 kV AC, ± 0.5 kV I/O
EN 61000-4-5:1995 Surge: ± 0.5 kV differential mode, ± 1 kV common mode
EN 61000-4-6:1996 Conducted Immunity: 3V
EN 61000-4-11:1994 Supply Dips and Variations: 100%

Manufacturer's Name: Beta Technology

Manufacturer's Address: 2841 Mission St.
Santa Cruz, CA 95060-5705, USA

Manufacturer's Address in the EU: 4 Finway, Dallow Road, Luton
Bedfordshire, LU1 1TR

Type of Equipment: Chemical Dispensing System

Product Name: D3000 System

Model(s): D3000-24
D3 SANTZR
UNIVIEW

I understand and hereby declare that the equipment specified above conforms to the above Directive(s) and Standard(s).

Place: Santa Cruz, CA, USA Signature: 

Date: 08-May-2008 Full Name: Cedric Chan

Title: Engineering Manager

1208941 (R17265-00 Rev. B)

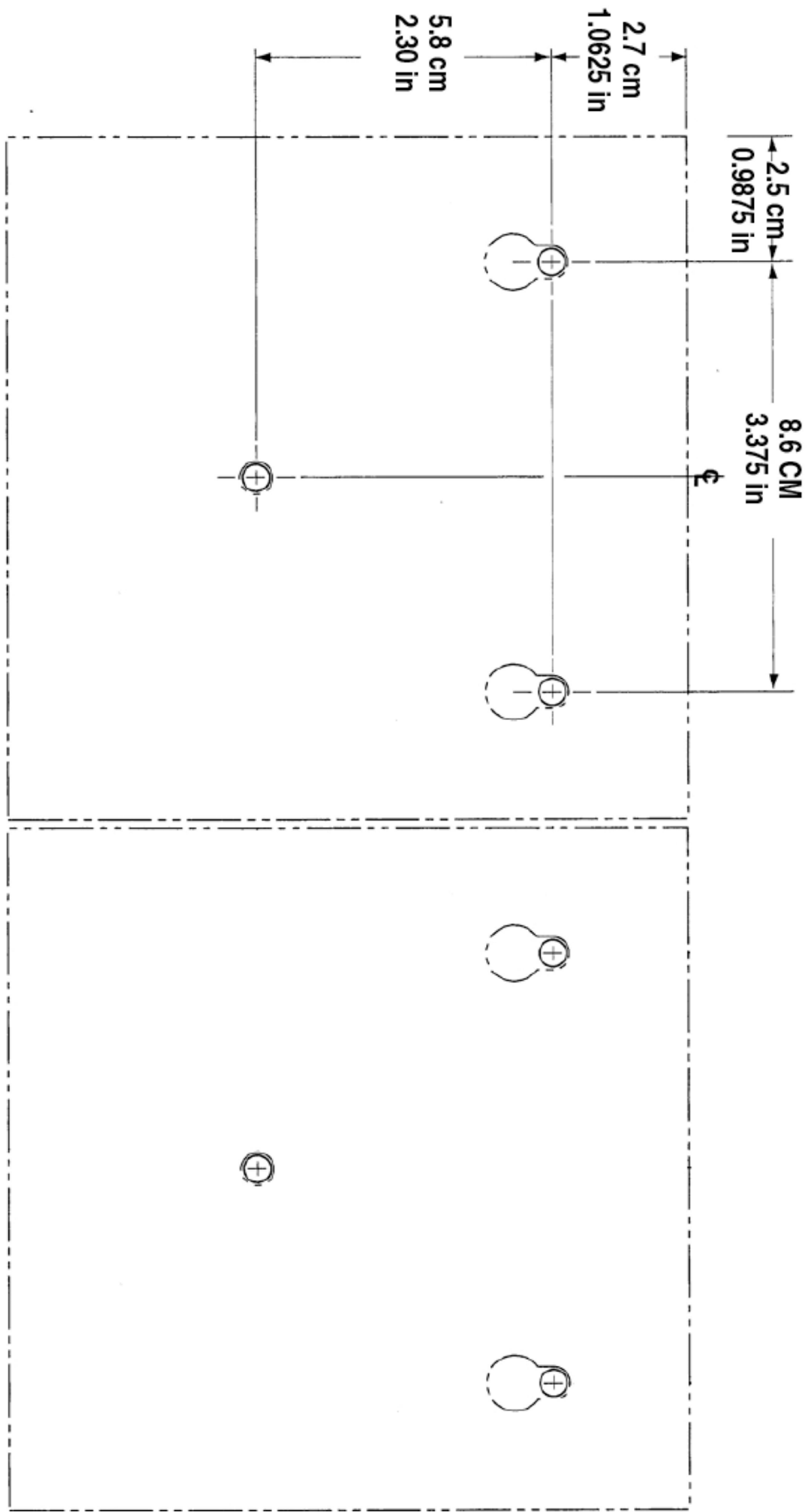

Figure 10. D3000 Mounting Template



Beta Technology
 2841 Mission Street
 Santa Cruz • CA
 U.S.A. • 95060-2142

TEL • 831 • 426 • 0882
 TEL • 800 • 858 • 2382
 FAX • 838 • 423 • 4573
 FAX • 800 • 221 • 8416
<http://www.beta-technology.com>
sales@beta-technology.com

Beta Technology is ISO 9001 Certified