

Mesa

Laundry Dosing System

Installation and Operation Manual



SAFETY NOTES

- When servicing Mesa, make sure unit is disconnected from power source and no triggers are live.
- Refer installation and service to qualified personnel only. Installation must comply with all applicable plumbing and electrical codes.
- When removing or installing Mesa pump components, wear adequate protective clothing such as gloves and safety glasses or goggles.

INTRODUCTION

This manual describes how to use the Mesa.

Material in this manual is subject to change without notice. Manual revisions will be made on an as needed basis. Special circumstances involving important design, operation or application information will be released via Equipment Technical Bulletins.

If the equipment is used in a manner not specified by Beta Technology, Inc. or Beta Europe, the protection provided by the equipment may be impaired.

© Beta Technology, Inc., Beta Europe, 2002

OVERVIEW

Mesa is a two-to-three chemical dispenser for applications such as toploading and OPL. It is not intended to pump into pressurized lines.

Sequence Mode

A “sequence” is a set of commands (“steps”) performed by the Mesa dispenser that constitute a wash cycle. The “steps” within the sequence can be pump actions, “ignores” of the drain signal until the next drain signal is received, or the “End” step, which ends the sequence.

- Mesa allows you to program up to six different sequences.
- Within each sequence, you may program up to seven steps. Each time the Mesa receives a T1 trigger signal, it is counted as a step.
- Within each step, you may program a maximum of two pump actions (“a” and “b”).
- Up to three pump actions can be programmed per sequence.
- Once the sequence has finished, there will be no further pump actions until a new sequence is started.

Sequence versus. Formula and Relay Modes

Mesa functions in Sequence Mode. It does not work in Formula or Relay modes.

Beginning a Wash Cycle

In Sequence Mode, sequences are assigned and selected by number just like formulas in Formula Mode. For example, you might use Seq 1 for sheets, Seq 2 for towels, etc. Unlike Formula Mode though, Sequence Mode requires the user to push a button (either the ACTION button on the dispenser itself, or the optional Remote Control) or send a trigger signal to begin the cycle.

Wiring

With Formula and Relay modes, a separate trigger signal is typically used to run each different pump; three pumps typically require three trigger connections. Sequence Mode wiring uses only the drain signal. Therefore, only one trigger connection is required.

Programming

Because Sequence Mode uses only one signal, *the dispenser runs pumps based on the number of times the signal is received*. When programming, the user counts the number of drain signals, and then programs the dispenser to run pumps after the drain signal has occurred a certain number of times.

For example, if the drain valve signal occurs twice prior to main wash, we’d program the dispenser to ignore the first two times it occurs, and then pump detergent and bleach the *third* time the drain signal comes on. Similarly, we’d ignore the drains for rinses in between main wash and final rinse, pumping softener on final rinse.

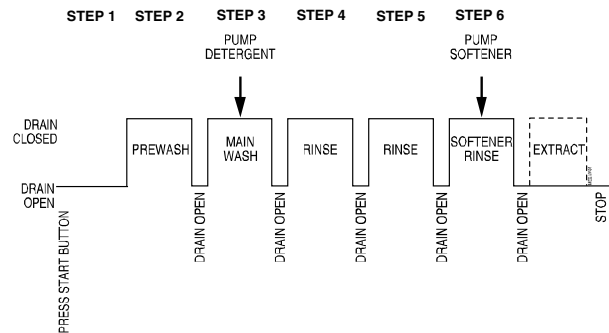

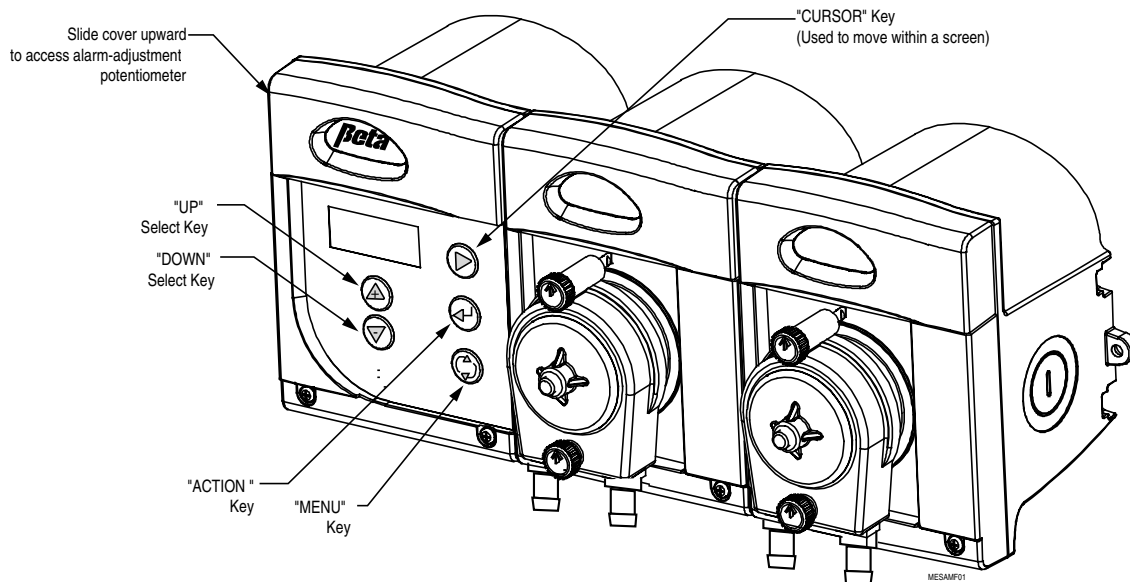

Figure 1. Mesa, Typical Two-Product System

OPERATION

All normal operation is conducted from the Run screen.

Starting a Sequence

Any of the following actions will start a sequence:

1. Pressing the ACTION key
2. Mesa receiving a high-voltage T2 trigger
3. Pressing Remote button



Mesa will ignore any trigger signals received while a pump action is being performed.

Changing Sequence Numbers

- If no sequence is running, press UP or DOWN key to change the sequence number.
- To switch from one sequence to another while a sequence is running, cancel the running sequence and press the UP or DOWN key to select the desired sequence.

Cancel Sequence

Any of the following actions will cancel a sequence:

- Pressing the ACTION key on the dispenser
- Pressing the Remote Control key for two seconds
- Priming any pump
- Disabling dosing

"End" will display on the bottom right of the screen when the sequence is cancelled.

Priming

Press the MENU key to reach the prime screen, and select the pump you want to prime with the UP/DOWN keys. Pressing the ACTION key primes the pump number displayed on the screen.

Low Product Alarm

If you have connected a low-level alarm lance to contact closure 4 (see Figure 5) and the system detects a low-chemical condition, the audible alarm turns on and the following screen is displayed:



This screen alternates with the following "ALARMOFF" screen at one-second intervals. Pressing the ACTION key will turn the alarm off. If the alarm is turned off with the ACTION key, but the chemical level is still low after five minutes, the alarm will turn back on. The alarm will not be shown while in the Level 2 Programming Screens.

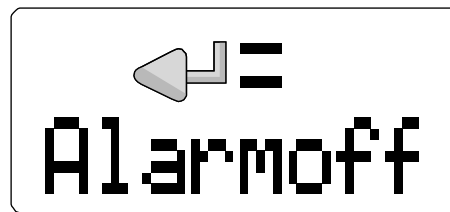

SPECIFICATIONS

PHYSICAL DIMENSIONS, CONSTRUCTION AND MOUNTING

Three-Product Enclosure

Height	Width	Depth	
5.75	15.25	5.5	Inches
14.61	40.96	13.97	Centimeters

Two-Product Enclosure

Height	Width	Depth	
5.75	11.50	5.5	Inches
14.61	31.12	13.97	Centimeters

Weight

4.38 lbs (2 kg) for 3-pump system.

Cabinet Material

ABS – Flame Retardant
IP54 Water-Resistant

Mounting

Wall mounted with stainless steel bracket or mounting tabs.

OPERATING CONDITIONS

Ambient Operating Temperature

36 to 104° Fahrenheit (2 to 40° Celsius)

Electrical Power Configurations

100-240VAC, 50-60 Hz, 0.42 Amp (max)

Fuse

Mesa has no user-serviceable fuse. Protection is provided by the power supply.

COMPONENTS

Pumps

Peristaltic, dual roller, self-priming and self-checking.

Tube

High-flow Flex, 8 oz, 230 ml per minute

Trigger Voltage Range

24VAC to 240VAC
30VDC to 100VDC

Current

0.5 mA minimum (at 24 VDC)

Sonic Low Level Alarm

Emits 80db at 4 feet (1.22 meters)

Hydraulic Performance

Maximum Vacuum 8 in (200 mm) of mercury
Maximum Pressure 1.4 bar (20 psi)

APPROVALS

CE approved
CSA

INSTALLATION & SETUP

PHYSICAL INSTALLATION

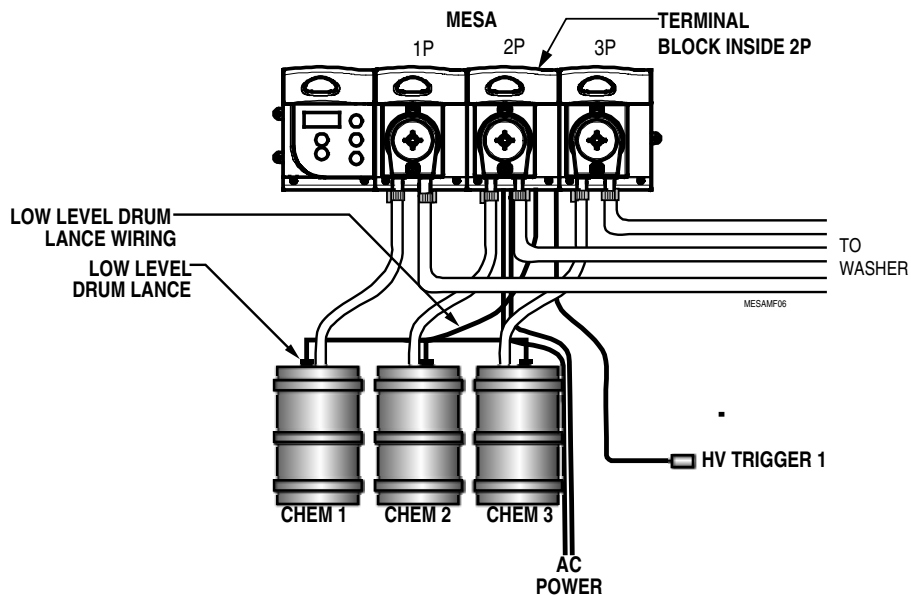

Figure 2. Typical Installation



Refer installation and service to qualified personnel only. Installation must comply with all applicable plumbing and electrical codes.

Mounting the Unit

We recommend mounting the unit with the mounting bracket rather than using the end tabs.

Avoid mounting near steam and other sources of moisture, such as from spray or splash. Do not subject the unit to temperatures outside the range 36 °F to 104 °F (2 °C to 40 °C).

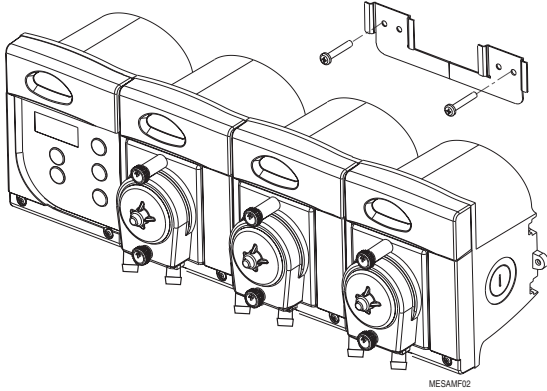

Figure 3. Mesa with Mounting Bracket

Chemical Input Lines

Connect the 1/4-inch (6 mm) line to the barb on the left (inlet side) of the pump squeeze tubes. Secure the tube onto the barb with a tie wrap or hose clamp. Make sure the connection is air tight.

1. Run the lines to the chemical drums, and secure the end of each supply line into its respective container. To ensure that chemical is properly supplied, we recommend using a standpipe or other securing device to support and hold the chemical uptake tube in place within the chemical drum. A plastic standpipe is in the **Accessories and Spare Parts** section of this manual.
2. Cut the line at a 45° angle.
3. Press the feed end of the line into the open part of the U.
4. Leave the bottom of the standpipe slightly lower than the inlet of the line.

ELECTRICAL CONNECTIONS



- Dangerous voltages may be present in the enclosure.
- Refer installation and service to qualified personnel only.
- Installation must comply with all applicable electrical codes.
- Wire size for Main Power and all high voltage connections must be a minimum of 20 AWG, rated for 600 volts.
- Suitable earth ground must be provided.

- A service disconnect must be provided for either this equipment, or the equipment to which it is attached.
- All 7/8" knockouts are intended for flexible conduit only.
- All wires should be routed through the bottom knockouts, through either strain relief or conduit.

Opening Unit for Wiring

Slide 2P (see Figure 4) cover up and gently pry off by inserting a screwdriver under the side. Remove screws from four corner of cover to open unit.

Removing Knockouts

Use a flathead screwdriver to puncture the indent in the center of the knockout, and pry/twist to remove it. Do not use excessive force as the plastic enclosure could be damaged.

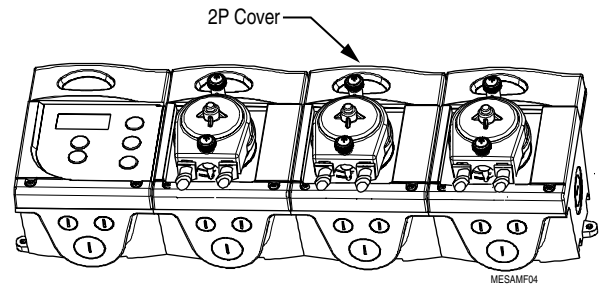

Figure 4. Mesa, Bottom View with Knockouts

A selection of plugs, strain reliefs and conduit fittings are listed in the **Accessories and Spare Parts** section.

Power and Trigger Connections (see Figure 5)

- Power:** 100-240VAC, 50-60Hz and ground
- Trigger 1:** Drain Signal, 24 VAC-240VAC or 30VDC-100VDC
- Trigger 2:** Washer ON signal for automatic start (optional), 24VAC-240VAC or 30VDC-100VDC

Low Level Alarm

Connect the low level alarm to contact closure 4 (see Figure 5); to use this feature with multiple alarm lances, connect them all to contact closure 4.

Mesa's audible alarm is in the same enclosure as the keys (see Figure 1). To adjust alarm volume, slide up the cover and turn the potentiometer counterclockwise to reduce volume, or clockwise to increase volume.

Remote Button Wiring

If you have purchased the optional Remote Control unit, snip the telephone connector off the push-button assembly, and strip the ends of the red, yellow, and black wires. Put a jumper wire into contact closure 1- & 2- (see Figure 5), and put the red wire into the contact closure 1-. Connect the black wire to contact closure 1+, and the yellow wire to contact closure 2+.

The Remote button is intended for use in two-sequence toploding applications. Pressing the Remote's "START WITHOUT BLEACH" button will switch the sequence to Seq 1 and activate it as though all triggers were turned on.

Pressing the Remote's "START WITH BLEACH" button will switch the sequence to Seq 2 and activate it as though all triggers were turned on.

An example of a two-sequence application would be pumping detergent and softener with Seq 1, with 00 runtime for bleach, and pumping detergent, bleach and softener with Seq 2. A delay would be used for the softener pump so that the chemical would be pumped during a rinse.

To cancel a signal, hold either key down for a minimum of two seconds.

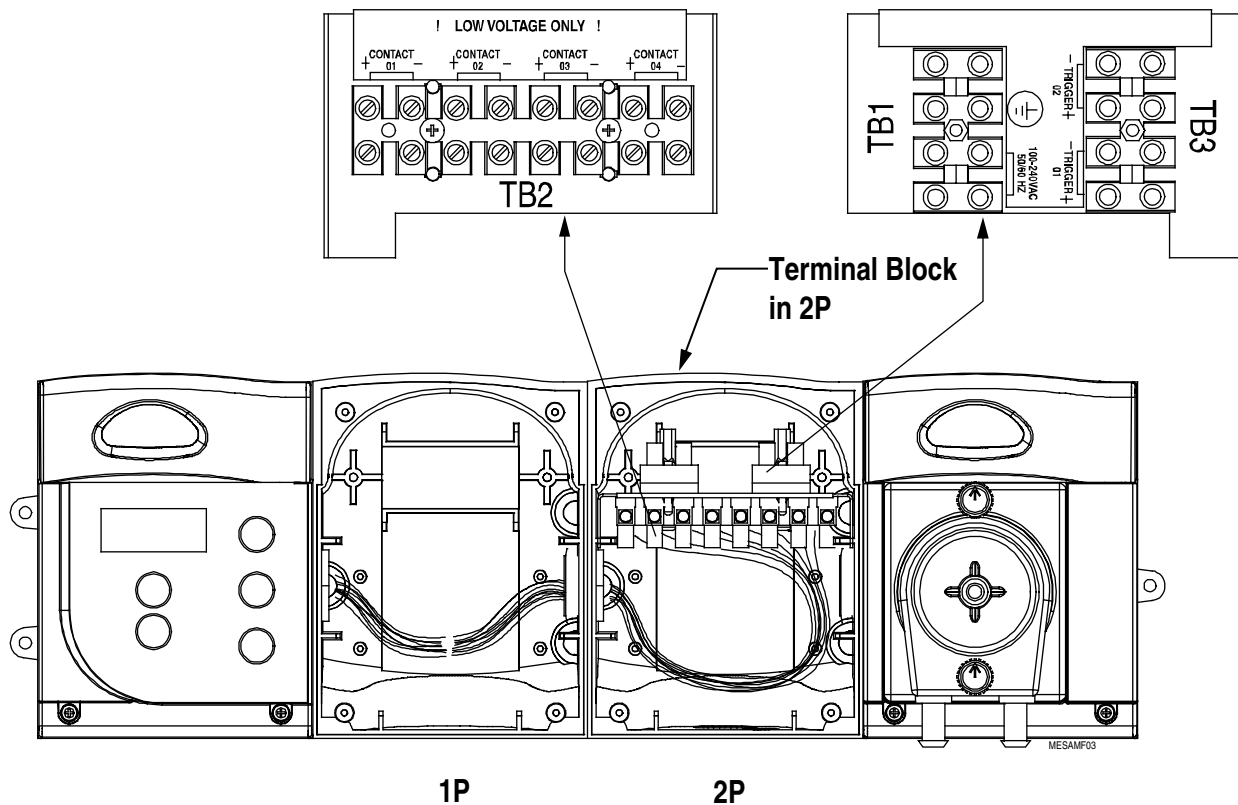

Figure 5. Mesa Wiring/Removable Terminal Block

Figure 5 shows the Mesa terminal block, which slides out so wires can be easily attached. The dispenser needs constant power supplied to the 100-240 VAC input. Trigger voltages must meet the specifications.

PROGRAMMING PROCEDURES

This section describes Mesa's keys and the different programming/status screens.

The Mesa screens have two access levels: Level 1, Laundry Worker Screens, and Level 2, Programming Screens. Level 1 screens have no access restrictions, whereas Level 2 screens require a password.

Key	Description and Function
	UP/DOWN keys, used to change the value of a variable.
	CURSOR key, for navigating with a screen/changing which digit is selected.
	ACTION key, to perform an action such as priming a pump or canceling an alarm.
	MENU key, switches from screen to screen.

Level 0: The Power Up Screen



Screen 0: Power Up Screen

When Mesa is powered up, it displays the firmware version on the screen for about a second, and then shows the Run Loop screen (Screen 1).

Level 1: Laundry Worker Screens

The Run screen allows the operator to change the sequence selection.¹

The MENU key can be pressed to cycle through the other Level 1 screens.

Run Screen

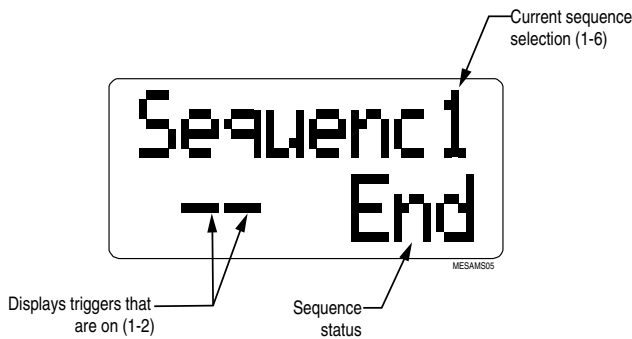

Screen 1. Run Screen

The Run screen displays the current sequence selection (1-6) on the top line. Default is “1”. The bottom line shows which triggers (1-2) are present. When no trigger is present, dashes are shown.

If a sequence has started, a pump icon will display on the bottom right of the screen. The pump icon will be displayed whether the current sequence step is an IgnoreT1 or pump action, so the operator will know that the sequence is running. When no sequence is running, “End” will display on the bottom right of the screen.

In the screen shown, no triggers are present and this sequence is not running. Refer to the **Operation** section for operational details.

Press the MENU key to go to the Prime screen.

Prime Screen

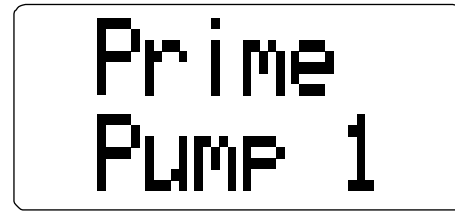

Screen 2. Prime Screen

The UP/DOWN keys change the pump number selection (default is “1”). To prime the selected pump, press the ACTION key. The pump will prime only as long as you hold the ACTION key down.

Pressing the MENU key again leads to the Dosing Enabled Screen.

Dosing Screen

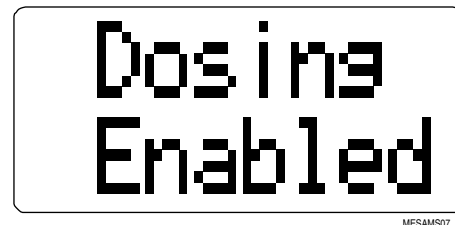

Screen 3. Dosing Screen, Enabled

Press the UP/DOWN arrow keys to toggle the screen between DOSING ENABLED or DISABLED. When you select DISABLED, pumps will not respond to triggers or to the pressing of the MENU, CURSOR or ACTION keys.

If no buttons are pressed for two minutes, the screen will change back to the Run screen, and the pumps will re-enable. Pressing MENU or ACTION while the pumps are disabled will restart the two-minute countdown.

The purpose of this screen is to allow you to turn off dosing for pump tube replacement. By default, dosing is ENABLED.

To advance to Screen 4, select ENABLED and press the MENU key.

Advance to Program Loop Screen



Screen 4. Advance to Program Loop Screen

This screen allows you to either advance to the Program Loop, or to go back to the Run Loop Screen. The UP/DOWN arrow keys toggle between “YES” and “NO”. Selecting “YES” and pressing the MENU key advances to the Password Screen.

¹ Any screen reverts back to this screen if the unit stands idle for 2 minutes.

Leaving “NO” selected and pressing the MENU key takes you back to the Run Loop Screen.

Password Screen

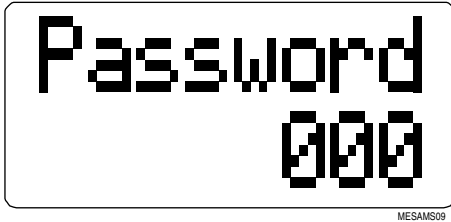

Screen 4. Password Screen

Enter the password using the UP/DOWN keys to select the numbers, and the CURSOR key to navigate between the three digits. The default password is “000”.

Press the MENU key to advance to the next screen; if an incorrect password is entered, an error message will display for three seconds.

Level 2: Programming Screens

NOTE  Pumps will not run while Level 2 screens are displayed. Entering Level 2 screens cancels any sequence that is running.

After entering the correct password from Screen 4, you will advance to the first programming screen, Sequence Setup.

“End” is the default setting for each step. You can change the setting by using the CURSOR key to select the bottom line, and the UP/DOWN keys to change the bottom line selection for the sequence step shown on the top line.

For each load class (whites, colors, mops, etc.) you will program a different sequence. For each sequence, count the number of drain signals received, noting which signals are for pre-wash, main wash and final rinse.

The sequence is a set of steps. Step 1 (S1) is performed when the sequence starts. Step 2 (S2) is performed on the first receipt of the drain valve trigger. Step 3 (S3) is performed on the second receipt of the drain valve trigger.

For a load class such as sheets, where the second drain signal comes from the valve closing for the main wash, and the fifth drain signal is final rinse, you would change the bottom line for S1 and S2 to “IgnoreT1”, S3 to a pump action of P1 detergent and P2 bleach for main wash, S4 and S5 to “IgnoreT1”, and S6 to a pump action of P3 softener.

For a load class such as mops, you may pump detergent for pre-wash, and detergent and bleach on the main wash.

Sequence Setup Screen, Pump Actions

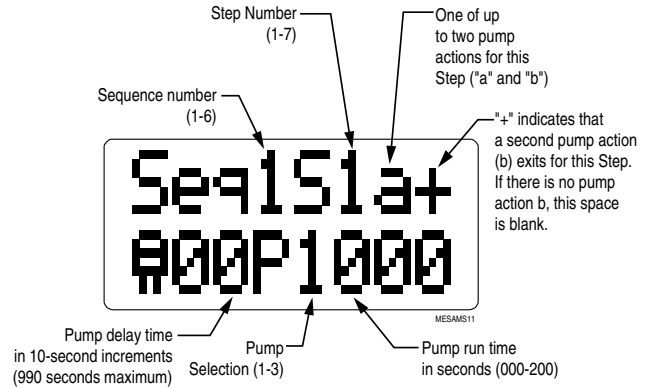

Screen 5. Sequence Setup, Pump Actions

The Sequence Setup screen allows you to program each of your sequences, sequence steps, pump actions, and pump run and delay times. Screen 5 shows the screen used for programming pump actions. You may program a maximum of two different pump actions per step (“a” and “b”). A “+” sign next to the pump action “a” indicates that a second pump action (“b”) exists for that trigger. This allows you to run two pumps simultaneously for one occurrence of T1.

Default values are shown on the Screen 5 graphic. The pump selection is variable to as many pumps as you have installed (up to three).

You may program a maximum of three pump actions per sequence. Once three pump actions have been programmed for a sequence, only “IgnoreT1” and “End” can be programmed for subsequent steps. “End” is the default.

Sequence Setup Screen, “IgnoreT1”

To program the Mesa to ignore a trigger signal, select the sequence and step for which you want the T1 signal ignored, then CURSOR down to the bottom line. Press the DOWN key, and the selection changes from pump action programming to “IgnoreT1”.

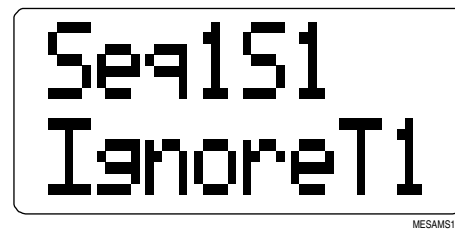

Screen 6. Sequence Setup, Ignore T1

In this example, step 1 of sequence 1 has been programmed to ignore the occurrence of T1, and the next step (S2) will be performed the next time the T1 signal is received.

Press the UP key to return to pump actions, or the DOWN key to go to the “End” step.

Sequence Setup, “End”

To program the “End” step to a sequence, select the sequence for which you will program the step, and the number of the step within that sequence that will be the “End” step. Press the DOWN key and the selection changes to “End”.

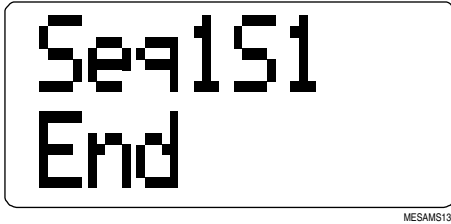

Screen 7. Sequence Setup, "End"

When the trigger prior to the "End" sequence step is received, "End" is displayed on the bottom line. No further steps will occur after the "End" step, until a new sequence is started by one of the following actions:

- Pressing the ACTION key
- Mesa receiving a high-voltage T2 trigger
- Mesa receiving a low-voltage contact closure 1 or 2 signal

Press the UP key to return to "IgnoreT1", or the DOWN key to return to pump actions.



Any sequence will automatically end once step 7 is completed, even if an "End" step has not been programmed.

If no "End" step is programmed, and T1 does not occur more than 5 times, the sequence will never end, and will have to be cancelled by holding down the ACTION key for five seconds, or entering the Level 2 screens.

Change Password

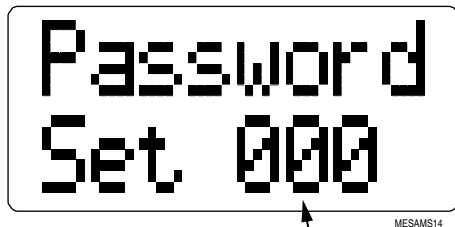

Programmer-Level (Level 2)
Access password (000-999)

Screen 8. Changing Password

While the dispenser ships with "000" as the default password, Screen 8 allows you to change it for increased security. Use the UP/DOWN keys to change the each digit, and the CURSOR key to navigate through the three digits.

Trigger Voltage

Use Screen 9 to select whether T1 activation will be based on rising or falling voltage. "Rising" voltage ("+"), means that activation occurs when voltage turns on, and "falling" voltage ("-"), means that activation occurs when voltage turns off.

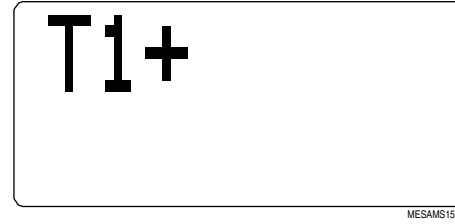

Screen 9. Trigger Voltage Screen

Most washer drain valves' voltage is on when it is closed, so you will not usually need to change T1 to "-".

Trigger 2, for automatic sequence start, is always a rising trigger.

Pressing the MENU key from Screen 9 advances you to the Load Count screen.

Load Count Screen

This screen shows how many times the sequence number displayed has run. Each time a sequence reaches its "End" or is cancelled, the counter goes up by one digit. It continues counting the sequence each time it runs to completion, until it reaches 999, at which point it reverts back to 000.

Pressing the UP/DOWN arrow keys changes the sequence number. The load count can be reset to 000 by pressing the ACTION key for two seconds.

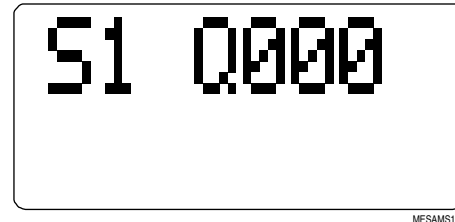

Screen 10. Load Count Screen

Exit Screen

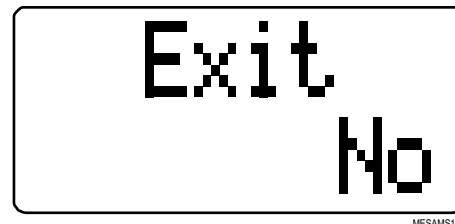

Screen 11. Exit Screen

This screen is used to exit the Level 2 Programming Screens back to the Level 1 Sequence Select Screen.

Changing the "NO" to a "YES" using the UP/DOWN keys, and pressing the MENU key will exit back to Level 1 (Run Screen). Pressing the MENU key while the "NO" is displayed will return back to the Sequence Setup Screen.

MAINTENANCE



TURN OFF all power before servicing.

Servicing Interior Components

To access interior, slide top cover up and gently pry off. It may be necessary to pry the cover off with a flat-head screwdriver. If this is necessary, take care not to damage the unit. Then remove the four screws.

Pump & Squeeze Tube Replacement Schedule

Since every installation is different (chemicals, tube runs, operating frequency, etc), an exact tube replacement schedule cannot be specified. With use, the tube slowly evolves from round to oval and the amount of chemical pumped decreases. By regularly checking the amount of chemical pumped, you can determine general tube life. We recommend that you closely monitor the time it takes the original tube to reach the end of its flex life, and then establish a replacement schedule. Replacing tubes at regularly scheduled intervals ensures more accurate product use and reduces service calls. In general, using short feed lines of a large diameter will improve pump tube life.



It is very important not to let the tubes become worn to the point where they tear and allow chemicals to saturate the pump housing.

How to Replace Pump Cartridges and Squeeze Tubes

Only the cartridge replacement should be done in the field. Tube replacement can be accomplished later. Note that each product has different delivery line configurations and squeeze tubes. Refer to the **Specifications** for tubing materials.

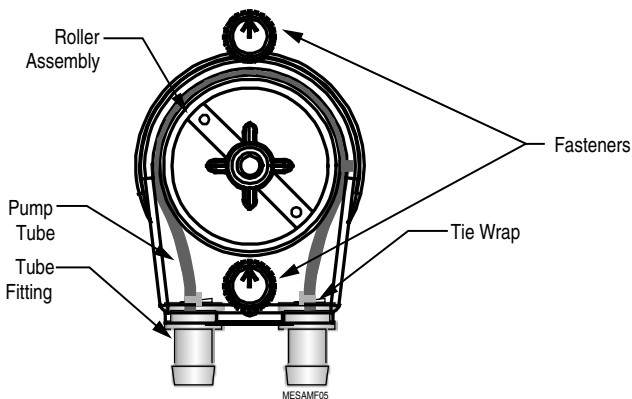

Figure 6. SnapHead Pump

To Remove

1. Disable unit, or turn off main power.
2. Remove the cartridge from the motor housing by twisting the two quarter turn fasteners at top and bottom counterclockwise while gently pressing.



Wear adequate protective clothing such as gloves and safety goggles.

3. Remove the supply and feed lines from the old pump squeeze tubing and connect them to the new pump squeeze tubing.

To Install

1. Disable unit, or turn off main power.
2. Align and engage the pump drive spline with the motor gear.
3. Turn the fasteners so that arrows are pointing upward.
4. Hold the cartridge vertically and press the fasteners into the motor housing until you hear a distinct click.



It is very important that the tabs are vertical and that you press them firmly enough to hear them click. Incorrect installation could damage the pump

How to Change the Pump Squeeze Tubing

1. Remove the cartridge as described above.
2. Remove the small screw at the bottom of the rear cover and lift the cover from the cartridge.
3. Pull the adapter fittings rearward until they clear the cartridge.
4. Pull the roller assembly rearward to release the pump squeeze tubing.
5. Cut the tie wraps holding the pump squeeze tubing to the adapter fitting and pull the tubing from the fittings.
6. Replace the pump squeeze tubing making certain to use the proper size tube.
7. Push the adapters on to the ends of the tubing and secure with tie wraps. Make certain that the "buckles" of the tie wraps are both facing the same direction. This will keep the tube from twisting in the cartridge.
8. When using B-Flex tubing, coat the inside of the cartridge with a liberal amount of Silicone 111 lubricant.
9. Press the 2 adapter fittings into the cartridge so that the tie wrap "buckles" face toward the center of the pump.
10. Push the roller assembly onto the cartridge shaft using a twisting motion to engage the rollers properly with the pump squeeze tubing.
11. Return the rear cover and secure with the small screw at the bottom. The flat side of the cover should face inward.

How To Replace Pump Motor Subassemblies

To Remove

1. Ensure power and all triggers are off/disabled.
2. Remove the pump cartridge from the motor assembly, leaving the chemical lines attached. Remove front cover.
3. Remove the electrical connections at the back of the motor.
4. Compress the two flex ears on the back of the motor until the motor slides out through the hole in the cabinet.

5. For detailed information on Mesa subassembly structure, please see **Appendix B**.

To Replace

1. Ensure power and all triggers are off/disabled.
2. Locate the alignment tip of the pump motor housing so it is in the down position.
3. Slide the pump motor housing into the enclosure hole. The holding ears will expand to hold the pump motor/solenoid in place. Verify that both ears popped out and are locked in place.
4. Reinstall the electrical connections at the back of the motor (Refer to **Appendix B** for wiring diagram).
5. Install the pump cartridge.
6. Prime the pump to verify proper pump rotation (clockwise). If the direction is wrong, switch the motor wires.

TROUBLESHOOTING

Refer to the assembly drawings and the complete unit wiring diagram in the **Appendix B**. To order replacement spares, see **Accessories and Spare Parts**. Please order using the item number.

No Power



The following procedure is to be performed only by qualified personnel.

Check the following:

1. Check power supply terminal strip connection (TB1-1,2) and verify that there is appropriate line voltage.
 - a) If there isn't appropriate line voltage, check wiring and power supply.
 - b) If there is appropriate line voltage, proceed to Step 2.
2. Confirm connection CN1 is firmly seated on the power supply board. If firmly connected and the Mesa is still not functioning remove CN1 and confirm that appropriate line voltage (100-240VAC) is present on the input wire.

If there isn't appropriate line voltage is present, check wiring between CN1 and TB1. If there is appropriate line voltage, proceed to Step 3.
3. Reconnect CN1. Disconnect J2. Confirm that appropriate input voltage (24VDC) is present.
 - a) If there isn't appropriate line voltage, replace Mesa power supply PCB.
 - b) If there is appropriate line voltage, replace Mesa controller PCB.

Chemical Feeds Too Often/Too Much Chemical Used

Check the chemical control setup and harness. (Refer to the original setup records.) If wrong, correct. If OK, replace the PCB.

Chemical Does Not Feed at All (Pump Doesn't Turn)

1. Check Run screen to see if pump icon is displayed, indicating that the sequence is running. If pump icon is not displayed, press the ACTION key. If pump icon does not appear, change step 1 to "IgnoreT1" or to a pump action.
2. Verify that pump times are entered for the correct steps (occurrences of T1). If no pump times are entered, enter them.
3. If pump times are entered, check Run screen to verify T1 is being received when drain closes.
4. If drain valve voltage turns off when valve closes, change Trigger Voltage (Screen 9) to "T1-".
5. If drain valve voltage is turning on, but trigger is not being received, replace trigger wire.
6. Use voltmeter to verify 24 VDC is present on pump driver wires while priming. If 24 VDC is present, replace pump motor. If 24 VDC is not present, disconnect harness and test at PCB output. If 24 VDC is not present at PCB output, replace PCB; if present, replace harness.

Pumps Turn on Too Late

1. Verify that drain valve voltage is turning on when drain is closed. If drain valve voltage is off when valve is closed, and on when it is open, change Trigger Voltage (Screen 9) from "T+" to "T1-".
2. Check pump action steps in the Sequence Setup screen (Screen 5) to be sure that delays have not been incorrectly entered. Note that a delay of "30" is 300 seconds, not 30 seconds.

Chemical Pump Feeds Continuously

Check the run time of the pump and the operation of the prime key. If the pump continues to run beyond that run time, check the wiring harness. If pump still feeds continuously, replace the Mesa Main PCB.

Pump Will Not Pull the Chemical Out of the Drum

1. Too much vacuum created. The supply line in the chemical drum may be up against either the side or bottom, the supply lines may be too long for a viscous product, or there may be a crimp in the intake supply line, thus exceeding the pump's vacuum specifications.
2. There may be an air leak somewhere in the input supply line. Most often this is caused by inadequate sealing of the supply line. See **Installation and Setup** section for recommended procedure.
3. Squeeze tube is worn and the rollers can no longer squeeze the tube properly. Correct by changing the pump cartridge with the correct size squeeze tube and line nuts for the chemical being pumped.

ACCESSORIES & SPARES

The items listed in this section provide you with quick reference numbers for some of the major parts and accessories. A complete exploded assembly drawing is located in the back of the manual. Please note that transport tubing, power/trigger wires and cable glands/strain reliefs are sold separately from the Mesa.

Main Components

Mesa, 3 pump, 3/8" (10 mm)B	1201161
Mesa, 2 pump, 3/8" (10 mm)B	1201162

Spare Parts and Accessories

1/2" Strain Relief, Small Knockout, Nylon	032121
3/4" Strain Relief, Large Knockout, Nylon	090369
Low Level Alarm Lance	091518
Remote Buttons	1201630
Panel mount low level alarm, 100 dB	1200452
Mounting Bracket	069188
Power Supply PCB 100-240 VAC	087751
Main PCB	1201169
1/2" Watertight Plastic Conduit Elbow	068529
1/2" Plug	041236
*Pump cartridge, EPDM2/Nordel, 1/4" T	058769
Tube kit, High Flow Flex, 3/8" (10 mm)B	069858
*Pump cartridge, Viton, 1/4" T	069927
Insert, rinse, outlet, 1/8"	036982
Motor Gearbox	051351
Chemical Tubing Standpipe	036857

*High-flow Flex uses a different roller than other tubing. If changing to a tube other than Flex, buy a complete pump cartridge to ensure that you have the correct roller.

TECHNICAL ASSISTANCE

If you require additional technical information, contact our Technical Support Department at 1-800-468-4893. From Europe, please call 0800-052-4726.

RETURNING EQUIPMENT FOR REPAIR

If you need to send an item back to be repaired, please call or write to obtain a Returned Authorization (R.A.) Number before sending it back. Please write the R.A. # on the outside of the box before sending it back. It is also very helpful to our repair department if you include a note inside the box explaining the nature of the problem. Failure to obtain an Return Authorization Number before sending an item in for repair or replacement may delay the return of your equipment, and will incur a \$25 handling fee.

APPENDIX B: ASSEMBLY DRAWINGS

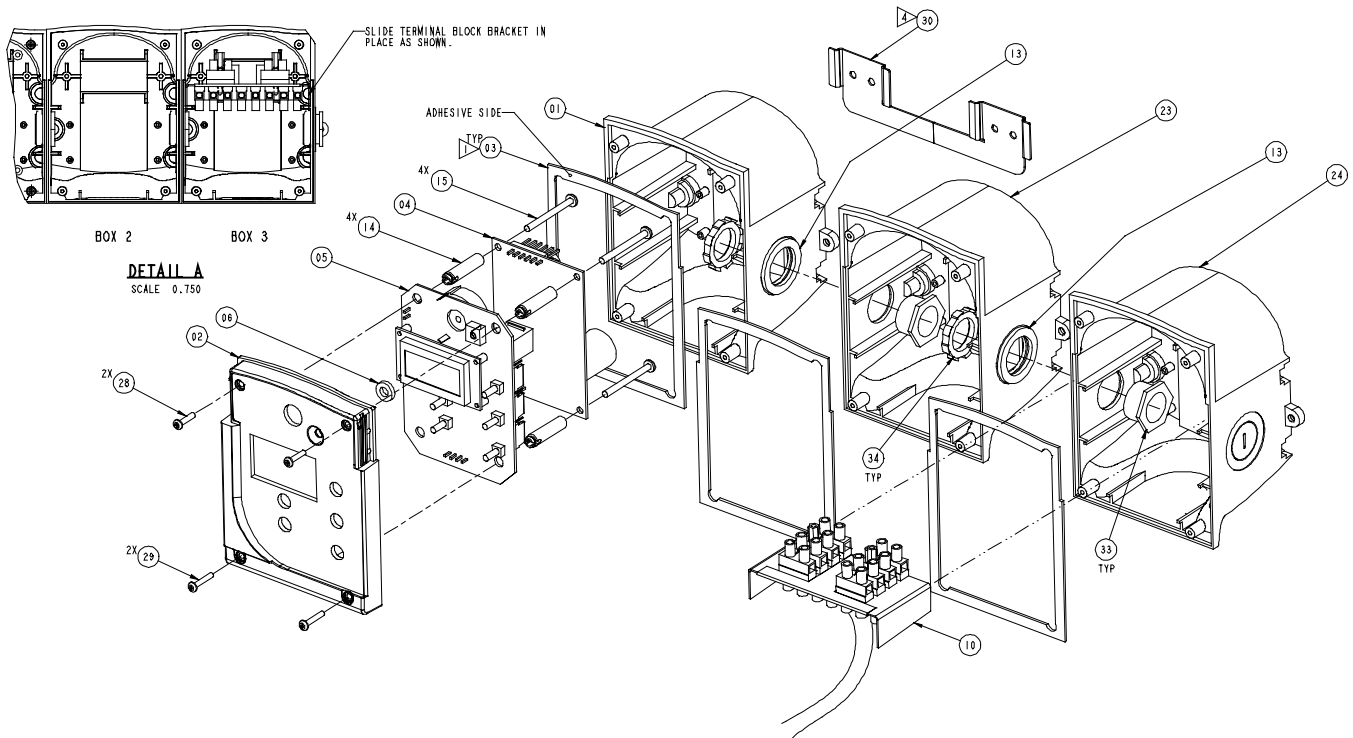

Seq #	Description	Code#	Seq #	Description	Code#
01	ENCL, BUCKET, HOLE B, GRY	1200398	13	WSHR, FL, 1.25ODX.88IDX.13, NRPN	069180
02	ENCL, BEZEL, CONT, MESA, GRY	069974	14	SPCR, SNP, 9/32RND, #6X1, NYL	069135
03	GSKT, ENCL, ADH	069630	15	SCR, T-B, PH PNH, #6X1-1/2, ZP STL	068516
04	PCB ASSY, PWR SPLY, 90-264VAC,	087751	23	ENCL, BUCKET, HOLE AB, GRY	1200397
05	PCB ASSY, MESA	1201065	28	SCR, T-B, PH PNH, #4X1/2, SST	099688
06	GSKT, LED, NPRN, PSA	087415	29	SCR, T-B, PH PNH, #4X5/8, SST, BLK	099689
10	HARN, PWR/IO, MESA, CSA	069653	30	BRKT, MTG, MESA	069188
			33	CFTG, NIP, CHASE, 1/2\", STL	069665
			34	NUT, LK, 1/2, CND	041077

APPENDIX B: ASSEMBLY DRAWINGS

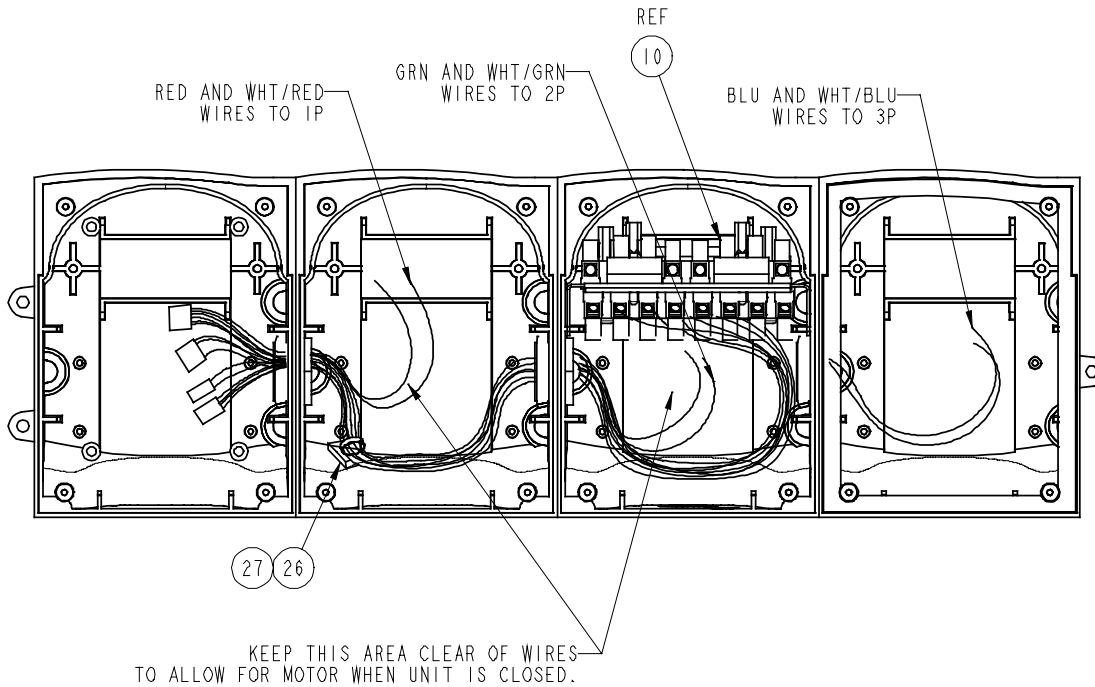

WIRE ROUTING

SCALE 0.750

Seq #	Description	Code#
0010	HARN,PWR/IO,MESA,CSA	069653
0012	HARN,24VDC,MESA	087974
0026	TIWRP,AHR,ADH,RB,3/4", NYL,NAT	041323
0027	TIWRP,.10X4L,NYL,NAT	041318
0050	CAP,MOT,1.06IDX1.60LX.06 TH	068648
0052	ENCL,DOOR,ABS,GRY	087659

APPENDIX B: ASSEMBLY DRAWINGS

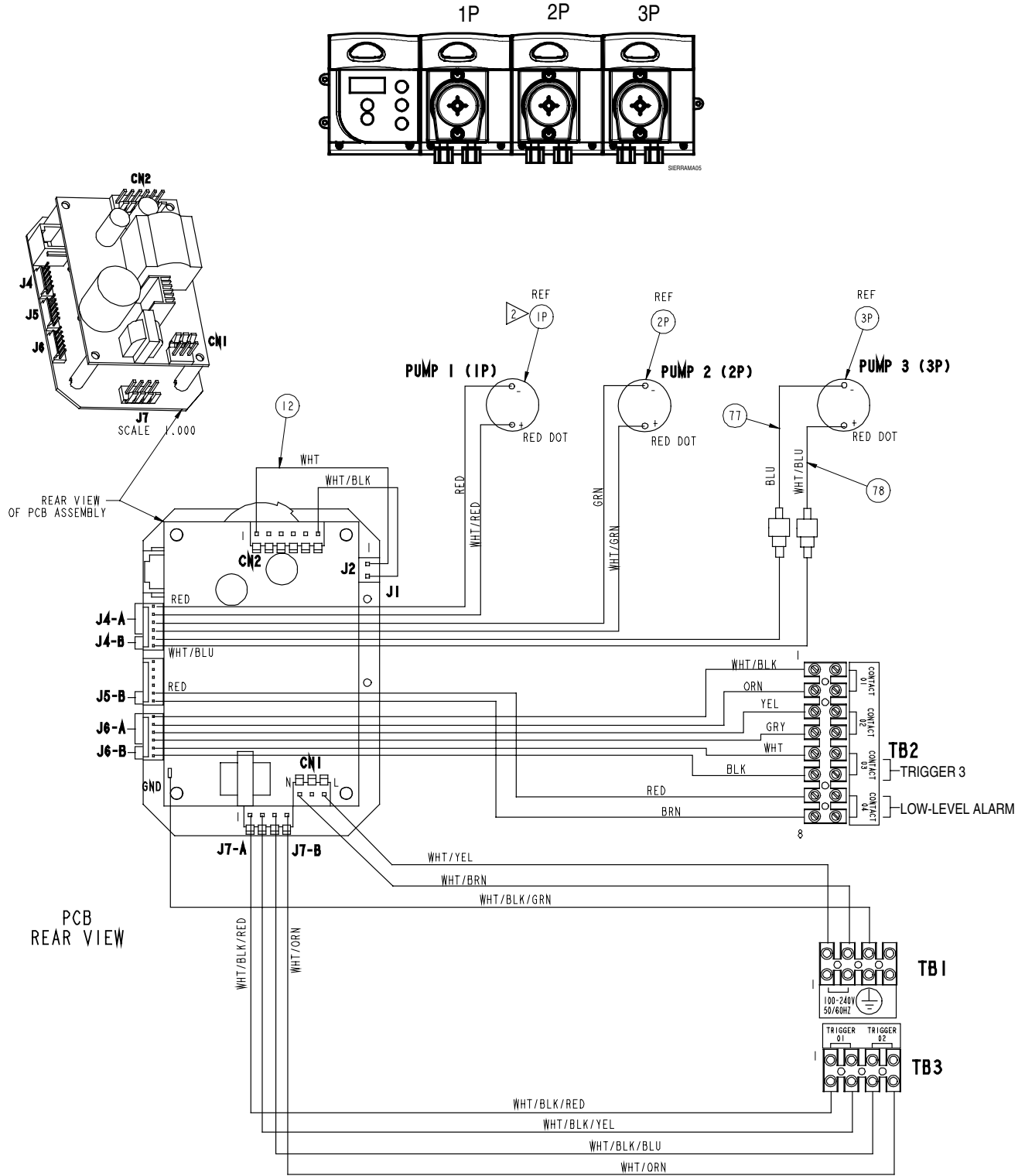

Beta Technology, Inc
 2841 Mission Street
 Santa Cruz • CA
 U.S.A. • 95060
 TEL (U.S. and Canada) • 800 • 468 • 4893
 TEL (outside U.S. and Canada) • 410 • 228 • 1292
 sales@betatechnology.com

Beta Technology, Inc
 4 Firnway, Dulliflow Road
 Luton LU1 1TR
 United Kingdom
 Customer Service
 Tech Support
 Online Ordering: <http://www.beta-technology.com>

FreePhone • 0800 • 052 • 4726
 Tel • +44(0) • 1582 • 528600
 Fax • +44(0) • 1582 • 528111
 FreePhone • 0800 • 052 • 4726
 VAT REG.NO.B5.354-09975-44
 europe.sales@betatechnology.com

Beta Technology is ISO9001 Certified