

# Newsline

Volume 18, February 2008

## Start 2008 with a Rack of Sparkling Clean Dishes!



## Beta Introduces NS3000—The Reliable, Quick-to-Install Dispenser!

Fast and easy installation, increased profits and cleaner dishes—what more could you ask from a warewash dispenser? How about versatility? Reduced maintenance costs? NS3000 gives you all of this. Here is how:

For further information please call customer service at (831) 426-0882, or fax to (800) 221-8416 within the U.S., or (01) (831) 423-4573 from outside the U.S.

# Introducing NS3000 (continued)



NS3000 Dispenser with Uniview

## Faster, Easier Installation

- NS3000 has an external transformer. This allows you to do most installations without conduit, sparing you the cost of conduit (around \$10-\$20) and the cost of installing the conduit (anywhere from \$20 to \$100).
- External-transformer construction makes the NS3000 lighter than common metal dispensers with internal transformers. This makes for a quicker, easier installation.

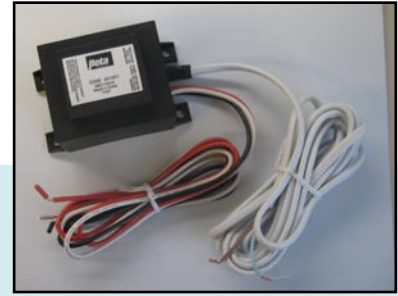

NS3000's external transformer allows for installation without conduit.

## Cost Savings with Reduced Maintenance

- NS3000 is equipped with Virtual Clean Probe (VCP™), a patented digital signal-processing algorithm that corrects for probe fouling. This greatly reduces wasted chemical due to overdosing, and the trouble calls that naturally follow. This also increases customer satisfaction!



Digital programming can be done on the Uniview programmer.

- NS3000 is also equipped with long-life tubing, so you will spend less money on tubing over the life of the installation.

## Cleaner Dishes

- Beta's famous long-life rinse tube resists the effects of wear, which ensures spotless glassware.
- NS3000's learning algorithm adjusts feeds to changing conditions, ensuring clean dishes the "green" way—without chemical waste!

## Increased Profits

- Rack count for activity based billing accounts allows you to accurately track usage and pinpoint any chemical theft.
- Spares from other NS-Series dispensers are compatibility with NS3000, so you can upgrade with minimal cost.
- Overall reduction in installation and carrying costs, maintenance costs, down-time, and increase in cleaning effectiveness boost profitability for everyone. See chart below!

## Flexibility and Versatility

- NS3000 has a modular design, so the same base units can be quickly converted from a 2-product to a 3-product system, or from all liquid to solid/powder detergent.
- Adaptable to both distributor and fully-trained sales channels; it allows for simple programming with potentiometers or more advanced digital programming with the handheld Uniview programmer.

Why not order a system today, and let the system prove itself to you? Contact Customer Service at (831) 426-0882 to order NS3000!

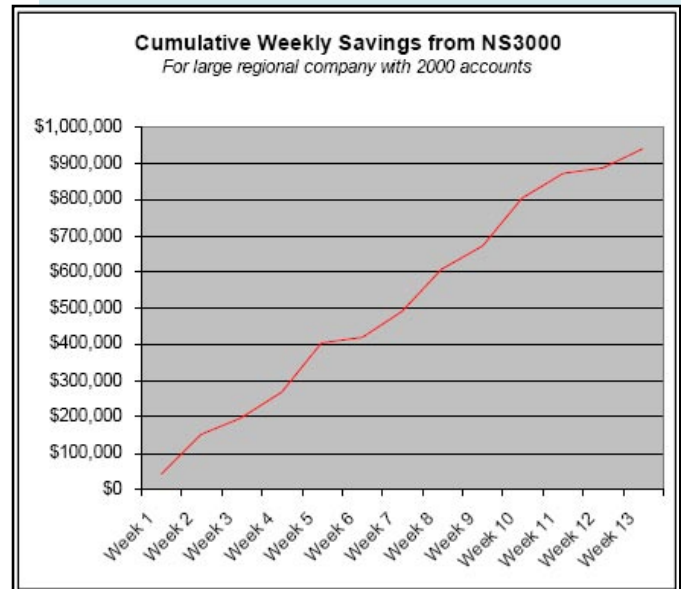

# They Asked for It, Beta Built it!

Congratulations to Beta's product development team for exemplary work on its latest collaborative effort: The Gurtler Grip V-B.

Gurtler Industries, a leading player in the laundry chemical market, has widely used the ILS product line over the years. Recently, Gurtler challenged us to develop a dispensing system that uses 1/4" Wilden air pumps within the ILS platform with auto calibration. Working closely with Gurtler, Beta not only met this challenge, but created a whole floor stand assembly.

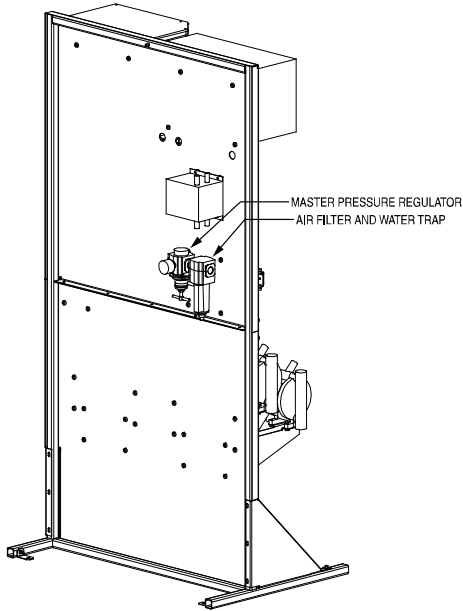

*Grip V-B System, back side*

We expect to be collaborating with Gurtler more over the coming year. Says a Gurtler representative:

"Beta Technology is the first Gurtler dispenser vendor that has stepped up and actually followed through with their promise to work with us in developing products we want. We will be moving toward using more of their products so all feedback from field people is essential and will be presented to Beta as we move forward."

Congratulations to both Beta and Gurtler for an excellent joint venture!

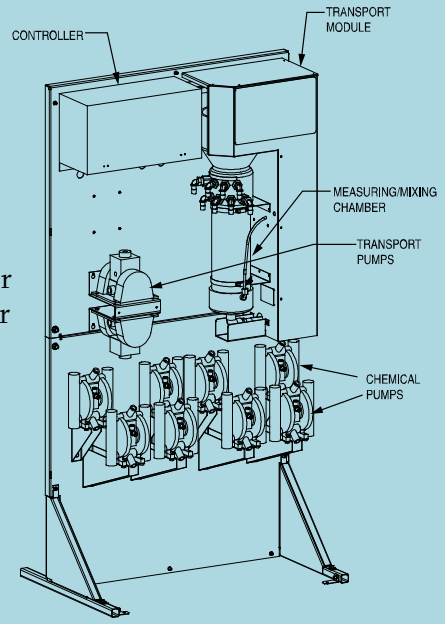

*Grip V-B System, front side*

## Who WAS that Masked Woman?

ISSA 2007 was a smashing success for Beta this year, with the introduction of NS3000, along with our recent foray into the dustmop industry, DuoClean.

The DuoClean is a combination dust mop, broom and dust bin system that revolutionizes floor cleaning. Its time and energy-saving all-in-one design is easy to see just by looking at it. Needless to say, customers and competitors alike were impressed with the system, but who was that DuoClean-wielding masked woman greeting guests, walking the show floor and signing autographs?

That would be none other than our very own superhero, the DuoClean Woman. What is her mission? To spread the word about DuoClean's superior cleaning ability, and demonstrate how it makes floor cleaning so much easier than ever. The DuoClean woman demonstrated how disposable micro-fiber cloths pick up unbelievable amounts of dirt, with such little effort that you can be done in no time. "I was just an ordinary janitor before I discovered DuoClean. Now I'm a floor cleaning superhero!" proclaimed the DuoClean Woman in a recent interview.

Interested in turning yourself or anyone you know into a floor-cleaning superhero? Contact Customer Service at (831) 426-0882 for more information about the DuoClean system.





## Now Shipping: New Summit E/XL Firmware!

Effective February 1, 2008, Summit E and XL will be shipping with new firmware, offering even better efficiency, accuracy and traceability. Among many other improvements, this new firmware will correct the problem of erroneous flush manifold no-flow errors. Look for an email announcement in February about this upgrade, along with information on how you can upgrade your current systems.

**Beta Technology**  
**2841 Mission Street**  
**Santa Cruz CA, 95060**

PRSRF STD  
U.S. POSTAGE  
**PAID**  
Los Angeles, CA  
PERMIT #33

For further information  
please call customer service  
at  
(831) 426-0882,  
or fax this to  
(800) 221-8416 within the  
U.S., or  
(01) (831) 423-4573

[www.beta-technology.com](http://www.beta-technology.com)