

NS-1000 SERIES

WAR EWASHING DISPENSER

INSTALLATION AND OPERATING MANUAL



CONTENTS

- INTRODUCTION & EQUIPMENT DESCRIPTION
 - Application Description 1
 - NS-1000 Standard Control Features 1
 - Terms 1
- SPECIFICATIONS
 - Physical Dimensions, Construction & Mounting 3
 - Operating Conditions 3
 - Components 3
- INSTALLATION & SETUP PROCEDURES
 - Physical Installation 5
 - Electrical Connections 8
 - External Controls Descriptions 9
 - Internal Controls Description 10
 - Setup Procedures 12
 - Detergent System with Probe 12
 - Detergent System Probeless 13
 - Sanitizer System 15
 - Operation 16
- MAINTENANCE
 - 1. Periodic Maintenance 17
 - 2. Troubleshooting 19
 - Recommended Spare Parts & Accessories 23
 - Warranty Information 24
 - Technical Assistance 24
 - Returning Equipment For Repair 24
- APPENDIX
 - A Dishmachines with Internal Calorifiers (Boilers) 25
 - B Typical Installation Examples 26
 - C Diagrams & Drawings 27
 - Sequence to Item Number List 27
 - NS-1000 Final Assembly 29
 - NS-1000 Wiring Diagram 31
 - Solenoid Valve Assembly 32
 - NS-1000 Pump Assembly 33

INTRODUCTION & EQUIPMENT DESCRIPTION

APPLICATION DESCRIPTION

The NS-1000 satisfies a wide range of recirculating, and fill & dump machines. Six models provide probe-controlled or probeless chemical delivery for two or three products—liquid, powder or solid detergent, liquid rinse aid and liquid sanitizer.

Warewashing machine types covered include:

- Single rack door machines
- Low volume conveyor machines
- Both high & low temperature machines

The following NS-1000 table lists the features and configurations available.

NS-1000 STANDARD CONTROL FEATURES

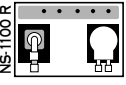
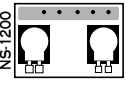
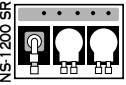
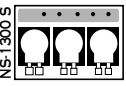
MODEL NUMBERS	DETERGENT		RINSE	SAN-ITIZER	TRANS-FORMER	DETERGENT CONTROL / ALARMS					RINSE & SANITIZER CONTROL				
	PUMP	SOLENOID	PUMP	PUMP		PROBELESS		PROBE			CONTROL				
						ADJ. RECHARGE	MAN. & AUTO INT. CHG.	ADJ. SETPOINT	ADJ. VOLUME	OVERFEED STOP SELECT	ADJ. FEED RATE	ADJ. FEED DELAY	FIXED FEED STOP	PRIME SWITCH	
NS-1100 R 	-	1	1	-	1 or 2	STD	STD	STD	STD	STD	STD	STD	STD	STD	STD
NS-1200 	1	-	1	-	1 or 2	STD	STD	STD	STD	STD	STD	STD	STD	STD	STD
NS-1200 SR 	-	1	1	1	1 or 2	STD	STD	STD	STD	STD	STD	STD	STD	STD	STD
NS-1300 S 	1	-	1	1	1 or 2	STD	STD	STD	STD	STD	STD	STD	STD	STD	STD

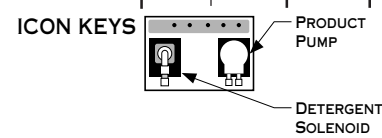

Standard with all models: On/Off Switch; Prime Switch(es).

Optional with appropriate models: Pressure Switch (only one transformer installed with this switch).

TERMS

Line

Polyflow or other plastic tubing that carries chemical supply from the source to the pump or from the pump to the washer.

Tube & Squeeze Tube

Tubing installed and designed to be used in peristaltic pumps.

Pipe

Metal or plastic rigid pipes, plumbing.

SPECIFICATIONS

PHYSICAL DIMENSIONS, CONSTRUCTION & MOUNTING

Size

5 1/2" H x 8"W x 5 5/8" D
(14 cm x 20.3 cm x 14.3 cm)

Weight

NS-1100 R-----	5.7 lb.	(2.60 kg)
NS-1200 -----	5.5 lb.	(2.50 kg)
NS-1200 SR -----	5.8 lb.	(2.65 kg)
NS-1300 S-----	5.6 lb.	(2.55 kg)

CABINET

Type 304 Stainless Steel

MOUNTING

Wall mounted with two (2) keyhole slots in the backplate.

OPERATING CONDITIONS

Ambient Operating Temperature

+36 to +120 degrees Fahrenheit
(+2 to +49 degrees Celsius)

Electrical Power Configurations

100 to 120 Volts AC, 50/60 Hz, 0.50 Amperes maximum.
200 to 240 Volts AC, 50/60 Hz, 0.25 Amperes maximum.
Applications over 240 Volts AC require optional transformer(s).
24 Volts AC, 1 Ampere maximum.

COMPONENTS

FUSES

One located on each printed circuit board (2).
Type AGC, 250 volts, fast blow, 1 Ampere.

Pumps

Peristaltic, dual roller, self-priming, and self-checking.

Typical Operating Conditions

115, 208 or 230 VAC
Inlet vacuum - 8 inches of mercury
Detergent outlet pressure - 5 psi
Rinse & sanitizer/destainer outlet pressure - 30 psi
Tubing material - silicone
Fluid at one centipoise.

Speed & Displacement (When Operated With B-Flex Tube and Water)

DETERGENT PUMP - (3/16 ID TUBE)

Standard – 100 rpm ----- 5 oz per minute
148 ml per minute

RINSE PUMP - (1/16 ID TUBE)

Adjustable 8 to 80 rpm ----- 0.08 to 0.68 oz per minute
2.5 to 20 ml per minute

SANITIZER PUMP (1/8 ID TUBE)

Adjustable 20 to 100 rpm ----- 0.5 to 2.8 oz per minute
16 to 83 ml per minute

Hydraulic Performance

DETERGENT PUMP

Maximum vacuum ----- 20 inches of Mercury [Hg].
Maximum pressure ----- 20 pounds per square inch.

RINSE AND SANITIZER PUMPS

Maximum pressure ----- 40 pounds per square inch.

Conductivity Probe Input Measurement Range

660 to 12,800 micromhos when using 0.4 constant (K factor) probes.

Low Detergent Alarm

Audible and visual alarm with adjustable sound level from a low setting of essentially silent to a high setting providing 93 dB at a distance of 3.1 ft (1 meter) and at a frequency of 2.5 KHz.

LED blinks 2 times per second.

Automatic timeout alarm sounds if setpoint cannot be reached in 24 seconds.

Note

Design and specifications are subject to change without notice.

INSTALLATION & SETUP PROCEDURES

PHYSICAL INSTALLATION

CAUTION: SAFETY

- Refer installation and service to qualified personnel only.
- Installation must comply with all applicable plumbing & electrical codes.

1. Mounting the Unit

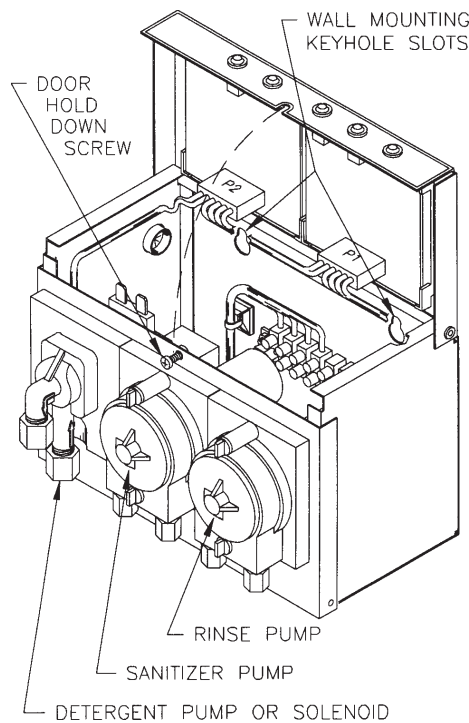

Carefully select a place to mount the unit. Remember that there must be room around it for access to switches, wires and tubing, and to swing the top door open for both installation and maintenance. The unit is normally mounted against a stable vertical surface with the pumps side-by-side and their tube openings at the bottom. Avoid steam and other sources of moisture, such as from spray or splash; and do not subject it to temperatures outside the range from +36 °F to +120 °F (+2 °C to +49 °C).

Wall mounting can be accomplished using the two keyhole slots on the interior back panel. Wall anchors and mounting screws are provided in the installation kit. No mounting template is required. A mounting bracket kit is available for dishwasher top mounting applications (see Spare Parts & Accessories section).

The PCB door is held closed by a captive hold down screw that fits through a slot in the door. The pump door is held closed by the PCB door. There are no user serviceable parts that are accessible without proper tools.

2. Installing the Conductivity Probe

If available and suitable for the application, use the washer manufacturer's predrilled access hole. Otherwise, punch a $\frac{7}{8}$ inch (2.2 cm) hole through the wash tank in a location that will provide accurate sampling of the detergent solution. Typically, probes are mounted about 4 inches (10 cm) above the bottom of the tank, away from any heater elements, corners or any mechanical parts (such as water level floats). Smooth the edges so gaskets will seal well, and mount the probe.

3. Installing the Detergent Bulkhead Fitting

Punch a hole in the wash tank in a suitable location above the water level line. See Appendix C. For best results, mount the fitting directly above the point where the probe is located. All necessary installation parts (for typical installations) are included in the installation kit supplied with the unit, or with the powder/solid detergent hopper.

4. Connecting Chemical Supply Lines

Illustrations showing installation and hookup are in Appendix C.

• Detergent, Rinse & Sanitizer Pump Input Lines

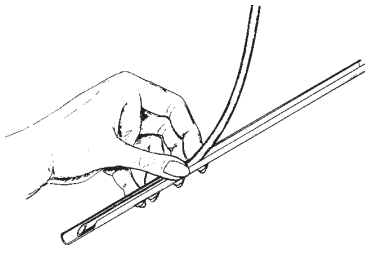

Connect the $\frac{1}{4}$ inch (6 mm) (detergent) or $\frac{1}{8}$ inch (3 mm) (rinse & sanitizer) polyflow line to the polyflow nut on the left (suction side) of the pump squeeze tube. Tighten the nuts on the fittings. Make sure the connection is airtight. Run the polyflow lines to the chemical drums, and secure the end of each supply line into its respective container. Use a snap-in standpipe for liquid detergent lines.

The snap-in standpipe is a rigid three-quarter round “u” shaped tube section 18 inches (46 cm) long. Cut the polyflow line at a 45° angle. The feed end of the polyflow line can be pressed into the open part of the “u”. Leave the bottom of the standpipe slightly lower than the inlet of the polyflow line.

• Detergent Pump Output Line (Left Pump)

Connect the $\frac{1}{4}$ inch (6 mm) polyflow line to the polyflow nut on the right side of the detergent pump squeeze tube. Tighten the nut on the fitting. Run the feed line to the detergent bulkhead fitting (see Appendix C). Use as short a run of line as possible and keep the lines away from steam pipes, open flues or any other place where they may be accidentally damaged by the machine operators. In this and other output line runs, always try to avoid uphill runs. Secure the polyflow line into the fitting.

• Sanitizer Pump Output Line (Center Pump)

Connect the $\frac{1}{4}$ inch (6 mm) polyflow line to the polyflow nut on the sanitizer pump squeeze tube. Tighten the nuts on the fittings. Run the feed line to the plastic sanitizer injector/check valve fitting (see Appendix C). The sanitizer should be injected into the rinse water line separately from the rinse agent. If this is a destainer application, the output will be fed into the wash tank with the same type of fitting as is used for the detergent feed. Again, use as short a run of line as possible and keep the line away from any place where it may be accidentally damaged.

• Rinse Pump Output Line (Right Pump)

Connect the $\frac{1}{8}$ inch (3 mm) polyflow line to the polyflow nut on the rinse pump squeeze tube. Tighten the nut on the fitting. Run the feed line to the plastic injector/check valve fitting. Follow the instructions included in the installation kit.

Important Operating Note

Although the rinse pump is capable of pumping against 40 pounds of pressure per square inch (2.8 kg. psc), it is not advisable to operate at this level. The rinse pump tubing life will be severely shortened. Most dishwasher manufacturers specify no more than 25 psi (1.8 kg. psc) in the washer rinse line, and the water pressure should always be below this specification to ensure optimum performance and results.

5. Plumbing Connections to Water Solenoid

Solenoids are used to supply water to a powder or solid detergent hopper. The compression fittings on the solenoid inlet and outlet accept either $\frac{1}{4}$ inch polyflow plastic line or $\frac{1}{4}$ inch copper pipe (pipe not supplied with unit). Follow the flow arrows on the solenoid when making connections. Consult the instructions supplied with the detergent hopper. Regulate water pressure to the hopper in the range from 20 to 30 psi (1.4 to 2.1 kg. psc).

Note

If using the optional Pressure Switch, consult the instructions with the installation kit.

ELECTRICAL CONNECTIONS

⚠ CAUTION

- Dangerous voltages are wired into this unit and are present in the cabinet even when the Power Switch is set to Off.
- Refer installation and service to qualified personnel only. Installation must comply with all applicable electrical codes.

Locate electrical circuits on the dishwasher that provide power as described in the Specifications section of this manual. Power must be supplied to the NS-1000 only when the dishwasher is in operation and must be turned off when the dishwasher is off. Connect the two legs of each power source to its appropriate terminals inside the cabinet as detailed on the power wiring label inside the cabinet. Always connect a ground wire from the ground lug provided in the NS-1000 cabinet to the ground at the washer power source.

For a two transformer NS-1000 system, provide:

- Detergent power from a source which is on during the wash cycle, such as wash pump contactors (DPS1 & DPS2 in a Hobart machine).
- Rinse power from a source which is on during the rinse cycle, such as a rinse fill solenoid (RPS1 & RPS2 in a Hobart machine).

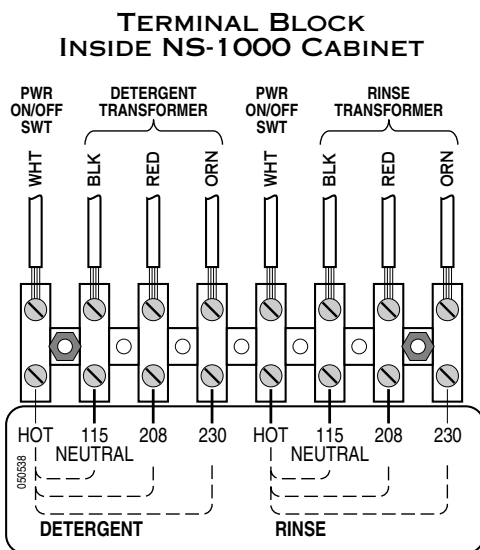

INCOMING POWER

For a one transformer NS-1000 with a pressure switch, connect to a power source which is on during the entire wash/rinse cycle to the detergent side (left side) of the terminal block.

For a one transformer NS-1000 without a pressure switch connect the power from the washer rinse solenoid to the detergent side (left side) of the terminal block.

There are 24 Volt versions of the NS-1000 available without internal transformers. They should also be wired through the terminal block; the wiring label will indicate the detergent and rinse power positions.

Note

Rinse power—for installations with internal boilers (calorifiers), refer to the instructions in Appendix A.

Probe Connections

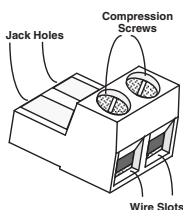

Remove the probe connector from the detergent circuit board and loosen the compression screws. Bring the probe wires into the unit through the access hole in the left side, then insert them into the removable plug's wire slots. Tighten the two compression screws to secure the wires. Insert the plug into its jack on the detergent circuit board.

EXTERNAL CONTROLS DESCRIPTIONS

Power ON/OFF Switch

This double pole single throw switch provides control over the incoming power to the NS-1000. It will accommodate one or two transformers.

Detergent Prime Switch

There must be detergent power to the NS-1000 for this switch to work. The detergent pump will run as long as this switch is depressed when in the probe mode. In the probeless mode, the switch need only be pushed to start an initial feed cycle.

Rinse Prime Switch

There must be rinse power to the NS-1000 for this switch to work. The rinse pump will run as long as this Switch is held depressed.

Sanitizer Prime Switch

There must be rinse power to the NS-1000 for this switch to work. The sanitizer pump will run as long as this switch is held depressed.

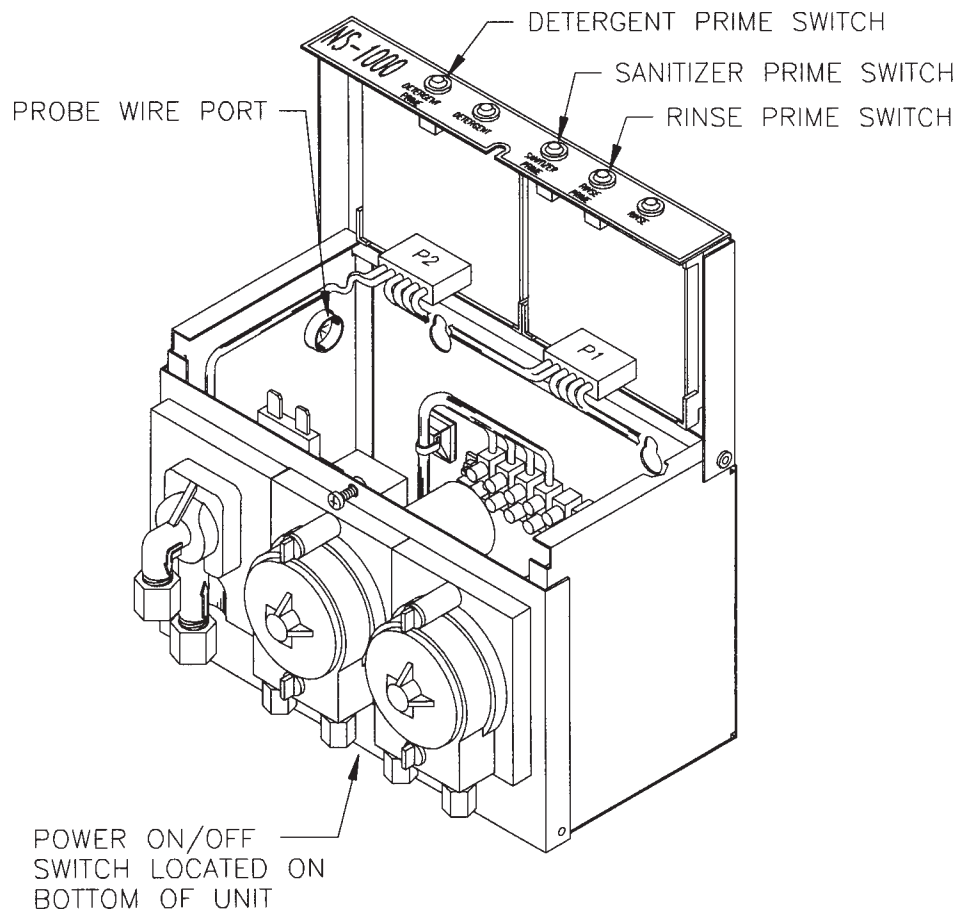

INTERNAL CONTROLS DESCRIPTION

Internal Controls Diagram

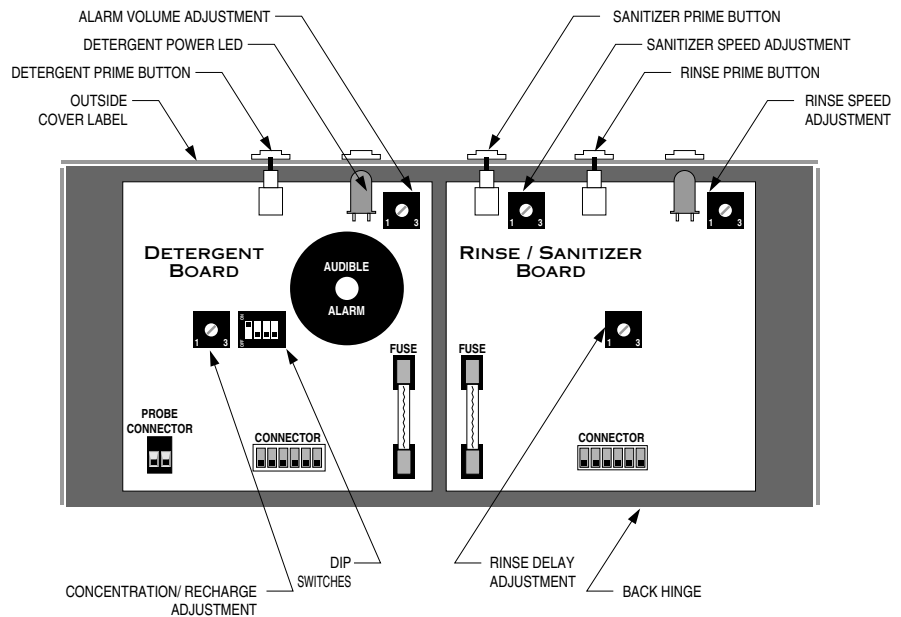

CONTROL BOARDS LOCATED UNDER TOP COVER

Detergent Board

Quad Control DIP Switches

Switch 1 - Mode Select

- On for probe.
- Off for probeless.

Probe Operation

Switch 2 - Detergent Concentration Range Select

- On for high range (2,900 to 12,800 micromhos).
- Off for low range (640 to 2,900 micromhos).

Switch 3 - Overfeed Stop Select

- On to enable stop (detergent feed stops after 3 minutes).
- Off to disable stop.

Switch 4- Reduced Detergent Injection Rate Select

- On for a 50% rate (4 seconds on & 4 seconds off).
- Off for a 25% rate (1 second on & 3 seconds "off").

Probeless Operation

Switch 2, 3 & 4 - Initial Charge Select

Switch combinations give an initial charge time.

Range - 0 to 20 times the recharge time.

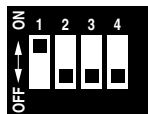

Detergent Concentration/Recharge Adjustment Dial

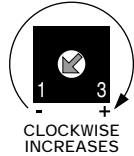

With Probe

- This dial setting determines the detergent concentration setpoint.
- Low Range - 640 to 2,900 micromhos.
- High Range - 2,900 to 12,800 micromhos.

Probeless

This dial setting determines the length of time the detergent pump will be on when power is applied (Recharge Time).

Range - 0 to 16 seconds.

Alarm Volume Adjustment Dial

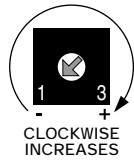

This dial is used to increase or decrease the sound level of the alarm.

Range - Off to 93 dB.

Rinse/Sanitizer Board

Rinse Pump Speed Adjustment Dial

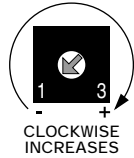

This dial adjusts the rinse pump's flow rate.

Range - 0.05 to 0.88 oz per minute.
1.6 to 26 ml per minute.

Rinse Pump Delay Adjustment Dial

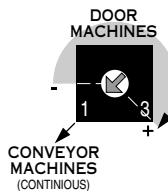

This dial sets the rinse pump delay after the rinse signal is received.

- Conveyor Range - No delay.
- Door Range - 0 to 10 second delay.
15 seconds fixed run time.

Sanitizer Pump Speed Adjustment Dial

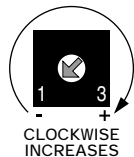

This dial adjusts the sanitizer pump's flow rate.

Range - 0.5 to 2.8 oz per minute.
16 to 83 ml per minute.

SETUP PROCEDURES

Detergent System with Probe

Set DIP Switch 1 to **ON**.

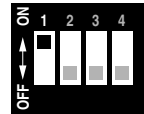

Concentration Adjustment

PRESET METHOD

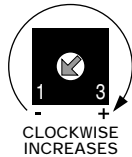
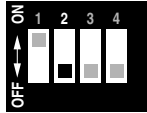

1. For concentration range, set DIP switch 2 (up for high range and down for low range) and the Detergent Concentration/Recharge Adjustment dial. Use similar washer experience if available or start with low range and the dial at a minimum setting.
2. Fill the wash tank with water and make sure that the water is heated to the correct wash temperature.
3. Turn on the wash motor to agitate the solution. Turn on the NS-1000 unit and allow the detergent to feed until it stops.
4. Check the concentration. If necessary, adjust the dial setting, and/or the range setting of the switch to correct for differences between the actual and desired concentration.
5. Rerun the test if necessary.

PRECHARGED WASH TANK METHOD

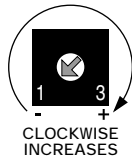
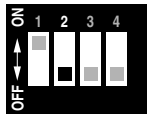

1. Set DIP switch 2 to the appropriate range for the product being used. Powder and high concentration product are normally used in the high range, and liquid detergents tend to be in the low range of detergent concentration. Begin with the Detergent Concentration/Recharge Adjustment dial fully counterclockwise (minimum).
2. Fill the wash tank with fresh water and make sure that the water is heated to the correct wash temperature.
3. Manually add into the wash tank the amount of detergent that your calculations show will provide optimum results.
4. Turn on the washer to agitate the solution.
5. Measure the detergent concentration using any of the standard methods (pH, titration, etc.). Manually add detergent, or dilute the wash tank water, until the desired concentration is reached.
6. Slowly increase the setpoint dial until the detergent pump just turns on, or the solenoid clicks. Set the dial back slightly until the feed stops.

LOW DETERGENT ALARM TEST

Delay is fixed and is not adjustable.

1. To check and/or set the alarm, remove the detergent suction (input) line from the chemical supply container.
2. Run the pump until the wash tank feed line is empty. The alarm should turn on after a delay of 24 seconds if the wash tank detergent concentration setpoint has not been reached. See the Operation information at the end of this section.

- Reinsert the input line into the chemical source and run the pump until the wash tank feed line is full. The alarm may turn off while chemical is being fed if the wash tank concentration is increasing.

OVERFEED STOP/STOP DEFEAT

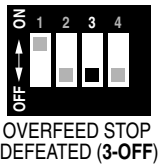

- When DIP switch 3 is set to ON, the detergent feed will be completely stopped whenever it has run for more than 3 minutes without reaching the detergent concentration setpoint.

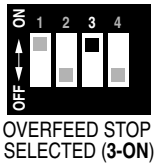

- This can be tested by repeating the LOW DETERGENT ALARM TEST described above. The pump will stop after 180 seconds. Refer to the Operation information at the end of this section.

- In cases where an extended feed time is normal, the switch should be set to OFF, defeating the Overfeed Stop function and allowing the detergent pump to continue to feed.

REDUCED DETERGENT INJECTION RATE



The injection rate controls the time for the conductivity to change. Set DIP switch 4 to a faster or slower Injection Rate that fits the needs of the installation: ON is a 50% rate (4 seconds on and 4 seconds off), and OFF is a 25% rate (1 second on and 3 seconds off).

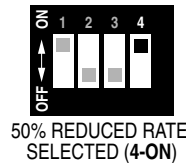

Detergent System Probeless

Set DIP switch 1 to OFF.

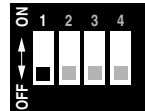

Concentration Adjustments
RECHARGE TIME



- The Detergent Concentration/Recharge Adjustment is a timed function in the Probeless Mode. The amount of time the detergent pump will be on for recharge can be set from 0 (zero) to 16 seconds. Zero is fully counterclockwise, 16 seconds is fully clockwise.
- Preset the Detergent Concentration/Recharge Adjustment dial to the approximate time value desired, and fill the wash tank with water heated to the correct wash temperature.
- Turn on the washer for no longer than 20 seconds to dispense the recharge amount of detergent and agitate the solution. Check the concentration. If necessary, adjust the dial setting to correct for differences between the actual and desired concentration.
- Rerun the test if necessary.

SETTING INITIAL CHARGE AS A MULTIPLE OF RECHARGE

An automatic initial charge of detergent is triggered by the extended presence of the power signal (longer than 20 seconds). You may set the length of this initial charge as a multiple of the recharge time, using DIP switches 2, 3 and 4. Possible multiples are: 0x, 1x, 3x, 5x, 8x, 12x, 15x and 20x.

For example, if you set the Detergent Concentration/Recharge Adjustment dial to 4 seconds and the multiple to 5x, the initial charge is 20 seconds (5 times 4 seconds). You may thus set initial charge in the range from zero seconds (multiple at 0x) to 320 seconds—5 minutes & 20 seconds—(multiple at 20x and Detergent Concentration/Recharge Adjustment dial at 16 seconds).

1. Set the Detergent Concentration/Recharge Adjustment dial.
2. Set the multiple using DIP switches 2, 3 and 4 according to the following:



0 times Recharge Time

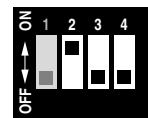

8 times Recharge Time

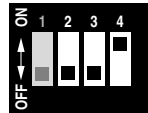

1 times Recharge Time

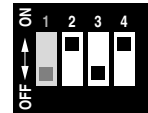

12 times Recharge Time

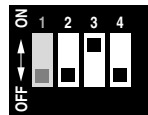

3 times Recharge Time

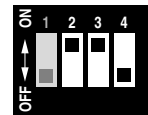

15 times Recharge Time

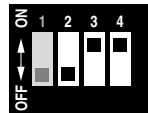

5 times Recharge Time

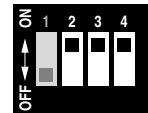

20 times Recharge Time

Rinse System (Probe & Probeless)

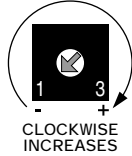

The length of the rinse pump operation is determined by the type of washer. If the washer is a conveyor type, the rinse pump will run as long as rinse power is applied. If the washer is a door type, the rinse pump will run a maximum of 15 seconds after the delay time and for as long as the washer rinse signal remains on.

Rinse Delay Time

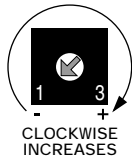

Set the Rinse Delay Adjustment dial according to the type of washer (conveyor or door) being used.

- On conveyor machines, set this dial fully counterclockwise (no delay).
- On door machines, adjust the dial clockwise for a delay that will ensure the desired application of rinse aid in the wash cycle. Minimum delay is at 9:00 O'clock. Range is 0 (zero) to 10 seconds.

Flow Rate Adjustment

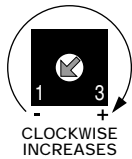

Set the Rinse Speed Adjustment dial to control the pump speed to minimize streaking on the ware. The pump will run at the selected speed after the delay while the rinse power signal is present for a maximum of 15 seconds.

For units with internal calorifiers, see Appendix A.

Sanitizer System

Flow Rate Adjustment

1. Set the Sanitizer Speed Adjustment dial to control the pump speed and obtain the required amount of sanitizer per cycle or rack.
2. Remove the sanitizer delivery line from the pump, or the washer, and measure the quantity to verify the amount of chemical being pumped per cycle or rack.
3. A typical application for sanitizer for a low temperature washer, per FDA specification, is 50 to 150 parts per million (ppm).

Sanitizer Feed with Rinse

The sanitizer pump will run:

- In conveyor mode, when the rinse signal is present.
- In door mode, when the rinse pump is operating and during the rinse pump delay.

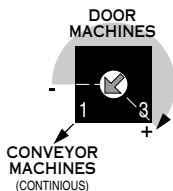

OPERATION

Alarms & Indicators

The internal audible alarm and the Detergent and Rinse indicator lamps on the front panel together provide the following operating status information:



Detergent Indicator Lamp

- Power from washer Lamp on continuously.
- Detergent feeding Lamp flashing slowly.
- Detergent low Lamp flashing rapidly and alarm pulsing.
- Overfeed
 - Stop Lamp and alarm on continuously.
 - Stop Defeat Lamp flashing rapidly and alarm pulsing.

Rinse Indicator Lamp

- Power from washer Lamp on continuously.
- Rinse feeding Lamp flashing slowly.
- Rinse delay Lamp flashing rapidly.

MAINTENANCE

1. PERIODIC MAINTENANCE

1.1 Pump & Squeeze Tube Replacement Schedule

Every installation is different (chemicals, tube runs, operating frequency, etc.), therefore a precise tube replacement schedule cannot be specified. With use the tube slowly evolves from round to oval, and the amount of chemical pumped decreases. By regularly checking the amount of chemical pumped, the user can determine general tube life. It is recommended that the user closely monitor the time it takes for the original tube to reach the end of its flex life, and then establish a replacement schedule. Replacing tubes at regularly scheduled intervals ensures more accurate product use and reduces service calls. In general, short feed lines of a large diameter will improve pump tube life.

Note
It is very important not to let the tubes become worn to the point where they tear and allow chemicals to saturate the pump housing.

1.2 How to Replace Pump Cartridges

It is recommended that only the cartridge replacement be done in the field. Tube replacement can be accomplished later. See the Pump Assembly exploded view drawing in Appendix D. Note that each pump has a different size squeeze tube and polyflow nuts.

- Detergent Pump 3/16 inch tube ID 1/4 inch nuts
- Rinse Pump 1/16 inch tube ID 1/8 inch nuts
- Sanitizer Pump 1/8 inch tube ID 1/4 inch nuts

1.2.1 To Remove

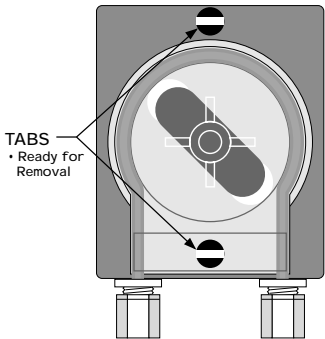

- Turn off power to the unit.
- Remove the pump from the motor housing by twisting the two quarter turn fasteners at top and bottom (rotate the tabs 90° to horizontal).
- Remove the old pump from the motor housing.
- Remove the supply and feed lines from the old pump and connect them to the new pump.

1.2.2 To Install

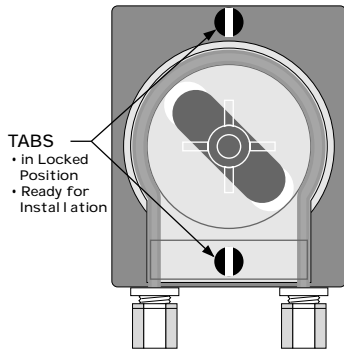

- a. Install the new pump as follows:
 - Turn the tabs to vertical.
 - Mesh the pump drive spline with the motor gear (rotate pump until it engages).
 - Hold the pump in the vertical position.
 - Press the tabs into the motor housing until you hear a distinct click.
- b. Turn on power to the unit.

1.3 How To Replace Pump Motor & Solenoid Subassemblies

1.3.1 To Remove

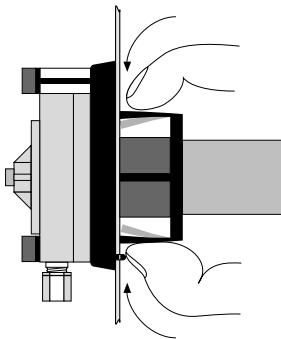

- a. Turn off power to the washer.
- b. Remove the supply and feed lines from the old pump motor/solenoid and connect them to the new pump motor/solenoid.
- c. Remove the quick disconnect tabs from the electrical connections at the back of the pump motor/solenoid. Care should be taken to keep pump wires pairs together.
- d. The pump motor/solenoid assembly uses two flexible ears to hold it in the cabinet. To remove it, compress the two ears enough to allow it to slide out through the hole in the cabinet.

1.3.2 To Replace

- a. Locate the alignment tip of the pump motor/solenoid housing so it is in the down position.
- b. Slide the pump motor/solenoid housing into the cabinet hole. The holding ears will be compressed by the sheet metal, then expand to hold the pump motor/solenoid in place. Verify that both ears did pop out and are locked in place.
- c. Reinstall the quick disconnect tabs on the electrical connections at the back of the pump motor/solenoid. Turn on the power. Use the Prime button to verify the proper pump rotation (clockwise). Reposition the motor wires if necessary to change direction.

1.4 Cleaning The Probe

The conductivity probe tips (electrodes) must be cleaned on a regular basis to ensure control accuracy. The water conditions (such as water hardness) and the type of soil load will be the primary factors in determining a cleaning schedule.

2. TROUBLESHOOTING

Refer to the exploded assembly drawings, item lists, and the complete unit wiring diagram in Appendix D, and the circuit board illustration in the Internal Controls Description. To order items from the drawings, find the item on the drawing and note its sequence number, locate it in the item list using its sequence number, and order using the item number.

2.1 No Power

2.1.1 Is the On/Off switch on?

2.1.2 Is proper line power voltage connected to the power input terminals in the unit? Check both transformers. Is a circuit board fuse blown?

2.1.3 With the power wiring harnesses unplugged from both circuit boards, is 24 volts AC measured across both sets of transformer secondary wires when power is supplied from the washer? If not, replace the transformer(s). If yes, replace the circuit board(s).

2.2 Properly Rated Fuse Blows Repeatedly:

2.2.1 Is there a mechanical problem with a motor or solenoid (*e.g.*, jammed tubing or frozen gears in the gearbox)?

2.2.2 Do motor and/or solenoid resistance measurements fall in the approximate range from 4 to 100 ohms? If yes, go on to the next step. If no, replace suspect part(s) as a shorted motor or solenoid will cause the fuse to blow.

Note

Resistance must only be measured with the power turned off. A short will typically measure less than 0.2 ohms. An open will typically measure more than 2000 ohms.

2.2.3 Are proper voltages measured across the appropriate output terminals (*i.e.*, detergent drive, rinse drive, and sanitizer drive) when power is applied? If not, replace the circuit board. Maximum voltage is 33 to 34 VDC (without load). Rinse and Sanitizer voltages may be lower depending on the speed setting.

2.2 Detergent Feeds too Often (too much detergent used)

2.2.1 With Probe —

- a. Is the programmed concentration setting correct, or is the actual concentration value close enough to the setpoint to keep the alarm from sounding? Are the probe electrodes clean?
- b. Is a dishwasher problem the cause (such as fill valve on, too much rinse tank overflow into the wash tank, leaking or open drain valve, wash motor not running to agitate the solution)?
- c. While the detergent is feeding, short the two probe wires together (down at the probe). Does the detergent feed stop? If so, see the next two Detergent Troubleshooting subjects. If not, go on to the next step.
- d. Are the probe wires loose or disconnected? If not, short across the two probe wire terminals on the circuit board (instead of at the probe). This should stop

the detergent feeding. Replace the Detergent circuit board if either of these two tests do not stop the detergent feeding.

2.2.2 Probeless —

Check the detergent control setup. (Refer to original setup records.) If wrong, correct. If OK, replace the Detergent circuit board.

2.3 Detergent Does Not Feed at All

2.3.1 Probe —

- a. Are the two probe wires shorted together? If so, the unit will never feed until this is corrected.
- b. Disconnect one of the wires at the probe to cause an open circuit. The Detergent LED should indicate feeding, and the pump or solenoid should function. If so, see the next two Detergent Troubleshooting subjects. If not, go on to the next step.
- c. Disconnect one of the probe wires from the circuit board. If the detergent does not feed (or there is no voltage output from detergent drive), replace the Detergent circuit board.
- d. Before replacing the circuit board, measure the voltage from each of the transformer secondary wires to ground. Approximately 14 volts AC should be present. A transformer short to ground could cause the pump motor to run erratically.

2.3.2 Probeless —

Check the Detergent control setup. (Refer to original setup records.) If wrong, correct. If OK, replace the Detergent circuit board.

2.4 Checking the Detergent System Functions

Important Note

This test may be used to check for proper functioning of all the detergent system functions—probe input circuitry, detergent drive circuitry, and low detergent and overfeed alarms.

2.4.1 With Probe —

- a. Set the DIP Switches as follows: 1 to ON; 2 to ON (high range); 3 to ON (Overfeed Stop enabled); and 4 to ON (50% reduced rate). Rotate the Detergent Concentration/Recharge Adjustment dial fully counterclockwise (minimum).
- b. Connect a forty-seven (47) ohm $\frac{1}{4}$ or $\frac{1}{2}$ watt resistor across the two circuit board probe terminals, or at the end of the probe wires.
- c. Turn power on to the unit. Observe that the detergent pump or solenoid is not feeding.
- d. Slowly increase the Detergent Concentration/Recharge Adjustment dial until the detergent pump runs or solenoid clicks.

- e. Verify that the reduced feed function causes the detergent pump to start and stop (approximately 4 seconds on, 4 seconds off).
- f. Note the low detergent alarm does not occur. Rotate the Detergent Concentration/Recharge Adjustment dial fully clockwise. The detergent pump should run continuously.
- g. Wait for about 24 seconds (after continuous feed starts) until the low detergent alarm sounds.
- h. Wait for 3 minutes until the unit goes into overfeed stop and the overfeed alarm occurs.
- i. Slowly rotate the Detergent Concentration/Recharge Adjustment dial counter-clockwise until the detergent feed stops and any detergent alarm that was sounding stops.
- j. Test completed. If the test does not perform as described, replace the circuit board.

2.4.2 Probeless —

- a. Set the DIP switches as follows: 1 to OFF; 2, 3 and 4 to the ON/OFF combination to be used at the installation being set up (for purposes of this explanation 3x will be used: 3 ON, 2 & 4 OFF). Rotate the Detergent Concentration/Recharge Adjustment dial to its mid position, straight up and down (recharge time approximately 8 seconds).
- b. Turn power on to the unit. Observe that the detergent pump runs or solenoid clicks on, feeds for 8 seconds, and stops.
- c. Observe that, 20 seconds after initial power was applied, the detergent pump or solenoid turns on again and feeds for approximately 24 seconds (3 times the recharge), and then stops.
- d. Wait for at least 3 more minutes and note that no alarms occur, and no more detergent is fed.
- e. Test completed. If the test does not perform as described, replace the circuit board.

2.5 Rinse and/or Sanitizer Pump will Prime but not Feed

2.5.1 Is washer rinse line solenoid opening?

2.5.2 Adjust the feed rate setting on the control board to a rate near mid range.

2.5.3 With the rinse power on from the washer, short across the two pressure switch contacts. The pump(s) should run at the programmed speed. If not, replace the circuit board.

2.6 Rinse and/or Sanitizer Pump will Feed but not Prime

2.6.1 Washer must be in wash/rinse cycle to prime pump.

2.6.2 Replace the circuit board.

2.7 Rinse or Sanitizer Pump will Neither Prime nor Feed

2.7.1 Washer must be in wash/rinse cycle to prime pump.

2.7.2 Does the front panel RINSE LED illuminate when the pressure switch contacts are shorted? If not, replace the circuit board.

2.7.3 When the prime button is pushed, 33 - 34 volts DC should be measured across the motor terminals. When shorting the pressure switch contacts, 0 to 34 volts DC should be measured, depending on what pump speed setting has been selected. This voltage will change as the pump speed setting is increased or decreased.

2.7.4 If voltage in the proper range is present and the pump will still not run, remove the pump cartridge and observe the drive spline while the prime button is pushed. If the drive spline does not turn, replace the motor assembly.

2.8 Rinse or Sanitizer Pump Feeds Continuously

2.8.1 Is the Rinse Pump Delay dial set close to the Conveyor Machine position (fully counterclockwise)? If so, increase the delay time. If not, continue to the next check.

2.8.2 If there is a pressure switch, disconnect one of the wires from the pressure switch. If the motor stops, check to make sure the rinse line solenoid is not on. Also, ensure that there is not a crimp in the pressure line that may hold enough pressure in the line to keep the switch on. Replace the pressure switch after satisfying those two checks. If the speed of the motor cannot be controlled and it continues to run with the pressure and Prime switches disconnected, replace the circuit board.

2.9 Pump Will Not Pull the Chemical Out of the Drum

2.9.1 Too much vacuum created —The supply line in the chemical drum may be up against either the side or bottom, the supply lines may be too long for a viscous product, or there may be a crimp in the intake supply line, thus exceeding the pump's vacuum specifications .

2.9.2 There may be an air leak somewhere in the input supply line. Most often this is caused by inadequate sealing of the supply line into the squeeze tube polyflow nuts.

2.9.3 Squeeze tube is worn and the rollers can no longer squeeze the tube properly. Correct by changing the pump cartridge with the correct size squeeze tube and polyflow nuts for the chemical being pumped.

RECOMMENDED SPARE PARTS & ACCESSORIES

This Parts and Accessories list provides a quick reference source for ordering spare or replacement parts. It also lists accessory items that may be needed which are not on the detailed assembly drawings. To order parts from the listings or drawings, find the part's sequence number (the number in the bubble in the drawing), use that to find the item number, and order using the item number.

Spare Parts

<u>ITEM DESCRIPTION</u>	<u>ITEM #</u>
Printed Circuit Board, Detergent	043958
Printed Circuit Board, Rinse/Sanitizer	043957
Tube, Detergent, 3/16" ID	037617
Tube, Sanitizer, 1/8 ID	050568
Tube, Rinse 1/16" ID	037616
Tube Insert, Detergent / Sanitizer, 1/4T	036969
Tube Insert, Rinse, 1/8T	036982
Tube Fitting, Nut, Detergent/Sanitizer, 1/4T	041903
Tube Fitting, Nut, Rinse, 1/8T	017458
Pump Cartridge, Detergent	039556
Pump Cartridge, Rinse	039549
Pump Cartridge, Sanitizer	050727
Pump Roller Assembly	039550
Quarter turn Pin for Small Pump	036974
Pump Motor Gearbox	051351
Solenoid Assembly	050014
Transformer, 120/208/240 VAC - 24 VAC, 20 W, 60 Hz	018046
Fuse (AGC 250 Volt 1 Amp)	042881
Dummy Cover	036985

Accessory Kits

Pressure Switch Kit	051599
Standard Conductivity Probe Kit	035590
Mounting Bracket Kit	018224

WARRANTY INFORMATION

All Beta Technology Incorporated dispensers are generally warranted against defects in material and workmanship for a period of one year from shipment date, except where otherwise noted. Printed circuit boards have a warranty period of two years, except where otherwise noted. All plastic parts and parts that come in direct contact with chemical products under normal operation are warranted for 90 days, except for squeeze tubing which is warranted to be operational at time of delivery only.

Units will be repaired or replaced which are proven to be defective during the warranty period provided they are returned to Beta Technology Incorporated. No other warranty is expressed or implied. Warranty does not cover equipment abuse or misuse, nor does it cover any consequential liability resulting from performance of the equipment.

TECHNICAL ASSISTANCE

If you require additional technical information, contact our Technical Support Department. Refer to the **Preface** page for telephone numbers.

RETURNING EQUIPMENT FOR REPAIR

If you need to send an item back to be repaired, you must call or write to obtain a Returned Product Report (RPR number) before sending it back. Our Repair Department will provide you with a return number. Please write the RPR number on the outside of the box before sending it back. It is also very helpful to our repair department if you include a note inside the box explaining the nature of the problem. Failure to obtain an authorization number before sending an item in for repair or replacement may delay the return of your equipment.

APPENDIX

A DISHMACHINES WITH INTERNAL CALORIFIERS (BOILERS)

Rinse Pump Delivery

Note

This style of installation has a built-in hot water boiler, also known as a calorifier. The rinse is injected into the boiler at the same time that the detergent is added to the warewasher.

1. For electrical installation, jumper the 24-volt Detergent input power to the Rinse input power at the appropriate terminals in the unit.
2. For the Rinse Pump Delay setup, always set the delay to 0 (zero) for door machines.
3. Set the Rinse Pump Speed to deliver the required rinse additive volume within the 15 seconds of run time.
4. The following list shows the correlation between Rinse Pump Speed setting and amount of Rinse product pumped when the delay is set to 0.

<u>RINSE PUMP DIAL SETTING</u>	<u>TOTAL AMOUNT OF PRODUCT PUMPED</u>
7 o'clock	none
9 o'clock	1.5 ml.
11 o'clock	5.5 ml.
1 o'clock	6 ml.
3 o'clock	6 ml.
5 o'clock	6 ml.

Rinse Pump Installation

RINSE INJECTION TIMING

The Rinse and Detergent Signal inputs on the PC board are tied together. Consequently, both are fed into the system at the same time. However, detergent is fed into the wash reservoir while the Rinse aid is fed into the boiler (water source).

B TYPICAL INSTALLATION EXAMPLES

CONVEYOR TYPE WASHER & NS-1300 S

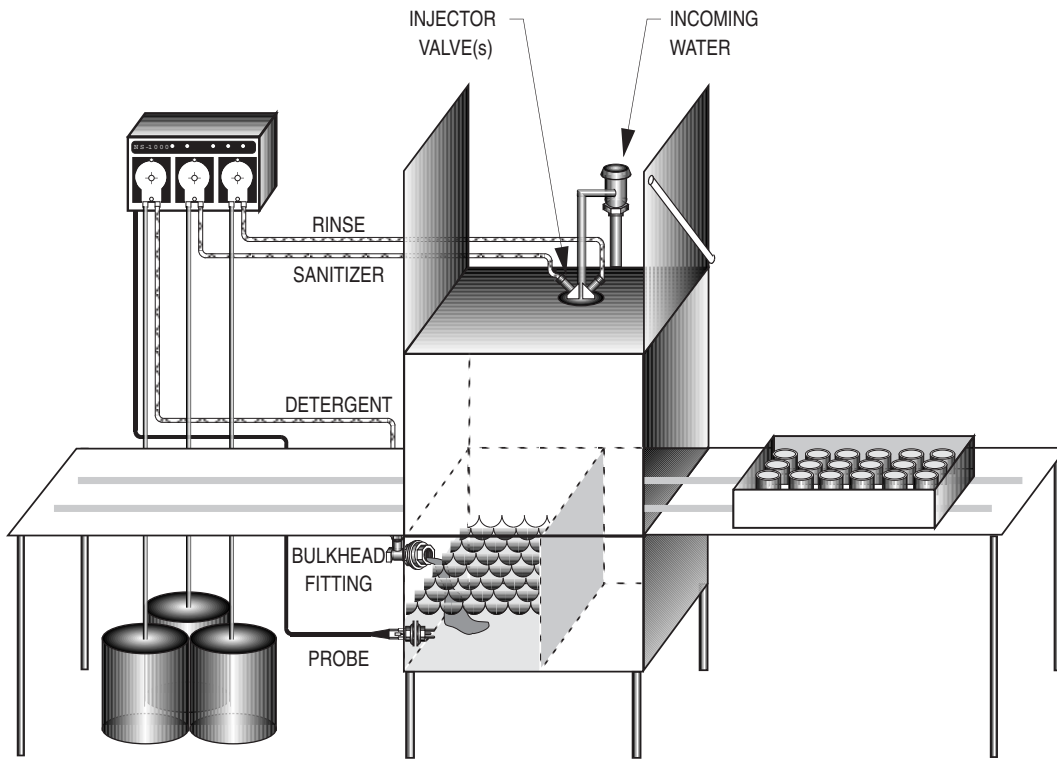

DOOR TYPE WASHER & NS-1200 SR

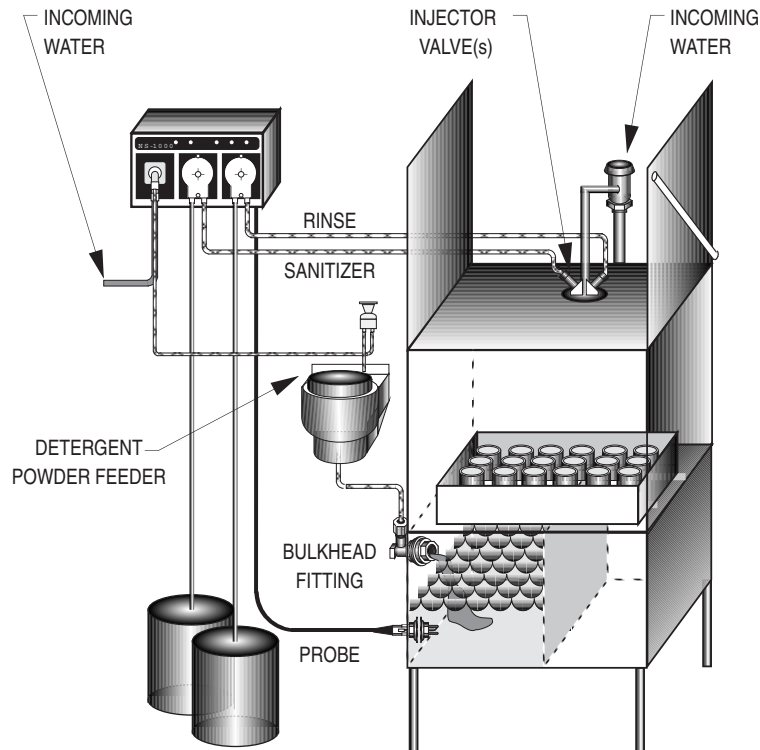

C DIAGRAMS & DRAWINGS

Sequence to Item Number List

SEQ #	ITEM #	ITEM DESCRIPTION
1	051396	NS-1000 Base Assembly Enclosure, Stainless Steel
2	039457	NS-1000 Front Door, Stainless Steel
3	039456	NS-1000 Top Door, Stainless Steel
4	051351	Gear Motor Assembly, 5 oz. Pump
5	036985	5 oz Pump Dummy Cover
6	018046	Transformer, 120/208/240 VAC In, 24 VAC Out, 20 Watts Power Rating
7	035504	Terminal Block 10 mm, Screw down type, 8 connections
8	041711	Terminal Block, Single connection, Panel Ground Lug, for 8 AWG Wire
9	037598	Double Pole-Single Throw ON/OFF Panel Rocker Switch, 4 A 250 VAC Rating
10	050538	Terminal Block Label, 8 Position, Detergent/Rinse, 115 - 230 VAC
11	043957	NS-1000 Rinse/Sanitizer Printed Circuit Board, 24 VAC
12	043958	NS-1000 Detergent Printed Circuit Board, 24 VAC
13	036983	Printed Circuit Board Holder
14	039458	NS-1000 Cover Label, 5 holes, White Print
17	039460	Boot, Switch, Santoprene, NS-1000
18	044144	Adhesive Plastic Sheet, 3.22" X 3.38"
19	037600	Nylon Bushing with Fingers, 5/16" Diameter
20	036982	5 Ounce Pump Insert, 1/8"
21	036969	5 Ounce Pump Insert, 1/4"
22	017458	Tube Fitting, Nut, Vp, 1/8"
23	041155	Pop Rivet, 1/8" X 1/8"
24	041175	3/16" Diameter Hex Standoff, 4/40 X 1/2" Long
25	041088	Kep Nut, 6-32
26	040992	Phillips Pan Head Screw, 6-32 X 3/4" Long
27	050549	Crimp Terminal, 18 to 22 AWG, 3/16" Long, Female, Right Angle
28	041717	Crimp Terminal, 18 to 22 AWG, 1/4" Long, Male
29	041903	Tube Fitting, Nut, Vp, 1/4"
30	037616	Tubing, Norprene, 0.062" ID X 5.25" Long (Rinse)
31	037617	Tubing, Norprene, 0.188" ID X 5.25" Long (Detergent)
32	037299	NS-1000 Harness: 1 Transformer, 3 Pumps, 2 Printed Circuit Boards
33	039732	White 18 AWG Wire, 10" Long, W/QDC

SEQ #	ITEM #	ITEM DESCRIPTION
34	036964	Front Housing for 5 Ounce Pump
35	036965	Rear Housing for 5 Ounce Pump
36	036967	Black Delrin Spinner for 5 Ounce Pump
37	043981	White Delrin Roller, 0.496" OD
38	036980	Delrin Roller Shaft, 0.188" OD X 0.7" Long for 5 Ounce Pump
39	039455	Stainless Steel Spinner Shaft, 0.25" Diameter X 1.25" Long
40	036974	Quarter Turn Pin for 5 Ounce Pump
41	043839	Stainless Steel Phillips Pan Head Screw, #4 X 3/8" Long
42	039704	NS-1000 Harness: 2 Transformers, 3 Pumps, 2 Printed Circuit Boards
43	039705	NS-1000 Harness, 24v input, 3 Pumps, 2 Printed Circuit Boards
44	039734	Orange, 18 AWG Wire, 10" Long W/QDC
45	039733	Red 18 AWG Wire, 10" Long W/QDC
48	041318	Small Tie Wrap
49	041323	Backing for Tie Wrap
50	050014	NS-1000 Detergent Solenoid Assembly
51	051599	Pressure Switch Accessory Kit
52	038090	Hazard Warning Label, Disconnect Power, High Voltage
54	042035	Silicone Grease Lubricant
55	050568	Tubing, Norprene, .125" ID x 5.25" Long (Sanitizer)
56	039409	Ground Screw Label
--	SEQ #	ITEM # ITEM DESCRIPTION
1	050015	Valve Body
2	050016	Mounting Plate
3	050017	Clip
4	050171	Coil
5	038448	Diaphragm/Plunger kit
6	039662	Filter
7	041905	Tube Nut
8	050172	Screw
9	043839	Screw

NS-1000
FINAL ASSEMBLY
Dwg N° 10835 REVA
SHT 1 of 6

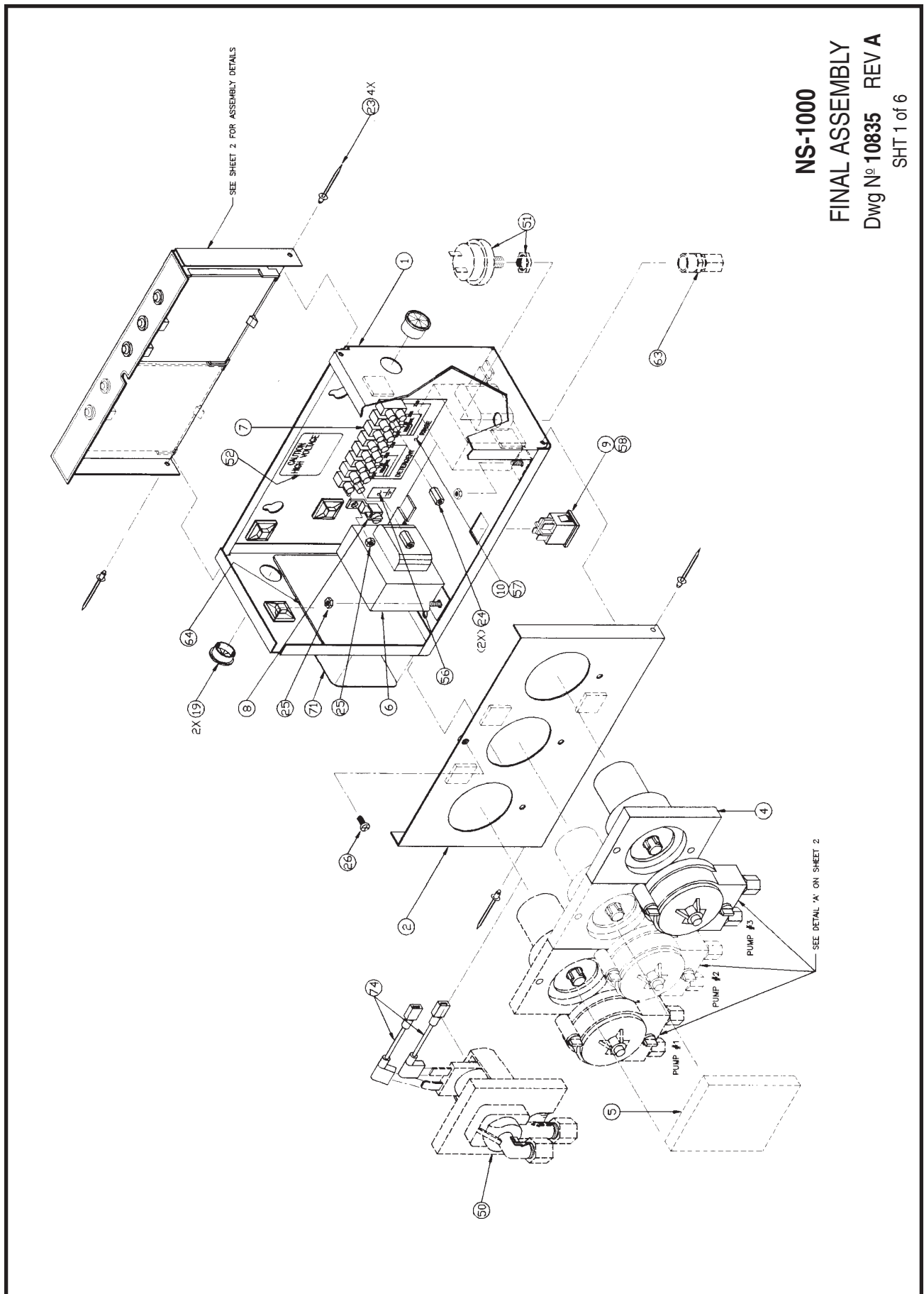

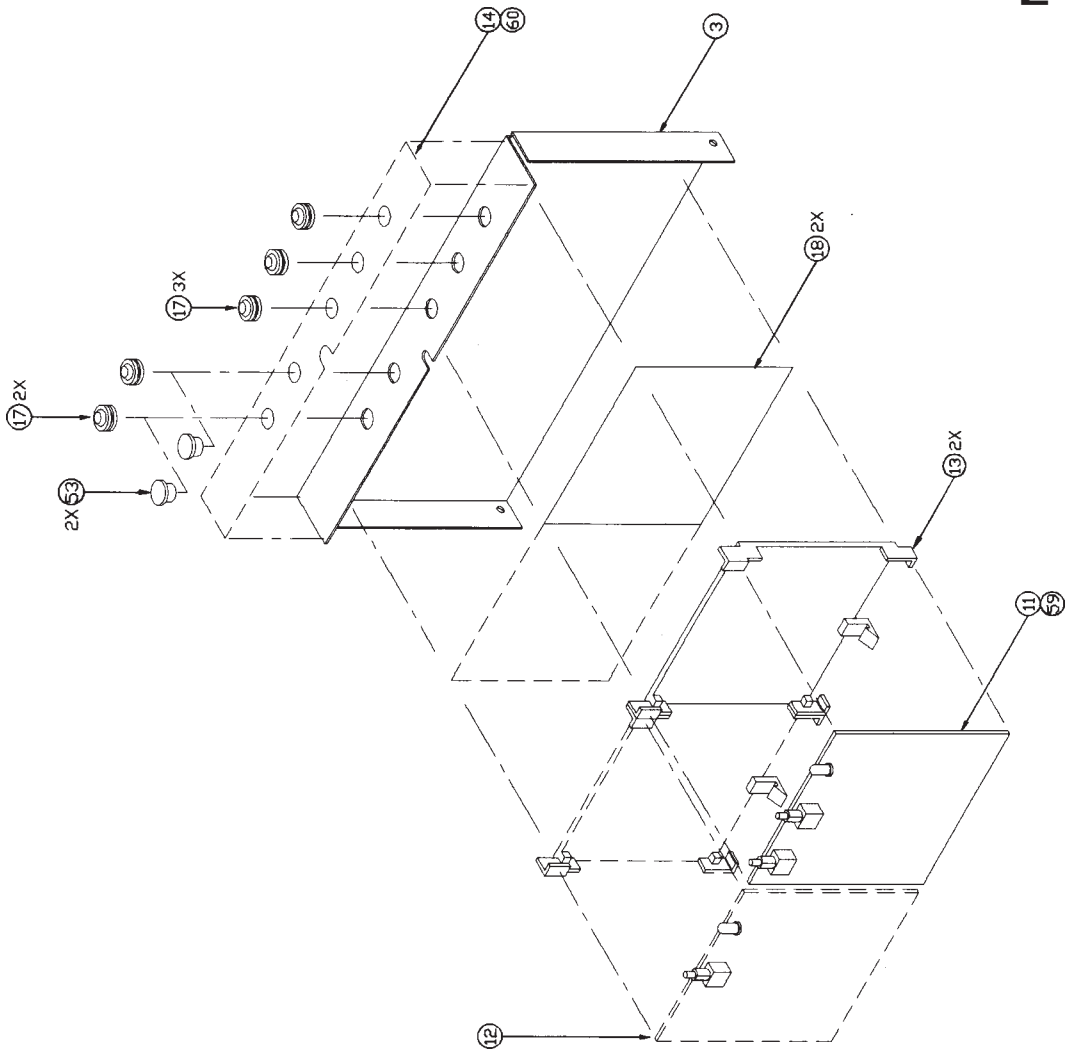

**NS-1000 FINAL
ASSEMBLY**
Dwg N° 10835 REV A
SHT 2 of 6

NS-1000
WIRING DIAGRAM
Dwg N° 10835 REV A
 SHT 3 of 6

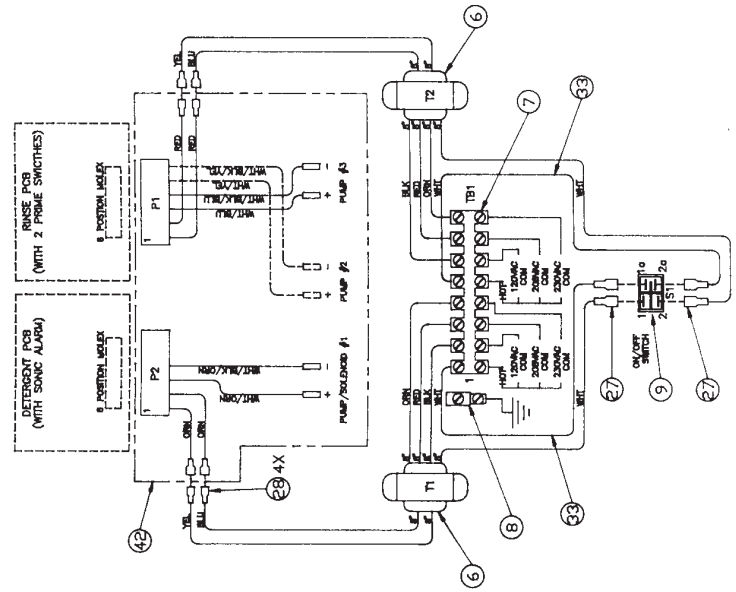

2. TRANSFORMERS, 2. PCB'S

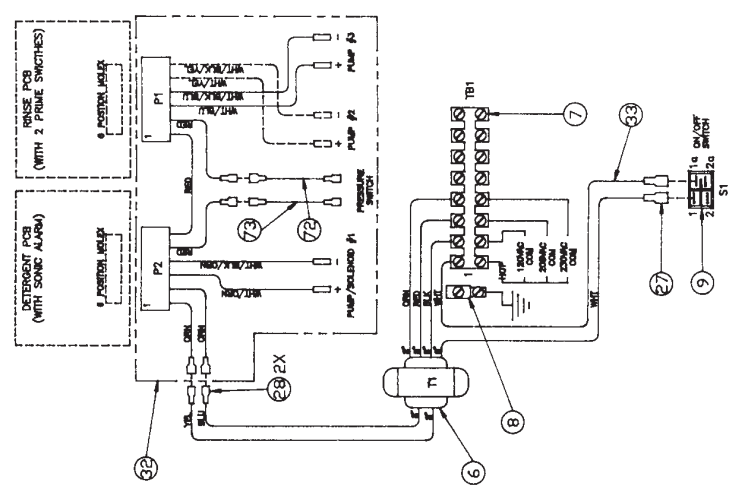

1. TRANSFORMER, 2. PCB'S W/PRESSURE SWITCH

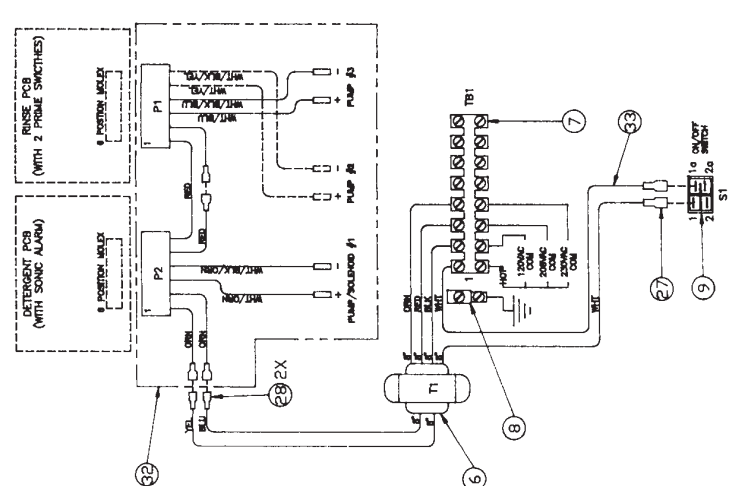

1. TRANSFORMER, 2. PCB'S

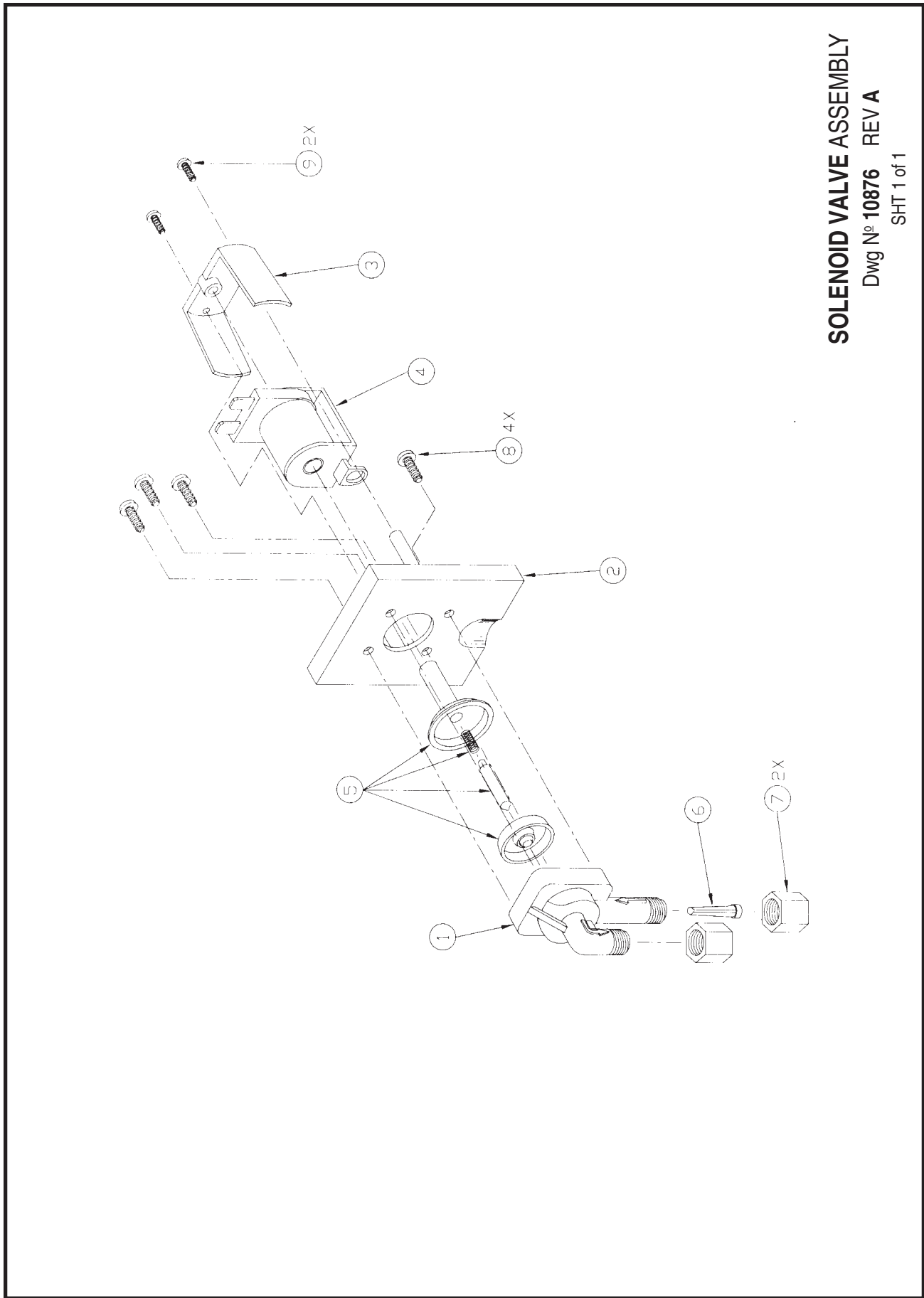

SOLENOID VALVE ASSEMBLY

Dwg No 10876 REV A

SHT 1 of 1

NS-1000 PUMP ASSEMBLY

