

# NS-2000 SERIES

WAREWASHING DISPENSER

INSTALLATION AND OPERATING MANUAL



# PREFACE

---

This manual describes how to install, set up, operate and maintain the NS-2000 Warewashing Dispenser.

Material in this manual is subject to change without notice. Manual revisions will be made on an as needed basis. Special circumstances involving important design, operation or application information will be released via Technical Service Bulletins.

© Copyright 1993, 1994, Beta Technology, Inc.

## Company

**Beta Technology, Inc.**  
151 Harvey West Blvd.  
Santa Cruz · CA  
U.S.A. · 95060-2142

## Telephone

In the continental US, call toll free ..... 800 · 215 · 6415  
Inside California, call ..... 408 · 426 · 0882  
FAX ..... 408 · 423 · 4573

# TABLE OF CONTENTS

---

## INTRODUCTION & EQUIPMENT DESCRIPTION

Application Description .....	1
Terms .....	2

## SPECIFICATIONS

Physical Dimensions, Construction & Mounting .....	3
Operating Conditions .....	3
Components .....	3

## INSTALLATION & SETUP PROCEDURES

Physical Installation .....	5
Electrical Connections .....	8
External Controls Description .....	9
Internal Controls Description .....	10
Setup Procedures .....	12
Operation .....	16

## MAINTENANCE

1. Periodic Maintenance .....	17
2. Troubleshooting .....	19
Recommended Spare Parts & Accessories .....	23
Technical Assistance .....	24
Product Repair .....	24
Special Note .....	24

## APPENDIX

A Dishmachines with Internal Calorifiers (Boilers) .....	25
B Typical Installation Examples .....	26
C Diagrams & Drawings .....	27
Sequence to Item Number List .....	27
NS-2000	
Two Pump Enclosure Final Assembly .....	29

# INTRODUCTION & EQUIPMENT DESCRIPTION

## APPLICATION DESCRIPTION

The NS-2000 Warewashing Dispenser satisfies a wide range of recirculating and fill & dump machines. Four models provide probe-controlled or probeless chemical delivery for two products—detergent (liquid, powder or solid) and liquid rinse aid.

Warewashing machine types supported include:

- Single-rack door machines
- Low-volume conveyor machines
- High-temperature machines

The following table lists available features and configurations.

NS-2000 TWO-PRODUCT CABINET STANDARD CONTROL FEATURES													
MODEL NUMBERS	DETERGENT		RINSE	TRANS-FORMER	DETERGENT CONTROL/ALARMS					RINSE CONTROL			
	Pump	Solenoid	Pump		PROBELESS	PROBE				Adj. Feed Rate	Adj. Feed Delay	Fixed Feed Stop	Prime Switch
					Adj. Recharge	Man. & Auto. Init. Chg.	Adj. Set Point	Adj. Volume	Overfeed Stop Select				
NS-2000 	1		1	0 or 1	STD	STD	STD	STD	STD	STD	STD	STD	STD
NS-2100 P 		1	1	0 or 1	STD	STD	STD	STD	STD	STD	STD	STD	STD
NS-2100 D 	1			0 or 1	STD	STD	STD	STD	STD	STD	STD	STD	STD
NS-2000 R 		1		0 or 1	STD	STD	STD	STD	STD	STD	STD	STD	STD

### ICON KEYS



PRODUCT PUMP  
DETERGENT SOLENOID

Standard with all models: On/Off Switch; Prime Switch(es).

Optional with appropriate models: Pressure Switch (only one transformer installed with this switch).

Two versions of probeless operation are available:

#### 1. Standard Probeless Operating Mode

- Initial charge is DIP switch set.
- Recharge time is dial set.
- Rinse pump is operated at a variable speed.

#### 2. XT2 Probeless Operating Mode

- Recharge and initial tank charge are dial set.
- Rinse pump is run at a fixed speed for an adjusted period of time.

## TERMS

**The following definitions apply throughout this manual:**

**Line**—Polyflow or other plastic tubing that carries chemical supply from the source to the pump or from the pump to the washer.

**Tube & Squeeze Tube**—Tubing installed and designed to be used in peristaltic pumps.

**Pipe**—Metal or plastic rigid pipes, plumbing.

# SPECIFICATIONS

## PHYSICAL DIMENSIONS, CONSTRUCTION & MOUNTING

### SIZE

5 ½ H x 5 ½ W x 5 ⅞ D inches  
(14 x 14 x 14.3 cm)

### WEIGHT

NS-2200 .....5.3 lbs (2.40 Kg)  
NS-2100 R .....5.5 lbs (2.50 Kg)  
NS-2100 D .....5.1 lbs (2.30 Kg)  
NS-2000 R .....5.3 lbs (2.40 Kg)

### CABINET

Type 304 Stainless Steel

### MOUNTING

Wall mounted with two (2) keyhole slots in the backplate.

## OPERATING CONDITIONS

### AMBIENT OPERATING TEMPERATURE

+36 to +120 degrees Fahrenheit  
(+2 to +49 degrees Celsius)

### ELECTRICAL POWER CONFIGURATIONS

100 to 120 Volts AC, 50/60 Hz, 0.50 Amperes maximum.  
200 to 240 Volts AC, 50/60 Hz, 0.25 Amperes maximum.  
Applications over 240 Volts AC require optional transformer(s).  
24 Volts AC, 2 Amperes maximum.

## COMPONENTS

### FUSES

One located on the printed circuit board.  
Type AGC, 250 Volts, fast blow, 2 Amperes.

### PUMPS

Peristaltic, dual roller, self-priming and self-checking.  
115, 208 or 230 Volts AC.  
Inlet vacuum .....8 inches of mercury  
Detergent outlet pressure .....5 pounds per square inch  
Rinse outlet pressure .....30 pounds per square inch  
Tubing material .....Silicone  
Fluid at one centipoise.

### Speed & Displacement

#### DETERGENT PUMP - (3/16 ID TUBE)

Standard - 100 rpm .....5 oz per min  
.....148 ml per min

#### RINSE PUMP - (1/16 ID TUBE)

Adjustable 20 to 100 rpm .....0.05 to 0.88 oz per min  
.....1.6 to 26 ml per min

SPECIFICATIONS

**Hydraulic Performance**

**DETERGENT PUMP**

Maximum vacuum ----- 20 inches of Mercury [Hg]

Maximum pressure ----- 20 pounds per square inch

**RINSE PUMP**

Maximum pressure ----- 40 pounds per square inch

**CONDUCTIVITY PROBE INPUT MEASUREMENT RANGE**

660 to 12,800 micromhos when using 0.4 constant (K factor) probes.

**LOW DETERGENT ALARM**

An adjustable, audible alarm.

The indicator lamp on the front panel flashes approximately 2 times per second when the alarm sounds. See the **Operation** section of this manual.

**AUTOMATIC TIMEOUT ALARM**

Sounds if setpoint cannot be reached in 24 seconds.

**NOTE**

Design and specifications are subject to change without notice.

# INSTALLATION & SETUP PROCEDURES

## PHYSICAL INSTALLATION

### ⚠ CAUTION: SAFETY

- Refer installation and service to qualified personnel only.
- Installation must comply with all applicable plumbing & electrical codes.

### 1. MOUNTING THE UNIT

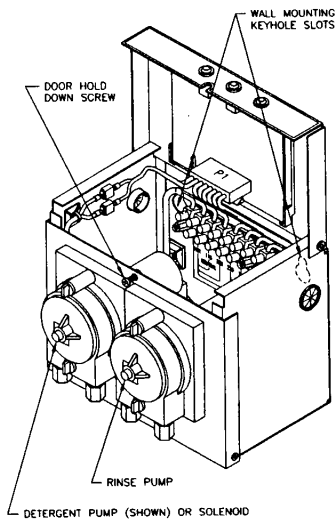

Carefully select a place to mount the unit. Remember that there must be room around the unit for access to switches, wires and tubing, and to swing the top door open for both installation and maintenance. The unit is normally mounted against a stable vertical surface with the pumps side-by-side and their tube openings at the bottom. Avoid steam and other sources of moisture, such as from spray or splash. Do not subject the unit to temperatures outside the range +36° to +120° F (+2° to +49° C).

You may accomplish wall mounting using the two keyhole slots on the interior back panel. Wall anchors and mounting screws are provided in the installation kit. No mounting template is required. A mounting bracket kit is available for dishwasher top mounting applications (see **Recommended Spare Parts & Accessories**).

The circuit board door is held closed by a captive hold down screw that fits through a slot in the door. The pump door is held closed by the circuit board door. There are no user serviceable parts that are accessible without proper tools.

### 2. INSTALLING THE CONDUCTIVITY PROBE

If available and suitable for the application, use the washer manufacturer's pre-drilled access hole. Otherwise, punch a  $\frac{7}{8}$  inch (2.2 cm) hole through the wash tank in a location that will provide accurate sampling of the detergent solution. Typically, you would mount the probe about 4 inches (10 cm) above the bottom of the tank, away from any heater elements, corners or any mechanical parts (such as water level floats). Smooth the edges so gaskets will seal well, and mount the probe.

### 3. INSTALLING THE DETERGENT BULKHEAD FITTING

Punch a hole in the wash tank in a suitable location above the water level line. See **Appendix C**. For best results, mount the fitting directly above the point where the probe is located. All necessary installation parts for a typical installation are included in the installation kit supplied with the NS-2000, or with the powder/solid detergent hopper.

#### 4. CONNECTING CHEMICAL SUPPLY LINES

Illustrations showing installation and hookup are in **Appendix C**.

- **Detergent & Rinse Pump Input Lines**

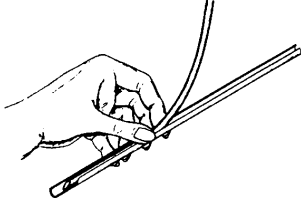

Connect the  $\frac{1}{4}$  inch (6 mm) detergent or  $\frac{1}{8}$  inch (3 mm) rinse polyflow line to the polyflow nut on the left (suction side) of the pump squeeze tube. Tighten the nuts on the fittings. Make sure the connection is airtight. Run the polyflow lines to the chemical drums, and secure the end of each supply line into its respective container. Use a snap-in standpipe for liquid detergent lines.

The snap-in standpipe is a rigid three-quarter round “u”-shaped tube section 18 inches (46 cm) long. Cut the polyflow line at a 45° angle. Press the feed end of the polyflow line into the open part of the “u”. Leave the bottom of the standpipe slightly lower than the inlet of the polyflow line.

- **Detergent Pump Output Line (Left Pump)**

Connect the  $\frac{1}{4}$  inch (6 mm) polyflow line to the polyflow nut on the right side of the detergent pump squeeze tube. Tighten the nut on the fitting. Run the feed line to the detergent bulkhead fitting (see **Appendix C**). Use as short a run of line as possible and keep the lines away from steam pipes, open flues or any other place where they may be accidentally damaged by the machine operators. In this and other output line runs, always try to avoid uphill runs. Secure the polyflow line into the fitting.

- **Rinse Pump Output Line (Right Pump)**

Connect the  $\frac{1}{8}$  inch (3 mm) polyflow line to the polyflow nut on the rinse pump squeeze tube. Tighten the nut on the fitting. Run the feed line to the plastic injector/check valve fitting. Follow the instructions included in the installation kit.

#### IMPORTANT OPERATING NOTE

Although the rinse pump is capable of pumping against 40 pounds of pressure per square inch (2.8 Kg psc), it is not advisable to operate at this level. The rinse pump tubing life will be severely shortened. Most dishwasher manufacturers specify no more than 25 psi (1.8 Kg psc) in the washer rinse line, and the water pressure should always be below this specification to ensure optimum performance and results.

## 5. PLUMBING CONNECTIONS TO WATER SOLENOID

Solenoids are used to supply water to a powder or solid detergent hopper. The compression fittings on the solenoid inlet and outlet accept either  $\frac{1}{4}$  inch (6 mm) polyflow plastic line or  $\frac{1}{4}$  inch (6 mm) copper pipe (not supplied with unit). Follow the flow arrows on the solenoid when making connections. Consult the instructions supplied with the detergent hopper. Regulate water pressure to the hopper in the range from 20 to 30 psi (1.4 to 2.1 Kg psc).

### NOTE

If using the optional pressure switch, consult the instructions in the installation kit.

## ELECTRICAL CONNECTIONS

### ⚠ CAUTION

- Dangerous voltages are wired into this unit and are present in the cabinet even when the power switch is set to off.
- Refer installation and service to qualified personnel only. Installation must comply with all applicable electrical codes.

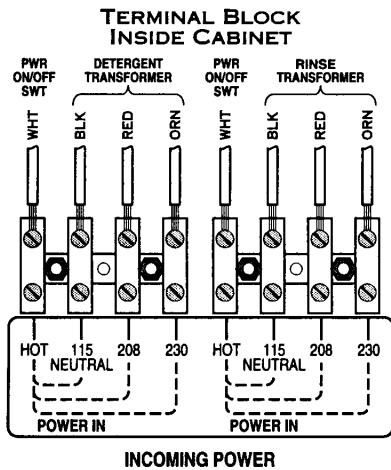

Locate electrical circuits on the dishwasher that provide power as described in the **Specifications** section of this manual. Power must be supplied to the NS-2000 only when the dishwasher is in operation and must be turned off when the dishwasher is off. Connect the two legs of each power source to their appropriate terminals inside the cabinet, as detailed on the power wiring label inside the cabinet. Always connect a ground wire from the ground lug provided in the NS-2000 cabinet to the ground at the washer power source.

### NOTE

The terminal block diagram shows a dual transformer configuration. When using only one transformer, only the four left (detergent) terminals are used.

For an NS-2000 with a pressure switch, connect to a power source which is on during the entire wash/rinse cycle to the detergent side (left side) of the terminal block.

For an NS-2000 without a pressure switch, connect the power from the washer rinse solenoid to the detergent side (left side) of the terminal block.

There are 24 volt versions of the NS-2000 available without an internal transformer. These should also be wired through the terminal block. The wiring label indicates the detergent and rinse power positions.

### NOTE

Rinse power — For installations with internal boilers (calorifiers), refer to the instructions in Appendix A.

## PROBE CONNECTIONS

There are connections for either a standard probe or a temperature compensated probe. You must bring the probe's wires into the unit through the access hole in the side, then route the wires across the bottom and through the triangular pump door cutout to the circuit board connector. This protects the wires from being scraped by the high voltage shield when the pump door is opened or closed.

## EXTERNAL CONTROLS DESCRIPTION

### Power ON/OFF Switch

This double-pole single-throw switch provides control over the incoming power to the NS-2000. It accommodates one or two transformers.

### Detergent Prime Switch

There must be power to the NS-2000 for this switch to work. The detergent pump runs as long as this switch is depressed when in the probe mode. In the probeless mode, the switch need only be pushed to start an initial feed cycle.

### Rinse Prime Switch

There must be power to the NS-2000 for this switch to work. The rinse pump runs as long as this switch is held depressed.

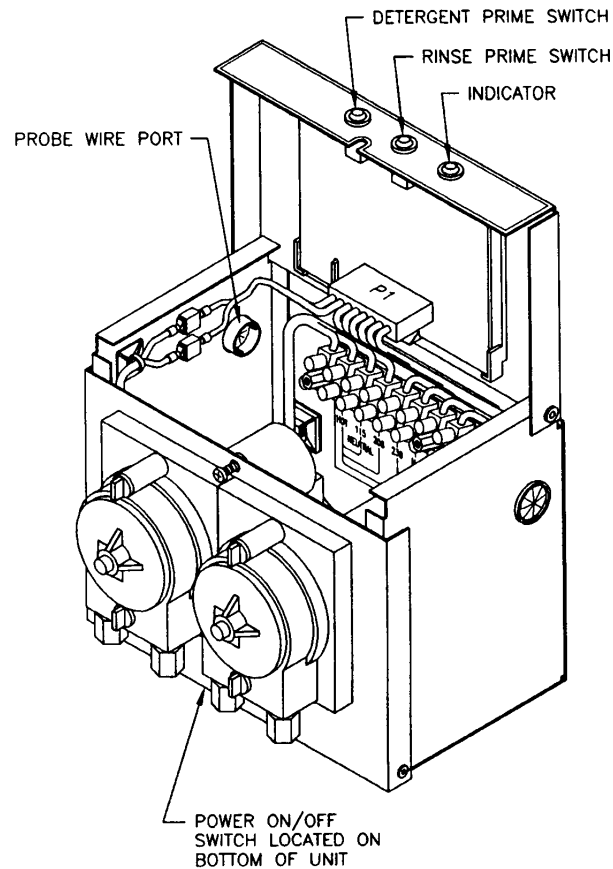

## INTERNAL CONTROLS DESCRIPTION

### INTERNAL CONTROLS DIAGRAM

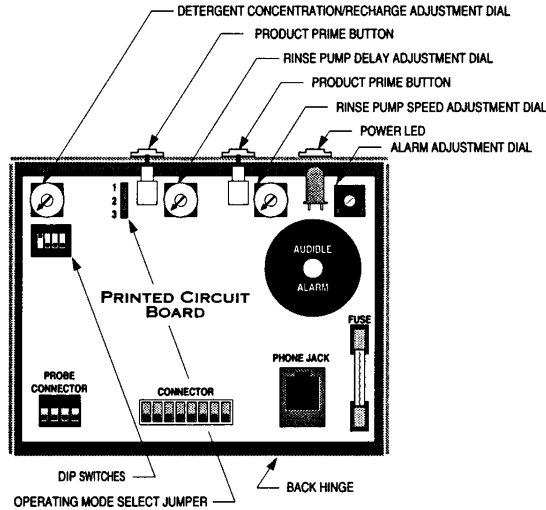

### DETERGENT CONTROL

#### Operating Mode Select Jumper

Position 1 & 2 for Standard Probe and Probeless operation.

Position 2 & 3 for XT2 Probeless operation.

#### Quad Control DIP Switches

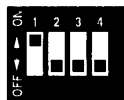

Switch 1 - Mode Select

- On for probe.
- Off for probeless.

#### Probe Operation

Switch 2 - Detergent Concentration Range Select

- On for high range (2,900 to 12,800 micromhos).
- Off for low range (640 to 2,900 micromhos).

Switch 3 - Overfeed Stop Select

- On to enable stop (detergent feed stops after 3 minutes).
- Off to disable stop.

Switch 4 - Reduced Detergent Injection Rate Select

- On for a 50% rate (4 seconds on & 4 seconds off).
- Off for a 25% rate (1 second on & 3 seconds off).

#### Standard Probeless Operation

Switch 2, 3 & 4 - Initial Charge Select

Switch combinations give an initial charge time.

Range - 0 to 20 times the recharge time.

**XT2 Probeless Operation**

DIP switch not used.

**Detergent Concentration/Recharge Adjustment Dial  
With Probe**



- This dial setting determines the detergent concentration setpoint.
- Low Range - 640 to 2,900 micromhos.
- High Range - 2,900 to 12,800 micromhos.

**Standard and XT2 Probeless**

- This dial setting determines the length of time the detergent pump will be on when power is applied (recharge time).
- Range - 0 to 16 seconds.

**Alarm Adjustment Dial (Probe Operation Only)**



- This dial is used to increase or decrease the sound level of the alarm.
- Range - Off to 93 dB.

**RINSE CONTROL**

**Rinse Pump Speed Adjustment Dial**



**Standard Probeless Operation**

This dial adjusts the rinse pump's flow rate.

Range - 0.05 to 0.88 oz per minute.

1.6 to 26 ml per minute.

**XT2 Probeless Operation**

Range - 0 to 27 seconds.

Flow Rate - 0.88 oz per minute (26 ml/minute).

**Rinse Pump Delay Adjustment Dial**

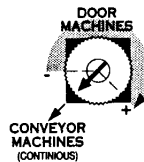

**Standard Probeless Operation**

This dial sets the rinse pump delay after the rinse signal is received.

- Conveyor Range - No delay.
- Door Range - 0 to 10 second delay.  
15 seconds fixed run time.

**XT2 Probeless Operation**

No delay. Pump starts when rinse power is received.

## SETUP PROCEDURES

### DETERGENT SYSTEM WITH PROBE

Set DIP switch 1 to ON.

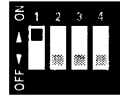

### Concentration Adjustment

#### PRESET METHOD

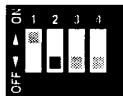

1. Set concentration range with DIP switch 2 (up for high range and down for low range) and the Detergent Concentration/Recharge Adjustment dial. Use similar washer experience if available or start with low range and the dial at a minimum setting (counter-clockwise).
2. Fill the wash tank with water and make sure that the water is heated to the correct wash temperature.
3. Turn on the wash motor to agitate the solution. Turn on the NS-2000 unit and allow the detergent to feed until it stops.
4. Check the concentration and adjust if necessary (see Step 1) to correct for differences between the actual and desired concentration.
5. Re-run the test as necessary to perfect the concentration.

#### PRECHARGED WASH TANK METHOD

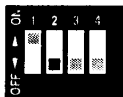

1. Set DIP switch 2 to the appropriate range for the product being used. Powder and high concentration product are normally used in the high range (switch up), and liquid detergents tend to be in the low range (switch down) of detergent concentration. Begin with the Detergent Concentration/Recharge Adjustment dial fully counter-clockwise (minimum setting).
2. Fill the wash tank with fresh water, and make sure that the water is heated to the correct wash temperature.
3. Manually add to the wash tank the amount of detergent that your calculations show will provide optimum results.
4. Turn on the washer to agitate the solution.
5. Measure the detergent concentration using any of the standard methods (pH, titration, etc.). Manually add detergent, or dilute the wash tank water, until the desired concentration is reached.
6. Slowly increase the Detergent Concentration/Recharge Adjustment dial (turn clockwise) until the detergent pump just turns on, or the solenoid clicks. Set the dial back slightly until the feed stops.

#### LOW DETERGENT ALARM TEST

Delay is fixed and is not adjustable.

1. To check and/or set the alarm, remove the detergent suction (input) line from the chemical supply container.
2. Run the pump until the wash tank feed line is empty. The alarm should turn on after a delay of 24 seconds if the wash tank detergent concentration setpoint has not been reached. Refer to the **Operation** section of this manual.

3. Reinsert the input line into the chemical source and run the pump until the wash tank feed line is full. The alarm may turn off while chemical is being fed if the wash tank concentration is increasing.

**OVER FEED STOP/STOP DEFEAT**

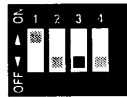

OVERFEED STOP DEFEATED (3-OFF)

1. When DIP switch 3 is set to ON, the detergent feed will be completely stopped whenever it runs for more than 3 minutes without reaching the detergent concentration setpoint.

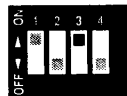

OVERFEED STOP SELECTED (3-ON)

2. You may test this by repeating the low detergent alarm test described above. The pump will stop after 180 seconds. Refer to the **Operation** section of this manual.

3. In any case, where an extended feed time is normal, DIP switch 3 should be set to OFF, thus defeating the Overfeed Stop function and allowing the detergent pump to continue to feed.

**REDUCED DETERGENT INJECTION RATE**



25% REDUCED RATE SELECTED (4-OFF)

The injection rate controls the time for the conductivity to change. Set DIP switch 4 to a faster or slower injection rate that fits the needs of the installation: ON is a 50% rate (4 seconds on and 4 seconds off), and OFF is a 25% rate (1 second on and 3 seconds off).



50% REDUCED RATE SELECTED (4-ON)

**DETERGENT SYSTEM - STANDARD PROBELESS**

Set DIP switch 1 to OFF.

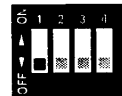

**Concentration Adjustments**

**RECHARGE TIME**



CLOCKWISE INCREASES

In standard probeless mode, the amount of time the detergent pump is on for recharge is a timed function, which you may set by adjusting the Detergent Concentration/Recharge Adjustment dial. The possible range is zero (dial fully counter-clockwise) to 16 seconds (dial fully clockwise).

1. Preset the Detergent Concentration/Recharge Adjustment dial to the approximate time value desired, and fill the wash tank with water heated to the correct wash temperature.
2. Turn on the washer for no longer than 20 seconds to dispense the recharge amount of detergent and agitate the solution.
3. Check the concentration. If necessary, adjust the dial to correct for differences between actual and desired concentration.
4. Rerun the test as necessary to perfect the concentration.

**INITIAL CHARGE TIME**

An automatic initial charge of detergent is triggered by the extended presence of the power signal (longer than 20 seconds). You may set the length

of this initial charge as a multiple of the recharge time, using DIP switches 2, 3, and 4. Possible multiples are: 0x, 1x, 3x, 5x, 8x, 12x, 15x and 20x.

For example, if you set the Detergent Concentration/Recharge Adjustment dial to 4 seconds and the multiple to 5x, the initial charge is 20 seconds (5 times 4 seconds). You may thus set initial charge in the range from zero seconds (multiple at 0x) to 320 seconds—5 minutes & 20 seconds—(multiple at 20x and Detergent Concentration/Recharge Adjustment dial at 16 seconds).

1. Set the Detergent Concentration/Recharge Adjustment dial.
2. Set the multiple using DIP switches 2, 3 and 4 according to the following:

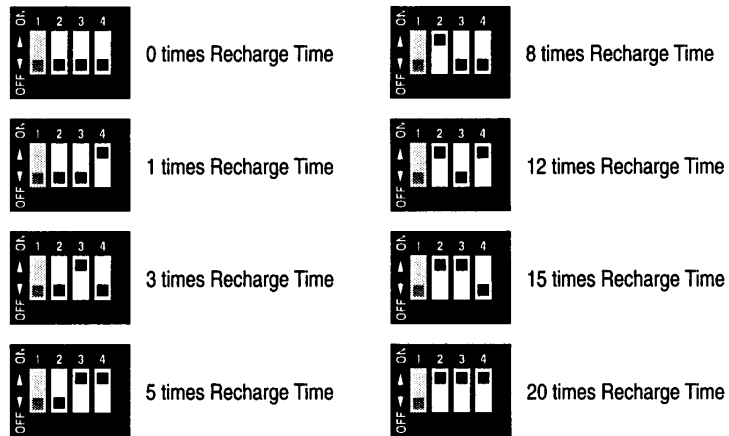

## DETERGENT SYSTEM - XT2 PROBELESS

### Concentration Adjustments

#### RECHARGE TIME



In XT2 probeless mode, the amount of time the detergent pump is on for recharge is established using the Detergent Concentration Recharge/Adjustment dial. The possible range is zero (dial fully counter-clockwise) to 16 seconds (dial fully clockwise).

1. Preset the Detergent Concentration/Recharge Adjustment dial to the approximate time value desired, and fill the wash tank with water heated to the correct wash temperature.
2. Turn on the washer for no longer than 20 seconds to dispense the recharge amount of detergent and agitate the solution.
3. Check the concentration. If necessary, adjust the dial to correct for differences between actual and desired concentration.
4. Rerun the test as necessary to perfect the concentration.

**INITIAL CHARGE TIME**



An automatic initial charge of detergent is triggered by the extended presence of the power signal (longer than 20 seconds). You may set the length of this initial charge using the Rinse Pump Delay Adjustment dial in the range from zero to 108 seconds.

**RINSE SYSTEM (PROBE & STANDARD PROBELESS)**

The length of the rinse pump operation is determined by the type of washer. In a conveyor type washer, the rinse pump runs as long as rinse power is applied. In a door type washer, the rinse pump runs a maximum of 15 seconds after the delay time and for as long as the washer rinse signal remains on.

**Rinse Delay Time**

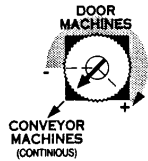

Set the Rinse Delay Adjustment dial according to the type of washer (conveyor or door) being used.

- On conveyor machines, set this dial fully counter-clockwise (no delay).
- On door machines, adjust the dial clockwise for a delay that will ensure the desired application of rinse aid in the wash cycle. Minimum delay is at 9:00 o'clock. Range is 0 (zero) to 10 seconds.

**Flow Rate Adjustment**



Adjust the Rinse Speed Adjustment dial to control the pump speed to minimize streaking on the ware. The pump will run at the selected speed after the delay while the rinse power signal is present for a maximum of 15 seconds. In the case of units with internal calorifiers, see **Appendix A**.

**RINSE SYSTEM (XT2 PROBELESS)**

No delay. The rinse pump starts when rinse power is applied.

**Run Time Adjustment**



Use the Rinse Pump Speed Adjustment dial to set the time (0 to 27 seconds) to deliver the required amount of rinse chemical.

## OPERATION

### ALARM & INDICATOR

The internal audible alarm and the indicator lamp on the front panel together provide the following operating status information:

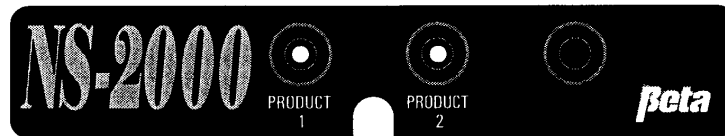

- Power from washer .....Indicator on continuously
- Detergent or rinse feeding.....Indicator flashing slowly
- Rinse delay .....Indicator flashing rapidly (Standard Probeless operation)
- Detergent low.....Indicator flashing rapidly and alarm pulsing (Probe operation only)
- Overfeed (Probe Operation Only)**
- Stop.....Indicator and alarm on continuously
  - Stop Defeat .....Indicator flashing rapidly and alarm pulsing

# MAINTENANCE

## 1. PERIODIC MAINTENANCE

### 1.1 PUMP & SQUEEZE TUBE REPLACEMENT SCHEDULE

Since every installation is different (chemicals, tube runs, operating frequency, etc.), an exact tube replacement schedule cannot be specified. With use the tube slowly evolves from round to oval, and the amount of chemical pumped decreases. By regularly checking the amount of chemical pumped, you can determine general tube life. It is recommended that you closely monitor the time it takes the original tube to reach the end of its flex life, and then establish a replacement schedule. Replacing tubes at regularly scheduled intervals ensures more accurate product use and reduces service calls. In general short feed lines of a large diameter will improve pump tube life.

#### NOTE

It is very important not to let the tubes become worn to the point where they tear and allow chemicals to saturate the pump housing.

### 1.2 HOW TO REPLACE PUMP CARTRIDGES AND SQUEEZE TUBES

Only the cartridge replacement should be done in the field. Tube replacement can be accomplished later. See the Pump Assembly exploded view drawing in **Appendix D**. Note that each pump has a different size squeeze tube and polyflow nuts.

- Detergent Pump ..... 3/16 inch tube ID ..... 1/4 inch nuts
- Rinse Pump ..... 1/16 inch tube ID ..... 1/8 inch nuts

#### 1.2.1 To Remove

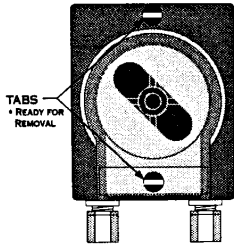

- Turn off power to the unit.
- Remove the pump from the motor housing by twisting the two quarter turn fasteners at top and bottom (rotate the tabs 90° to horizontal).
- Remove the old pump from the motor housing.
- Remove the supply and feed lines from the old pump and connect them to the new pump.

### 1.2.2 To Install

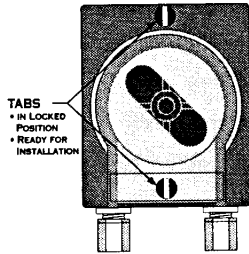

- a. Install the new pump as follows:
  - Turn the tabs to vertical.
  - Mesh the pump drive spline with the motor gear (rotate pump until it engages).
  - Hold the pump in the vertical position.
- b. Press the tabs into the motor housing until you hear a distinct click.
- c. Turn on power to the unit.

## 1.3 HOW TO REPLACE PUMP MOTOR & SOLENOID SUBASSEMBLIES

### 1.3.1 To Remove

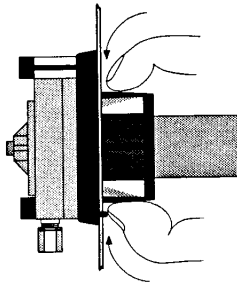

- a. Turn off power to the washer.
- b. Remove the supply and feed lines from the old pump motor/solenoid and connect them to the new pump motor/solenoid.
- c. Remove the quick disconnect tabs from the electrical connections at the back of the pump motor/solenoid. Take care to keep the pump wire pairs together.
- d. Two flexible ears hold the pump motor/solenoid assembly in the cabinet. To remove the pump motor/solenoid, compress the two ears sufficiently to allow it to slide out through the hole in the cabinet.

### 1.3.2 To Replace

- a. Place the alignment tip of the pump motor/solenoid housing in the down position.
- b. Slide the pump motor/solenoid housing into the cabinet hole. The holding ears will be compressed by the sheet metal, then will expand to hold the pump motor/solenoid in place. Verify that both ears popped out and are locked in place.
- c. Reinstall the quick disconnect tabs on the electrical connections at the back of the pump motor/solenoid. Turn on power. Use the Prime button to verify the proper pump rotation (clockwise). Reposition the motor wires if necessary to change direction.

## 1.4 CLEANING THE PROBE

You must clean the conductivity probe tips (electrodes) on a regular basis to ensure control accuracy. The water conditions (e.g., water hardness) and the type of soil load are the primary factors in determining a cleaning schedule.

## 2. TROUBLESHOOTING

Refer to the exploded assembly drawings, item lists, and the complete unit wiring diagram in **Appendix D**, and the circuit board illustration in the **Internal Controls Description**. To order items from the drawings, find the item on the drawing and note its sequence number, locate it in the item list using the sequence number, and order using the item number.

### 2.1 NO POWER

2.1.1 Is the On/Off switch on?

2.1.2 Is proper line power voltage connected to the power input terminals in the unit? Check both transformers. Is a circuit board fuse blown?

2.1.3 With the power wiring harness unplugged from the circuit board, is 24 volts AC measured across the transformer secondary wires when power is supplied from the washer? If not, replace the transformer. If yes, replace the circuit board.

### 2.2 PROPERLY RATED FUSE BLOWS REPEATEDLY

2.2.1 Is there a mechanical problem with a motor or solenoid (e.g., jammed tubing or frozen gears in the gearbox)?

2.2.2 Do motor and/or solenoid resistance measurements fall in the approximate range from 4 to 100 ohms? If yes, go on to the next step. If no, replace suspect part(s) since a shorted motor or solenoid will cause the fuse to blow.

#### NOTE

Measure resistance only when the power is turned off. A short will typically measure less than 0.2 ohms; an open will typically measure more than 2000 ohms.

2.2.3 Are proper voltages measured across the appropriate output terminals (i.e., detergent drive and rinse drive) when power is applied? If not, replace the circuit board. Maximum voltage is 33 to 34 VDC (without load). Rinse voltages may be lower depending on the speed setting.

### 2.2 DETERGENT FEEDS TOO OFTEN (TOO MUCH DETERGENT USED)

#### 2.2.1 With Probe

- a. Is the concentration setting correct, or is the actual concentration value close enough to the setpoint to keep the alarm from sounding? Are the probe electrodes clean?
- b. Is a dishwasher problem the cause? This could include: fill valve on, too much rinse tank overflow into the wash tank, leaking or open drain valve, or wash motor not running to agitate the solution.
- c. While the detergent is feeding, short the two probe wires together (down at the probe). Does the detergent feed stop? If so, see sections 2.3 and 2.4. If not, go on to the next step.

- d. Are the probe wires loose or disconnected? If not, short across the two probe wire terminals on the circuit board (instead of at the probe). This should stop the detergent feed.
- e. Replace the circuit board if either of these tests (steps c and d) does not stop the detergent feeding.

### 2.2.2 Probeless

Check the detergent control setup. (Refer to original setup records.) If wrong, correct. If OK, replace the circuit board.

## 2.3 DETERGENT DOES NOT FEED AT ALL

### 2.3.1 Probe

- a. Are the two probe wires shorted together? If so, the unit will never feed until this is corrected.
- b. Disconnect one of the wires at the probe to cause an open circuit. The indicator should flash slowly, indicating feeding, and the pump or solenoid should function. If so, see section 2.4. If not, go on to the next step.
- c. Disconnect one of the probe wires from the circuit board. If the detergent does not feed (or there is no voltage output from detergent drive), replace the circuit board.
- d. Before replacing the circuit board, measure the voltage from the transformer secondary wires to ground. Approximately 14 volts AC should be present. A transformer short to ground could cause the pump motor to run erratically.

### 2.3.2 Probeless

Check the detergent control setup. (Refer to original setup records.) If wrong, correct. If OK, replace the circuit board.

## 2.4 CHECKING THE DETERGENT SYSTEM FUNCTIONS

### IMPORTANT NOTE

You may use this test to verify proper functioning of all of the detergent system—probe input circuitry, detergent drive circuitry, and the low detergent and overfeed alarm.

### 2.4.1 With Probe

- a. Set the DIP switches as follows: 1 to ON; 2 to ON (high range); 3 to ON (Overfeed Stop enabled); and 4 to ON (50% reduced rate). Rotate the Detergent Concentration/Recharge Adjustment dial fully counter-clockwise (minimum).
- b. Connect a forty-seven (47) ohm  $\frac{1}{4}$  or  $\frac{1}{2}$  watt resistor across the two circuit board probe terminals, or at the end of the probe wires.
- c. Turn power on to the unit. Observe that the detergent pump or solenoid is not feeding.
- d. Slowly increase the Detergent Concentration/Recharge Adjustment dial until the detergent pump runs or solenoid clicks.

- e. Verify that the reduced feed function causes the detergent pump to start and stop (approximately 4 seconds on, 4 seconds off).
- f. Note the low detergent alarm does not sound. Rotate the Detergent Concentration/Recharge Adjustment dial fully clockwise. The detergent pump should run continuously.
- g. Wait for about 24 seconds (after continuous feed starts) until the low detergent alarm sounds.
- h. Wait for 3 minutes until the unit goes into overfeed stop and the overfeed alarm sounds.
- i. Slowly rotate the Detergent Concentration/Recharge Adjustment dial counter-clockwise until the detergent feed stops and any detergent alarm that was sounding stops.
- j. Test completed. If the test does not perform as described, replace the circuit board.

#### **2.4.2 Standard Probeless**

- a. Set the DIP switches as follows: 1 to OFF; 2, 3 and 4 to the ON/OFF combination for the desired initial charge multiple (for purposes of this explanation, 3x is used: switch 3 ON, switches 2 & 4 OFF). Rotate the Detergent Concentration/Recharge Adjustment dial to its mid-position, straight up and down for a recharge time of approximately 8 seconds.
- b. Turn power on to the unit. Observe that the detergent pump runs or solenoid clicks on, feeds for 8 seconds, and stops.
- c. Observe that 20 seconds after initial power was applied, the detergent pump or solenoid turns on again and feeds for approximately 24 seconds (3 times the recharge) and then stops.
- e. Test completed. If the test does not perform as described, replace the circuit board.

### **2.5 RINSE PUMP WILL PRIME BUT NOT FEED**

2.5.1 Is washer rinse line solenoid opening?

2.5.2 Adjust the feed rate setting on the circuit board to a rate near mid-range.

2.5.3 With the rinse power on from the washer, short across the pressure switch contact. The pump should run at the programmed speed. If not, replace the circuit board.

### **2.6 RINSE PUMP WILL FEED BUT NOT PRIME**

2.6.1 Washer must be in wash/rinse cycle to prime pump.

2.6.2 Replace the circuit board.

## **2.7 RINSE PUMP WILL NEITHER PRIME NOR FEED**

- 2.7.1 Washer must be in wash/rinse cycle to prime pump.
- 2.7.2 Does the front panel indicator lamp illuminate when the pressure switch contacts are shorted? If not, replace the circuit board.
- 2.7.3 When you push the Rinse Prime button, 33 to 34 volts DC should be measured across the motor terminals. When shorting the pressure switch contacts, 0 to 34 volts DC should be measured, depending on what pump speed setting has been selected. This voltage will change as you increase or decrease the pump speed setting.
- 2.7.4 If voltage in the proper range is present and the pump will still not run, remove the pump cartridge and observe the drive spline while you push the Rinse Prime button. If the drive spline does not turn, replace the motor assembly.

## **2.8 RINSE PUMP FEEDS CONTINUOUSLY (PROBE AND STANDARD PROBELESS)**

- 2.8.1 Is the Rinse Delay Adjustment dial set close to the Conveyor Machine position (fully counter-clockwise)? If so, increase the delay time. If not, continue to the next check.
- 2.8.2 If there is a pressure switch, disconnect one of the wires from the pressure switch. If the motor stops, check to make sure the rinse line solenoid is not on. Also, ensure that there is not a crimp in the pressure line that may hold enough pressure in the line to keep the switch on. Replace the pressure switch after satisfying those two checks. If you cannot control the speed of the motor and it continues to run with the pressure and prime switches disconnected, replace the circuit board.

## **2.9 PUMP WILL NOT PULL THE CHEMICAL OUT OF THE DRUM**

- 2.9.1 Too much vacuum created. The supply line in the chemical drum may be up against either the side or bottom, the supply lines may be too long for a viscous product, or there may be a crimp in the intake supply line, thus exceeding the pump's vacuum specifications .
- 2.9.2 There may be an air leak somewhere in the input supply line. Most often this is caused by inadequate sealing of the supply line into the squeeze polyflow nuts.
- 2.9.3 Squeeze tube is worn and the rollers can no longer squeeze the tube properly. Correct by changing the pump cartridge with the correct size squeeze tube and polyflow nuts for the chemical being pumped.

## RECOMMENDED SPARE PARTS & ACCESSORIES

This Parts and Accessories list provides a quick reference source for ordering spare or replacement parts. It also lists accessory items that may be needed that are not on the detailed assembly drawings. To order parts from the listings or drawings, find the part's sequence number (the number in the bubble in the drawing), use that to find the item number, and order by item number.

### SPARE PARTS

<u>ITEM DESCRIPTION</u>	<u>ITEM #</u>
Printed Circuit Board .....	057132
Tube, Detergent, 3/16" ID .....	037617
Tube, Rinse 1/16" ID .....	037616
Tube Insert, Detergent, 1/4T .....	036969
Tube Insert, Rinse, 1/8T .....	036982
Tube Fitting, Nut, Detergent, 1/4T .....	043823
Tube Fitting, Nut, Rinse, 1/8T .....	017458
Pump Cartridge, Detergent, 1/4 .....	039556
Pump Cartridge, Rinse, 1/8 .....	039549
Pump Roller Assembly .....	039550
Quarter turn Pin for Small Pump .....	051160
Pump Motor Gearbox .....	051120
Solenoid Assembly .....	050014
Transformer, 120/208/240 VAC - 24 VAC, 40 W, 50 Hz .....	050562
Fuse (AGC 250 Volt 1 Amp) .....	042881
Dummy Cover .....	051606

### ACCESSORY KITS

Pressure Switch Kit .....	051599
Standard Conductivity Probe Kit .....	035590
Mounting Bracket Kit .....	018224
Concentration Probe With Temperature Sensor .....	018163

## TECHNICAL ASSISTANCE

If you require technical assistance or additional product technical information contact the appropriate Technical Support Department. See **Preface** for company information and telephone numbers.

## PRODUCT REPAIR

If you need to return an item for repair you must call or write to obtain an "RPR" number **before** you may return the product. The Repair Department will issue a unique Return Product Request (RPR) number for any product that satisfies the Warranty requirements. Multiple items in a single shipment will not normally require multiple RPR numbers, but always make sure that the Repair Department knows the entire extent of your shipment in case this general rule doesn't apply. Refer to this number in all your documentation, prominently display it on the outside of the shipping container, and refer to it if you need to call for information about the status of the repair.

It is very helpful to the Repair Department if you include in the shipping container a description of the problem, symptoms, failure or abnormality that precipitated the equipment's return.

Failure to obtain an authorization number before sending an item in for repair or replacement may seriously delay the repair and/or return of your equipment.

## SPECIAL NOTE

Material in this manual is subject to change without notice. Manual revisions will be made on an as needed basis. Special circumstances involving important design, operation or application information will be released via Technical Service Bulletins.

# APPENDIX

## A DISHMACHINES WITH INTERNAL CALORIFIERS (BOILERS)

### Rinse Pump Delivery (Probe or Standard Probeless)

#### NOTE

This style of installation has a built-in hot water boiler, also known as a calorifier. The rinse is injected into the boiler at the same time that the detergent is added to the warewasher.

1. For electrical installation, jumper the 24 volt Detergent input power to the rinse input power at the appropriate terminals in the unit.
2. For the rinse pump delay setup, always set the delay to 0 (zero) for door machines.
3. Set the rinse pump speed to deliver the required rinse additive volume within the 15 seconds of run time.
4. The following table shows the correlation between rinse pump speed setting and amount of rinse product pumped when the delay is set to 0.

<u>RINSE PUMP DIAL SETTING</u>	<u>TOTAL AMOUNT OF PRODUCT PUMPED</u>
7 o'clock	none
9 o'clock	1.5 ml.
11 o'clock	5.5 ml.
1 o'clock	6 ml.
3 o'clock	6 ml.
5 o'clock	6 ml.

#### Rinse Pump Installation

##### RINSE INJECTION TIMING

The rinse and detergent signal inputs on the circuit board are tied together, thus both are fed into the system at the same time. However, detergent is fed into the wash reservoir while rinse aid is fed into the boiler (water source).

## B TYPICAL INSTALLATION EXAMPLES

### Liquid Detergent Configuration

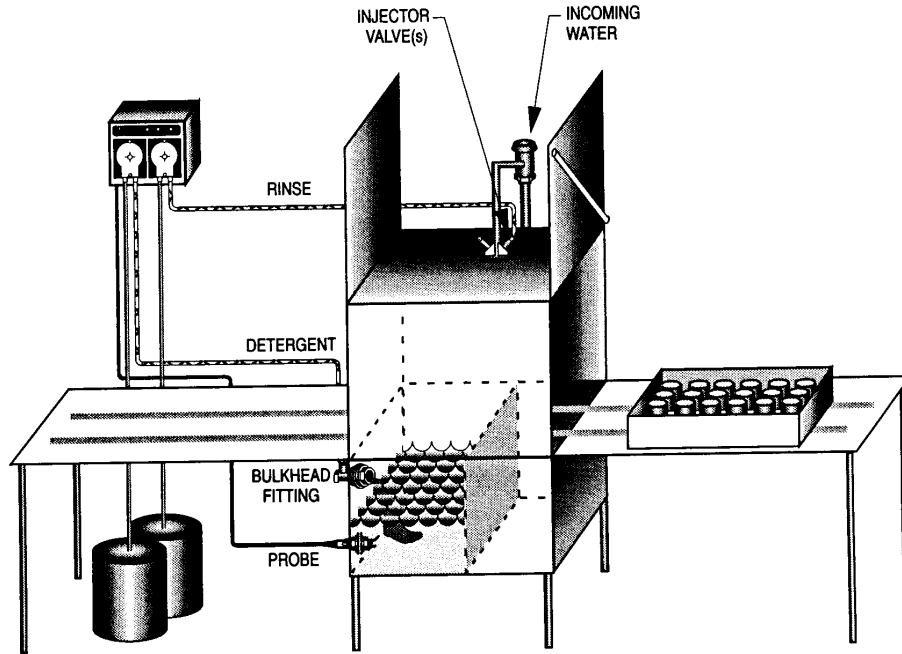

### Powder Detergent Configuration

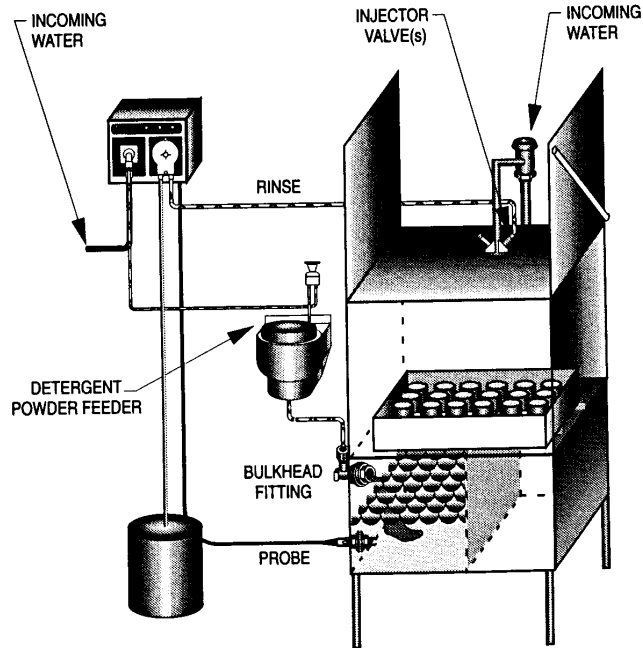

**C DIAGRAMS & DRAWINGS****SEQUENCE TO ITEM NUMBER LIST**

SEQ #	ITEM #	ITEM DESCRIPTION
1	056748	NS-2000 Base Assembly Enclosure, Stainless Steel
2	050650	NS-2000 Front Door, Stainless Steel
3	050651	NS-2000 Top Door, Stainless Steel
4	051120	Gear Motor Assembly, 5 oz. Pump
5	0051606	5 oz. Pump Dummy Cover
6	050562	Transformer, 120/208/240 VAC In, 24 VAC Out, 40 Watts Power Rating
7	051124	Terminal Block 10 mm, Screwdown Type, 8 Connections
8	041711	Terminal Block, Single Connection, Panel Ground Lug, for 8 AWG Wire
9	037598	Double Pole-Single Throw ON/OFF Panel Rocker Switch, 4 A 250 VAC Rating
10	055708	Terminal Block Label, 8 Position, Detergent/Rinse, 115 - 230 VAC
11	057132	NS-2000 Printed Circuit Board, 24 VAC
13	036983	Printed Circuit Board Holder
14	057068	NS-2000 Cover Label, 3 holes, White Print
17	039460	Boot, Switch, Santoprene, NS-2000
18	044144	Adhesive Plastic Sheet, 3.22" X 3.38"
20	036982	5 Ounce Pump Insert, 1/8"
21	036969	5 Ounce Pump Insert, 1/4"
22	017458	Tube Fitting, Nut, Vp, 1/8"
23	041155	Pop Rivet, 1/8" X 1/8"
24	041175	3/16" Diameter Hex Standoff, 4/40 X 1/2" Long
25	041088	Kep Nut, 6-32
26	040992	Phillips Pan Head Screw, 6-32 X 3/4" Long
28	041717	Crimp Terminal, 18 to 22 AWG, 1/4" Long, Male
29	041903	Tube Fitting, Nut, Vp, 1/4"
30	037616	Tubing, Norprene, 0.062" ID X 5.25" Long (Rinse )
31	037617	Tubing, Norprene, 0.188" ID X 5.25" Long (Detergent)
32	056186	NS1000 Harness: 1 Transformer, 2 Pumps, 1 Printed Circuit Board

## APPENDIX

SEQ #	ITEM #	ITEM DESCRIPTION
34	036964	Front Housing for 5 Ounce Pump
35	036965	Rear Housing for 5 Ounce Pump
36	036967	Black Delrin Spinner for 5 Ounce Pump
37	043981	White Delrin Roller, 0.496" OD
38	036980	Delrin Roller Shaft, 0.188" OD X 0.7" Long for 5 Ounce Pump
39	039455	Stainless Steel Spinner Shaft, 0.25" Diameter X 1.25" Long
40	051160	Quarter Turn Pin for 5 Ounce Pump
41	043839	Stainless Steel Phillips Pan Head Screw, #4 X 3/8" Long
42	056186	NS-2000 Harness: 1 Transformer, 2 Pumps, 1 Printed Circuit Board
43	056185	NS-2000 Harness, 24v input, 2 Pumps, 1 Printed Circuit Board
44	039734	Orange, 18 AWG Wire, 10" Long W/QDC
48	041318	Small Tie Wrap
49	041323	Backing for Tie Wrap
50	050014	NS-2000 Detergent Solenoid Assembly
51	051599	Pressure Switch Accessory Kit
52	038090	Hazard Warning Label, Disconnect Power, High Voltage
54	042035	Silicone Grease Lubricant
56	039409	Ground Screw Label
<b>SOLENOID</b>		
SEQ #	ITEM #	ITEM DESCRIPTION
1	050015	Valve Body
2	050016	Mounting Plate
3	050017	Clip
4	050171	Coil
5	038448	Diaphragm/Plunger Kit
6	039662	Filter
7	043823	Tube Nut
8	051078	Screw
9	043839	Screw

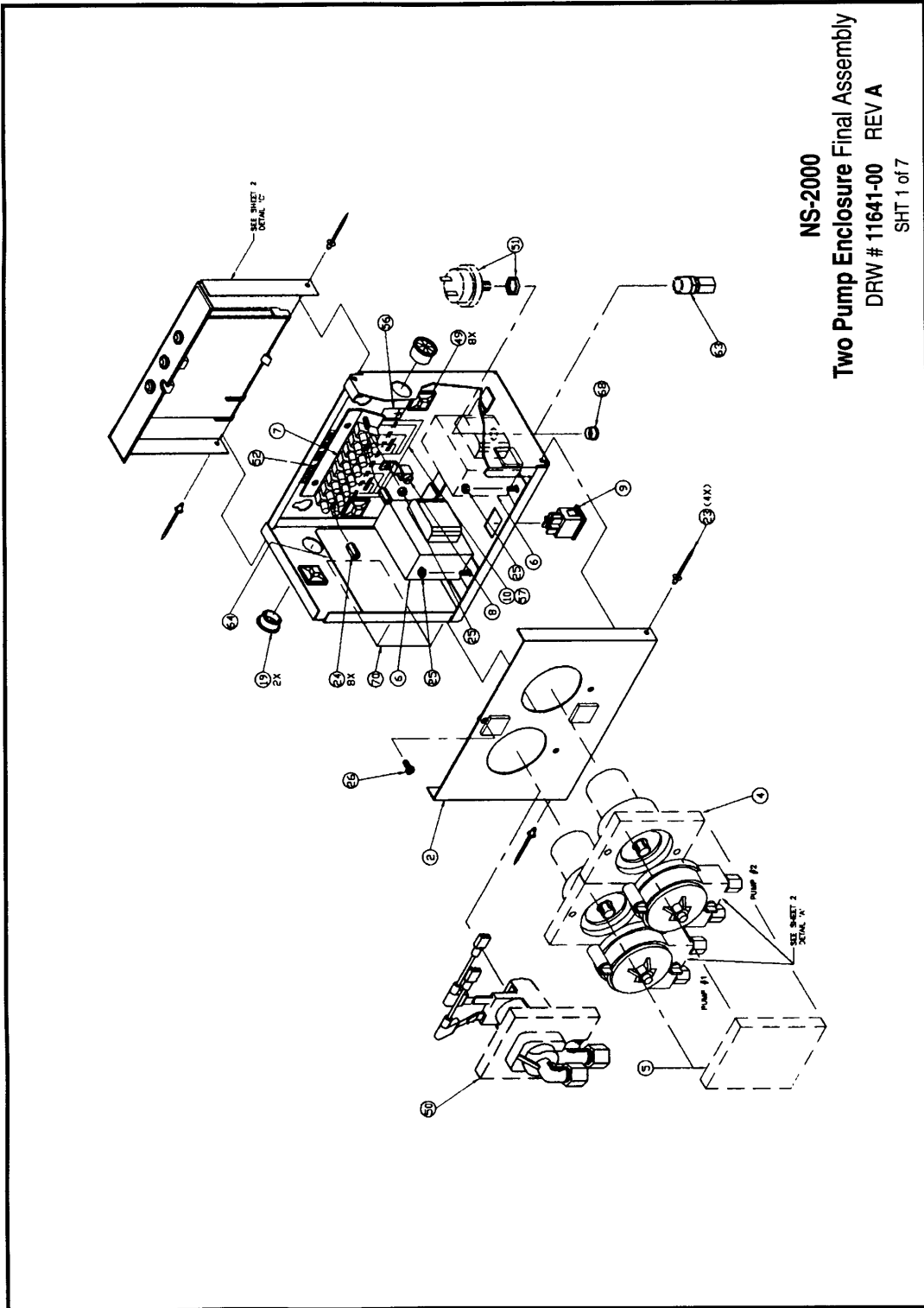

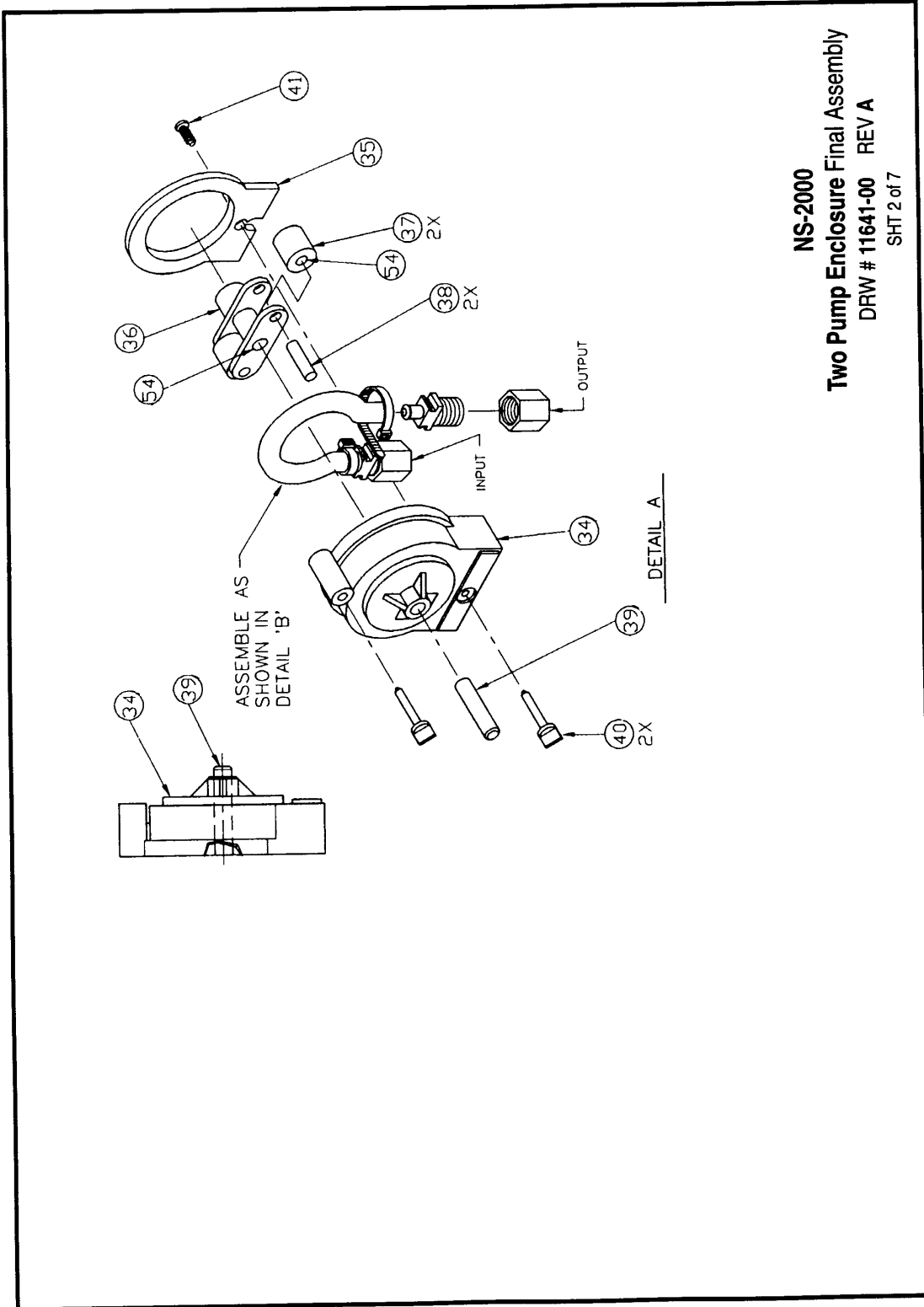

**NS-2000**  
**Two Pump Enclosure Final Assembly**  
DRW # 11641-00 REV A  
SHT 3 of 7

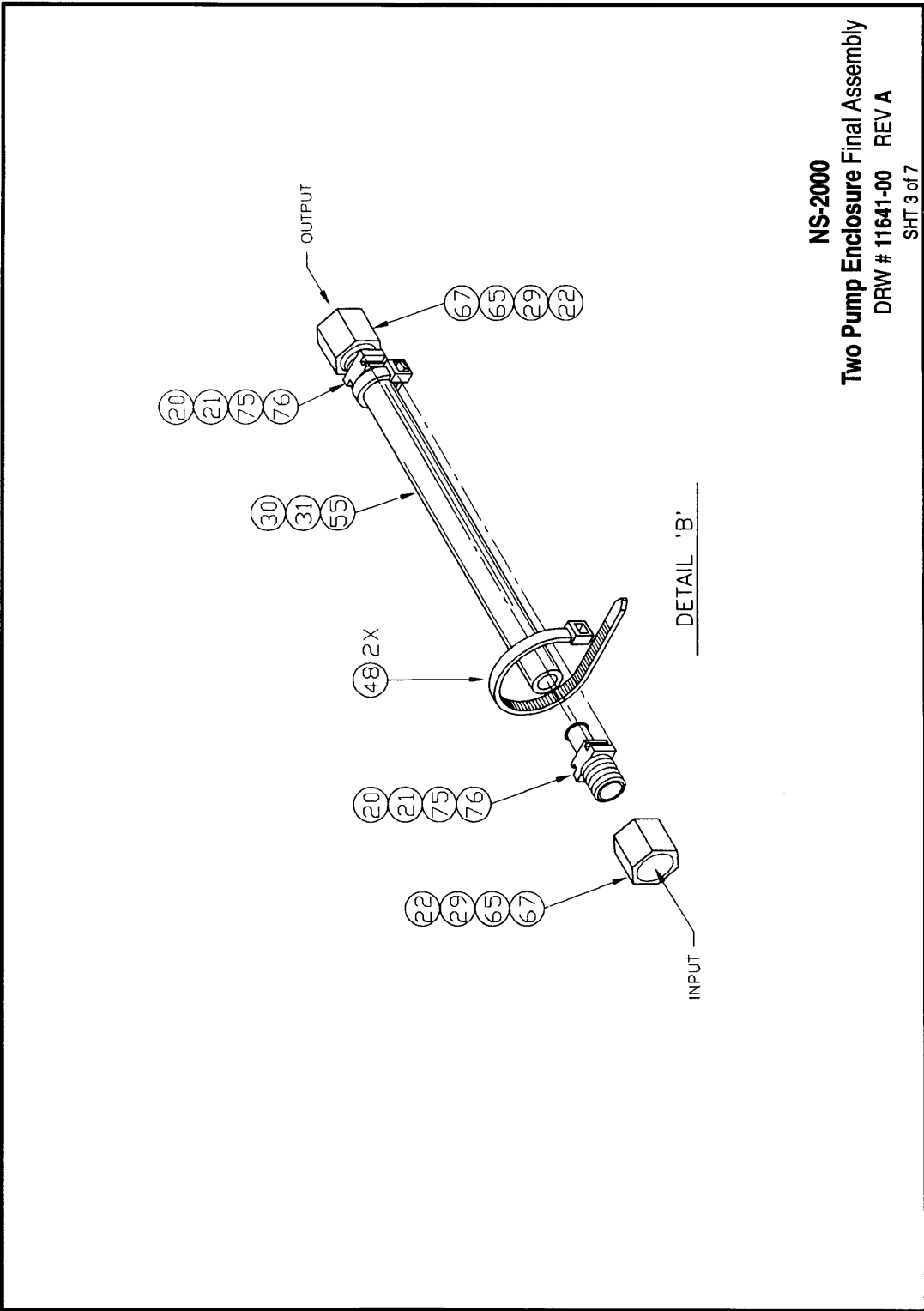

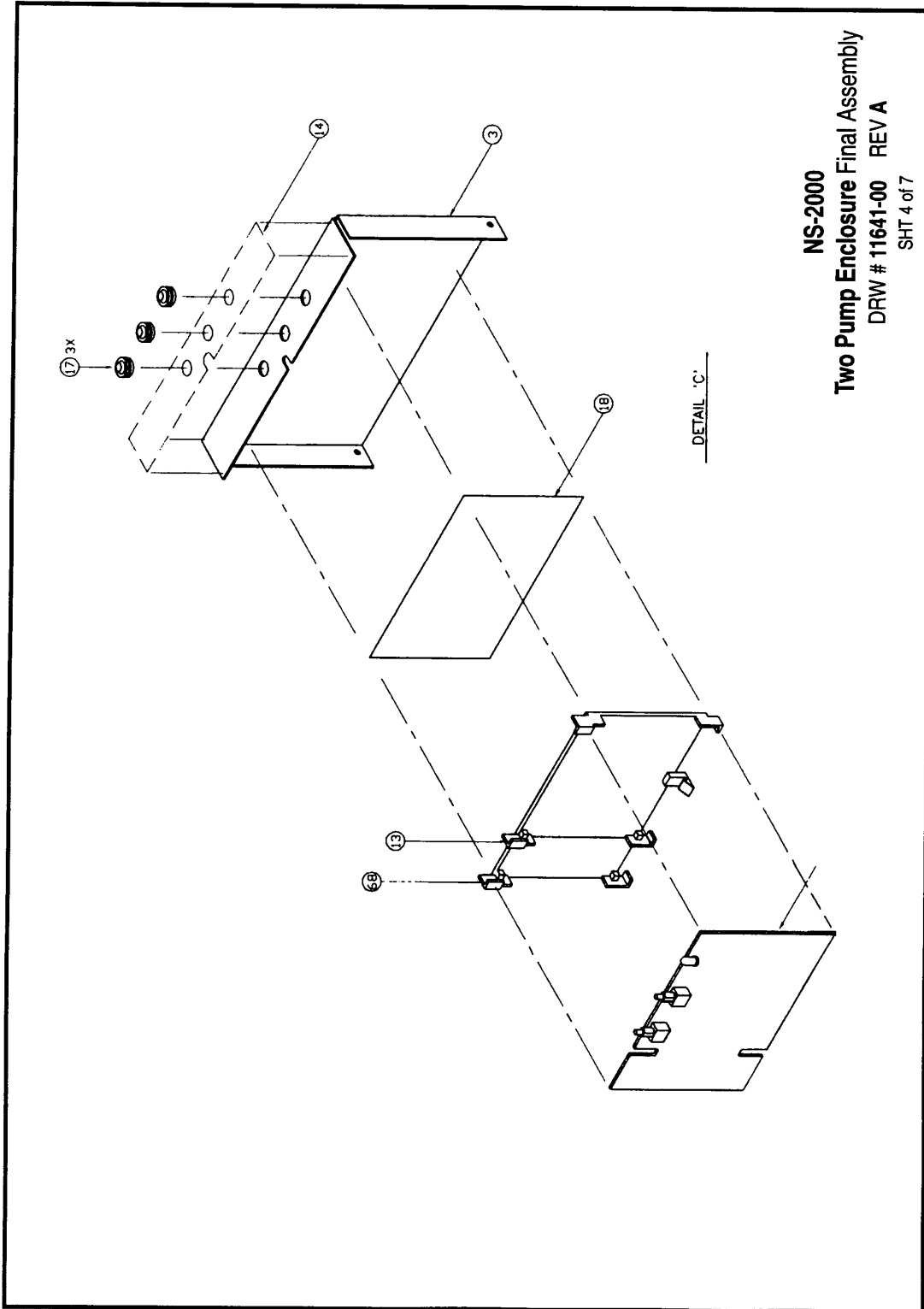

**NS-2000**  
**Two Pump Enclosure Final Assembly**  
DRW # 11641-00 REV A  
SHT 4 of 7

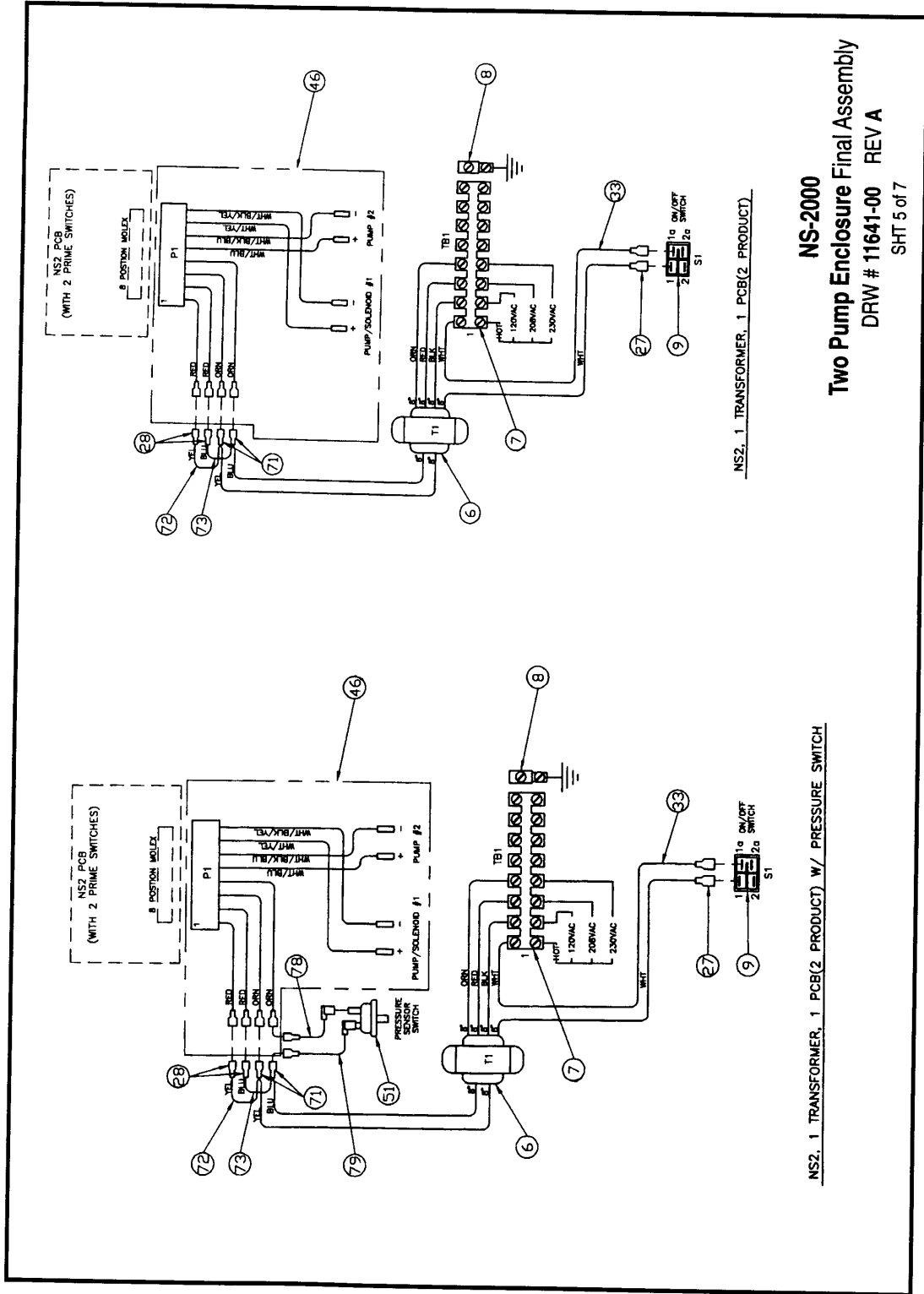

NS2, 1 TRANSFORMER, 1 PCB(2 PRODUCT)

NS2, 1 TRANSFORMER, 1 PCB(2 PRODUCT) W/ PRESSURE SWITCH

**NS-2000**  
**Two Pump Enclosure Final Assembly**  
 DRW # 11641-00 REV A  
 SHT 5 of 7

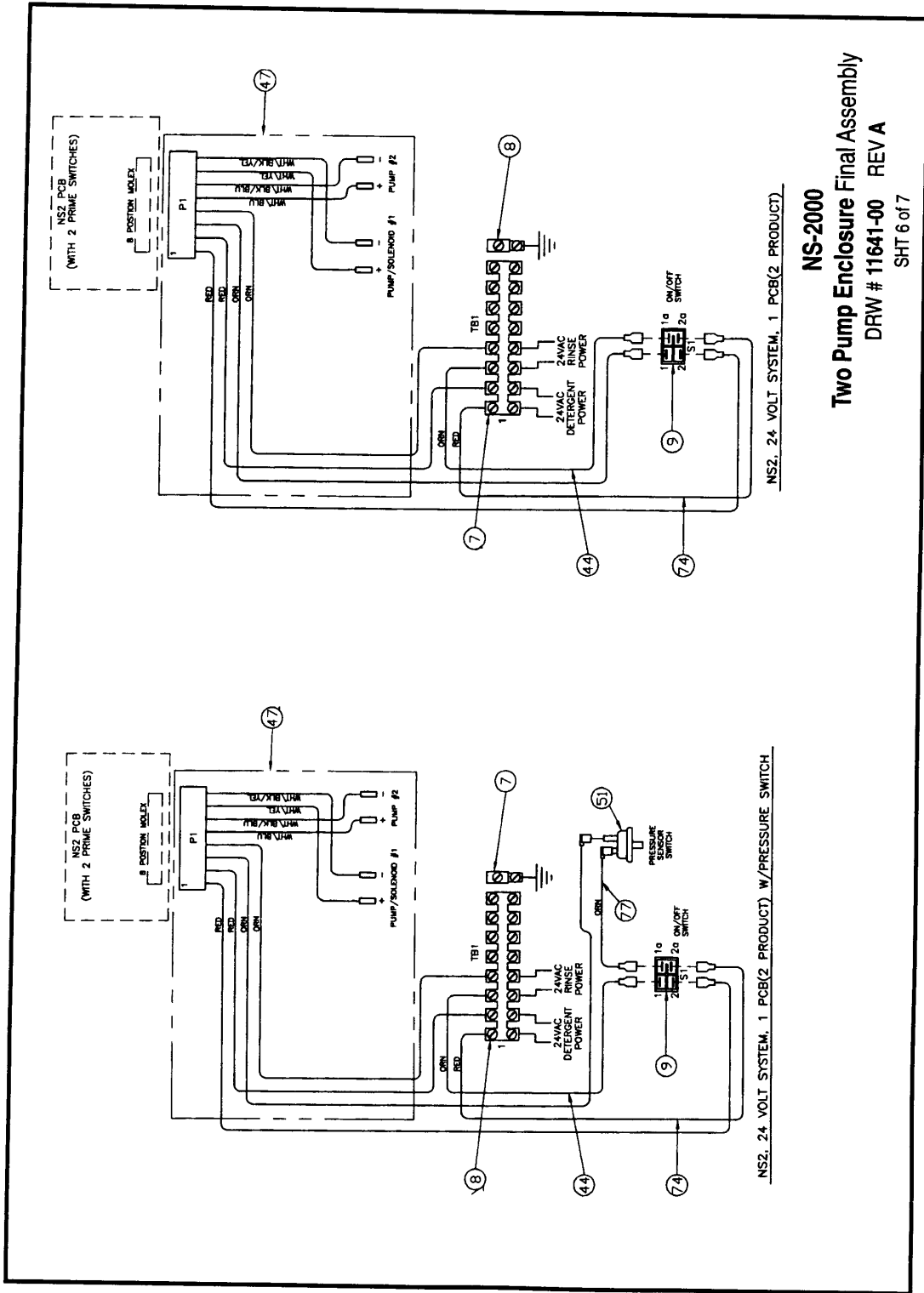

**NS-2000**  
**Two Pump Enclosure Final Assembly**  
 DRW # 11641-00 REV A  
 SHT 6 of 7

