

PR-1100 2 and 4 Liter/Minute Relay Driven Peristaltic Pumps

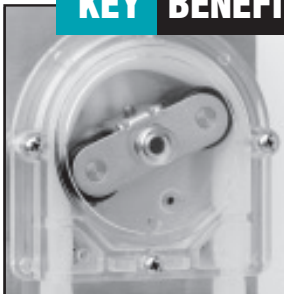

The PR-1100 is a versatile pump built in a durable, wall-mount, Nema 1 stainless steel enclosure. Designed for wall mounting, the cabinet is simple and compact. The pump is triggered by an external dry contact. The PR-1100 is equipped with a fixed speed DC motor that can operate continuously without fear of overheating. Two different motor speeds are available. The 130 RPM motor provides approximately 2 liters per minute. The 260 RPM motor provides approximately 4 liters/min. An internal multitap transformer allows any 115, 208 or 230 Volt AC, 50/60 Hz power supply to be used.

KEY BENEFITS



- Rated for continuous duty
- Compact, rugged stainless steel enclosure
- Reliable peristaltic pump requires no seals or check valves that can clog or corrode
- Selection of pump tube materials allows PR-1100 to pump a wide variety of chemical products
- Ideal companion for Beta conductivity controllers, or other process control equipment

TYPICAL INSTALLATION

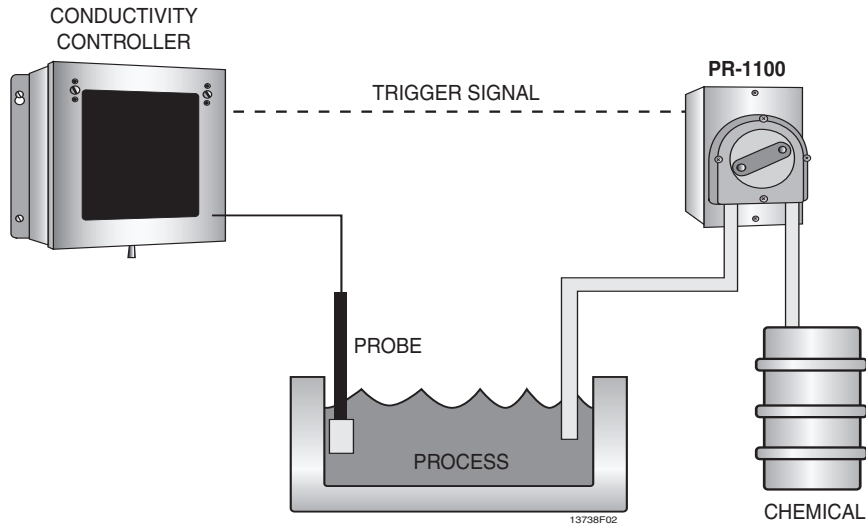

SPECIFICATIONS

SIZE

8.375H x 5.375W x 8.125D (inches)
 (21.3H x 13.7W x 20.6D cm)

WEIGHT

11 lbs (5 kg)

CABINET

Type 304, brushed stainless steel

MOUNTING

Wall mounted with one upper keyhole and two lower mounting holes in the backplate

TRIGGER SIGNAL

Dry contact, rated at 5 Amp

POWER

Multiple input power capability
 115 VAC ($\pm 10\%$), 50/60 Hz, 0.6 A
 208 VAC ($\pm 10\%$), 50/60 Hz, 0.3 A
 230 VAC ($\pm 10\%$), 50/60 Hz, 0.3 A

FUSES

5 Amp, type AGC, 250 VAC, fastblow

OPERATING TEMPERATURE

+36 to 120° Fahrenheit
 +2 to 49° Celsius

PUMPS

Peristaltic, dual roller, self priming and self checking (no back flow)

PUMP DISPLACEMENT

130 RPM, 2 liter/65 oz per min, standard
 260 RPM, 4 liter/130 oz per min, high-speed model
 CSA Approval pending.

DESCRIPTION CODES

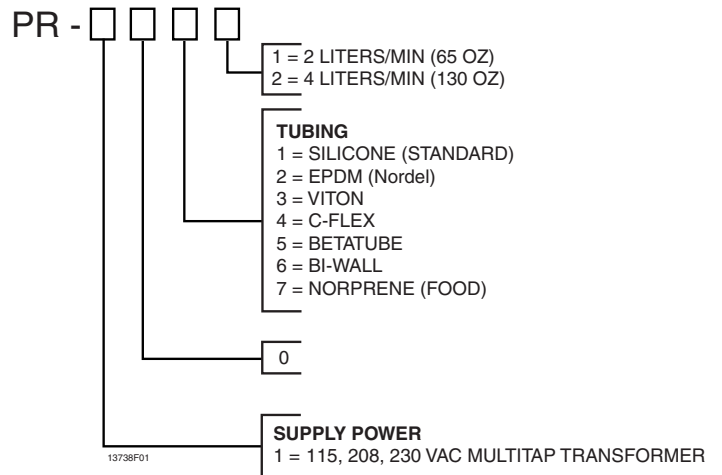

STANDARD ITEMS

Item #	Description
037622	Relay driven 65 oz/min (1.5 liters/min) pump
057418	Relay driven 130 oz/min (3.0 liters/min) pump

Design and specifications subject to change without notice



Beta Technology, Inc
 2841 Mission Street
 Santa Cruz • CA
 U.S.A. • 95060

TEL • 831 • 426 • 0882
 TEL • 800 • 858 • 2382
 FAX • 831 • 423 • 4573
 FAX • 800 • 221 • 8416

Customer Service

TEL • 800 • 899 • 7302 Tech Support
 sales@beta-technology.com

Beta Technology, Inc
 4 Finway, Dallow Road
 Luton LU1 1TR
 United Kingdom

Freephone • 0800 • 052 • 4726
 Tel • +44(0) • 1582 • 528600
 Fax • +44(0) • 1582 • 528111
 Freephone • 0800 • 052 • 4726 Tech Service
 VAT REG.NO.BG.354 - 09975 - 44

Customer Service

europa.sales@beta-technology.com

Online Ordering: <http://www.beta-technology.com>