

NS1000E

Installation & Troubleshooting



Beta

Presentation Objectives

- This presentation is intended for both experienced field personnel familiar with warewashing installations, as well as new field service personnel who have only a rudimentary knowledge of accessing triggers and conductivity control.
- The objective is to train the installer to be able to install NS1000E on either a door or conveyor dishwashing machine, and troubleshoot any unusual conditions they may encounter. To train new installers, we recommend using this presentation in conjunction with an actual installation or at least a lab installation followed by a site visits to see typical conveyor and door machine installations.
- Excluded from this presentation is detailed training on electrical safety, which should always be performed prior to attempting any high voltage installations. In brief, however, power to the dishwasher and dispenser should be shut off at the source prior to opening them, and a voltmeter should be used to verify the power's off prior to doing wiring.



This presentation is comprised of the following sections

- Physical installation: mounting, tubing, solenoid water supply
- Wiring: power connection, trigger/signal wiring
- Programming
- Troubleshooting

Beta

NS1000E Mounting Location

- Pick a spot to the pumpbox(s) on the wall over the dish tray counter or behind the washer; the former is preferred so it's easy for the dishwashers to see and react to alarms.
- Hold the NS1000E up with a level on it and mark the screw holes on the wall; drill, put in screws, and then slide the unit on the screws
- For solid or powder detergent capsule bowls, be sure to install in a location where it's easy for the dishwashers to check and replace the capsule.

NS1000E can be mounted onto the top of the washer using metal bracket kit 018224

Beta

TUBING:

Chemical Pickup Lance Connection



*035623 Detergent 1/4" ID
18" long CPVC standpipe*

*050572 Rinse 1/8" ID 18"
long CPVC standpipe*

- Connect tubes to standpipes as shown at left. The standpipes come with nut fittings to connect to standard 1/4" ID detergent and 1/8" ID rinse polyflow transport tubing
- 1/4" red and 1/4" blue tubing is also available for customers who prefer to use color tubing (*be sure to use a 1/4" T rinse nut fitting if you use 1/4" rinse tubing*)

TUBING: Pump Connection

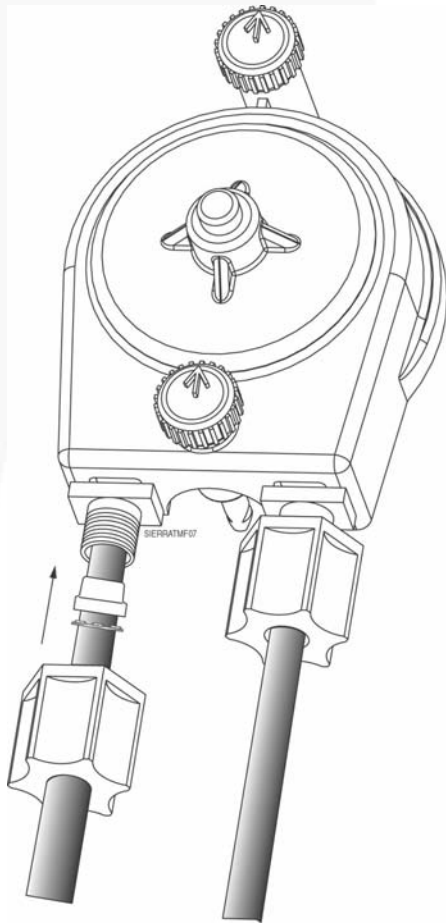

- The left side of the pump is the suction side which should be connected to the chemical supply
- The right side of the pump is the chemical discharge side which will be connected to injection fittings on the washer
- Loosen tube nuts, insert tubes, and tighten nuts as shown

TUBING: Injection Fittings

- Mount the detergent bulkhead fitting in a 7/8" hole above the water line, just above where the probe will be located. Make sure the area has plenty of water circulation, such as an area near the wash pump strainer inlet so the detergent will get circulated immediately
- Add rinse injector to rinse line, in a location away from large amounts of steam or moving parts which can induce thermal or physical fatigue on injector plastic over time. If using a pressure switch or a sanitizer, an injector with two connections is required, one for the rinse and one for the sanitizer or copper tubing line to the pressure switch. We recommend using a stainless steel injection fitting if installing in a remote location, since they are impervious to thermal and physical fatigue
- Tubes connect to the detergent bulkhead fitting and rinse injection fitting just like they do to the pump nuts.

Don't use an old hole if it's in the wrong spot! Making a new hole during installation always takes less time than getting a trouble call and making a new hole on a separate trip

Beta

Solenoid & Bowl

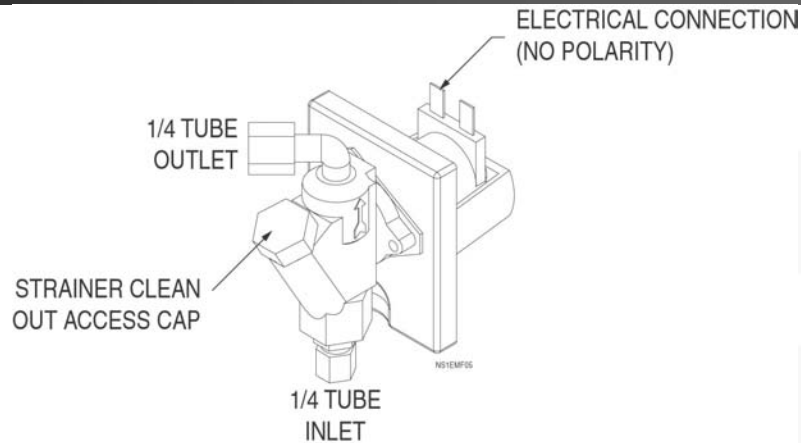

- Connect water supply tube to water inlet on bottom of solenoid. Be sure to verify which way the arrows point on the solenoid, since standard warewash solenoids have the water inlet on the bottom whereas OPL solenoids have it on the top.
- Connect outlet to bowl
- Mount bowl in a location where it will be easy for the dishwashers to replace the detergent capsule

Beta

WIRING: Main Power

- NS1000E uses triggers as its power source, typically using a separate power/signal for detergent and rinse.
- Crimp a 10-12 GA (4mm²) ground wire to the ground connection next to the terminal block.
- Run power and ground wires through a strain relief such as 090369 or conduit connection on bottom of unit. Replace cover so it supports the surface around the knockouts prior to knocking them out
- Never run the probe wire next to the power or trigger wires; the electrical noise they emit can interfere with getting a correct probe reading

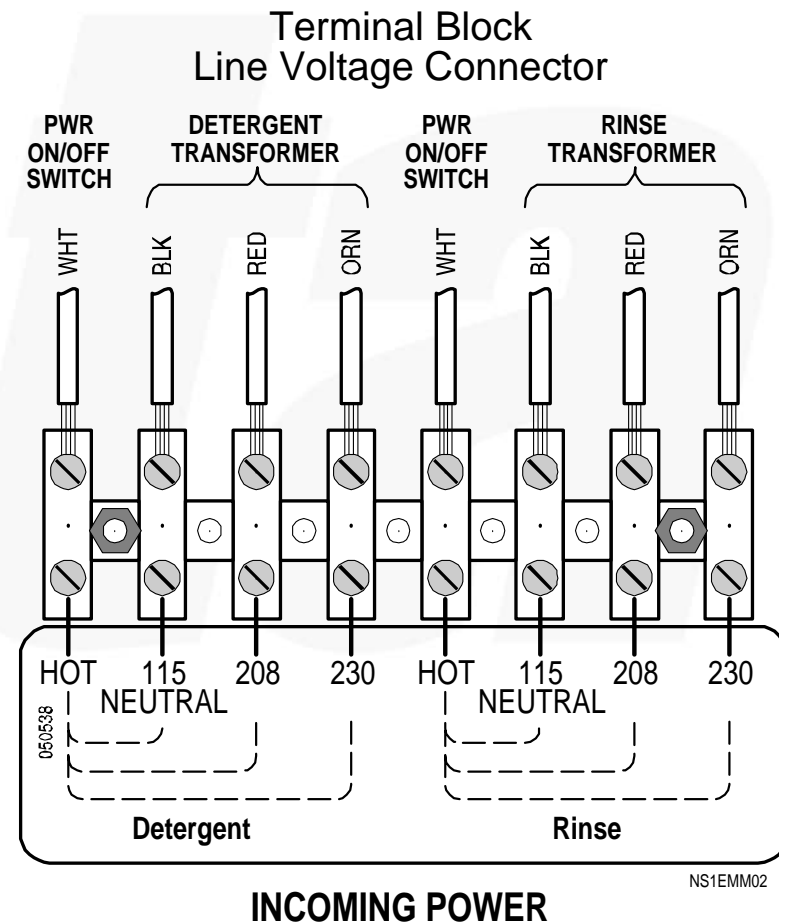

WIRING: Probe Connection

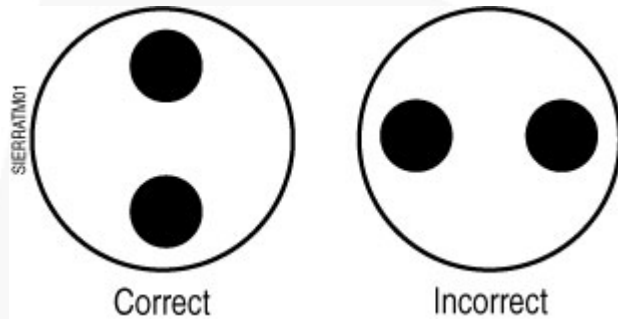

Be sure you do not mount the probe in an old hole that's a bad location, since that can produce bad probe readings or subject the probe to too much thermal shock

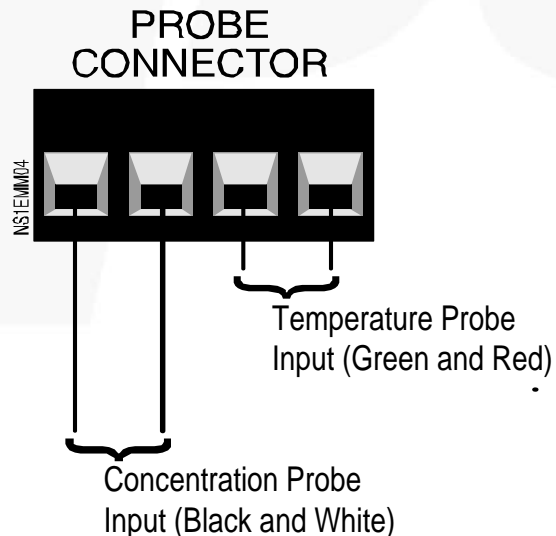

- Mount conductivity probe 3-4 inches (8-10 cm) from the bottom of the wash tank, about 3"-5"/7-12 cm over the detergent injection point and as close to the wash pump intake strainer as possible. The terminals should be vertically oriented as shown.
- Ensure the probe location is not close to heater elements, corners, or in the path of moving mechanical components. Ensure the probe location is in an area with plenty of circulation
- Connect probe wires to conductivity input on the PCB. If using a temperature compensated probe, use a four wire cable and run the thermistor/temperature wires to the temp input

PROGRAMMING: Button Functions

- To enter programming mode, hold down the Program/Run button for 5 seconds.
- The left digit on the display is the setup menu number and the two right digits are the setup menu value.
- Use the Program/Run button to change to the next menu and the prime buttons to change the menu values.
- The detergent prime button increases the value and the rinse prime button decreases the value. (Feed times are set by pumping the desired amount into a graduated cylinder)
- The alarm volume adjustment potentiometer adjusts the alarm volume from 0 – 93 decibels

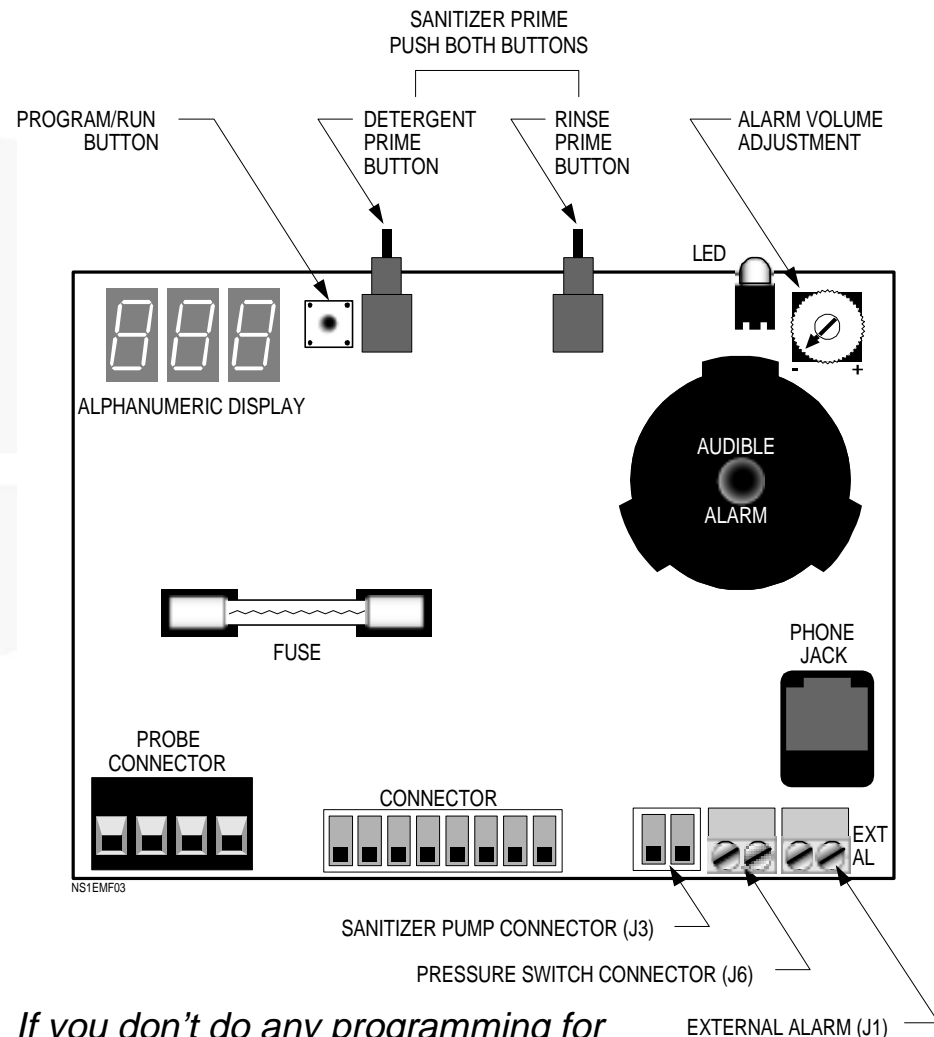

If you don't do any programming for 60 seconds, the NS-1000E will automatically return to the run mode.

peia

PROGRAMMING: Menu Guide

Menu #	Probe Mode	Probeless Mode
1	Set to 01 for probe	Set to 02 for probeless
2	Low detergent alarm delay time: 0-180 seconds in 10 second increments, so "209" is a 90 second delay time	Conveyor machine rack time: 0-60 seconds (will dose detergent recharge based on this interval)
4	Detergent concentration setpoint: 0-70 Beta Units	Detergent Recharge: To program this setting, hold detergent prime button down to dispense correct recharge amount. Amount displayed as 0-20 second range for door machines, 0-6 second range for conveyor machines
5	Detergent overfeed stop: 0-240 seconds in 10 second increments after alarm condition, so "524" has the pump stop after 240 seconds of on time after the alarm	Detergent initial fill: Use the detergent prime button to set the desired amount. Amount displayed as 0-24, 10 second increments of 0-240.
6	Rinse pump delay: 0-99 seconds	Rinse pump delay: 0-99 seconds
7	Rinse pump speed 0-99%	Rinse pump speed 0-99%
8	Rinse pump run time 0-99 seconds (set to 00 for conveyor machine)	Rinse pump run time 0-99 seconds (set to 00 for conveyor machine)
d	Reduced detergent feed rate: 01= 1 second on, 9 seconds on, 09=9 seconds off 1 seconds off, 10 = on continuously	Detergent initial fill trigger: Set to 00 to start feed once machine power's been on 20 seconds. Set to 01 if using a dedicated separate trigger for initial charge.
E	Sanitizer trigger: Set to 00 to feed with rinse or 01 to feed with detergent	Sanitizer trigger: Set to 00 to feed with rinse or 01 to feed with detergent
F	Sanitizer pump speed: 0-99%	Sanitizer pump speed: 0-99%

NS1000E contains this chart in the manual, and in a reference card you can leave in the dispenser, so you're sure to always have this info handy!



PROGRAMMING: Menu 2

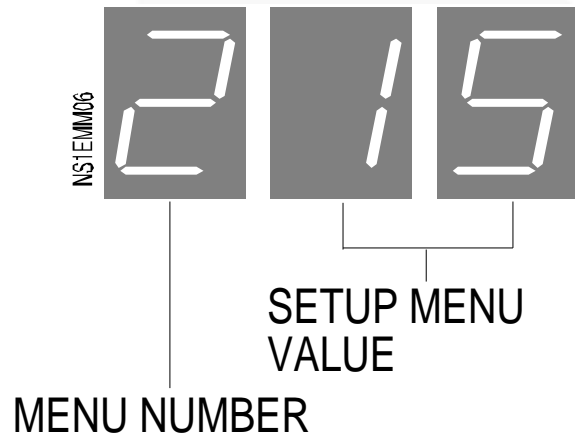

- After picking probe mode (01) or probeless mode (02) on menu #1, you'd proceed to menu #2.

- Probe mode:** As shown in the reference chart, menu #2 is **alarm delay** in probe mode. I.e. it's the amount of time the detergent will be on before triggering an alarm to indicate out of product or drain open.

- The example on the left shows a value of 15 for menu #2; in probe mode this would cause the alarm to start beeping after 150 seconds of detergent on time.

- Probeless mode:** This menu is **rack time** in probeless conveyor mode. It isn't used on probeless door machines. The example on the left shows a value of 15 seconds, which in probeless mode on a conveyor would cause the recharge to come on every 15 seconds.

PROGRAMMING: Menu 4

•**Probe Mode:** In probe mode, menu 4 is the setpoint. Setpoint controls detergent concentration, and varies with the chemical being used and water hardness. In the example shown on the right, a setpoint of 35 Beta Units has been programmed.

•**Probeless Mode:** In probeless mode, you'll push the detergent prime button to pump the amount of chemical required for recharge, and the screen will show the number of seconds of pump time. (Note you push once to start and again to stop)

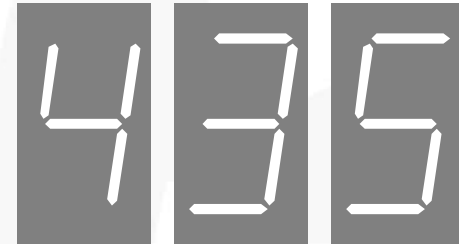

435

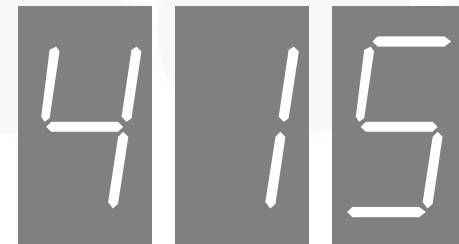

415



Beta

PROGRAMMING: Menu 5

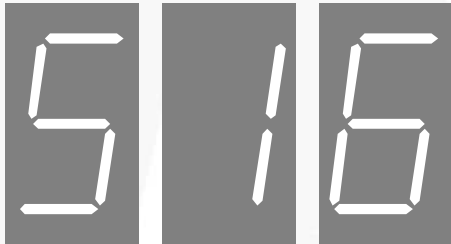

- Probe mode:** Menu 5 is the overfeed stop, or amount of time the alarm is on before the detergent is shut off.
- Remember total detergent alarm time before stopping is low detergent alarm delay (menu 2, beeping alarm) + overfeed stop (menu 5, steady on alarm)
- Probeless mode:** Menu 5 is detergent initial charge time. Use the detergent prime button to dispense the requisite amount of product into a graduated cylinder, pressing the button once to start and once to stop. The rough number of seconds will be displayed on the screen in 10 second increments.
- Don't worry that the unit shows "02" for either 22 or 28 seconds; the dispenser keeps the precise time in memory even though it can't display it on the 3 digit screen.

Beta

PROGRAMMING: Menu 6

•**Probe Mode & Probeless Mode:** Menu 6 is rinse pump delay time. For most installs it will be 0, as shown on the right.

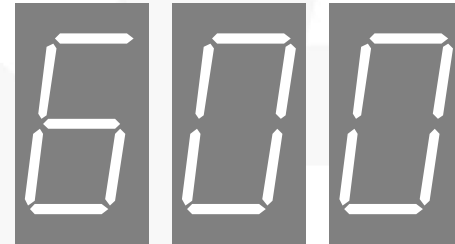

Beta

PROGRAMMING: Menu 7

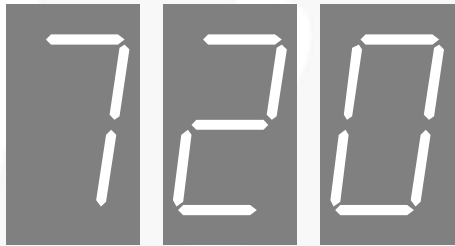

- **Probe & Probeless Modes:** Menu 7 is the rinse speed

Beta

PROGRAMMING: Menu 8

•**Probe Mode & Probeless Mode:** Rinse runtime limit, set to 20 seconds in the example on the right

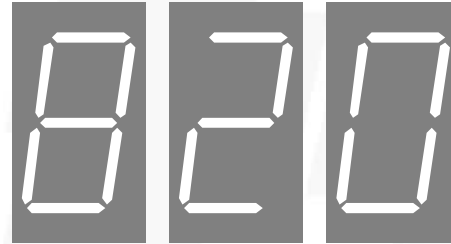

PROGRAMMING: Menu “d”

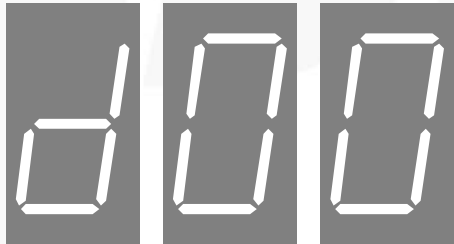
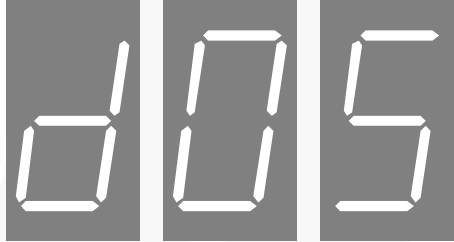

•**Probe Mode:** Menu d reduces detergent overusage by cycling the pump on and off.

- 01=1 second on, 9 seconds off
- 05=5 seconds on, 5 seconds off (as shown in the example, a rather typical setting)
- 09=9 seconds on, 1 second off
- 10=on continuously

•**Probeless Mode:** Menu d dictates what triggers initial charge. Initial charge is the dose of chemical when the tank is filling.

- 00=Machine power triggers initial charge once on for 20 seconds. Use this setting with all door machines, and with conveyors where a special separate signal for tank fill can't be found. When the detergent signal's received, recharge will begin immediately and then initial charge will come on after 20 seconds.)
- 01=Conveyor with disparte initial fill signal only (dry contact through probe or temp connection)

PROGRAMMING: Menu E

•**Probe Mode & Probeless Mode:** Menu E determines whether the sanitizer pump will turn on with the rinse or detergent.

- 00=Feed sanitizer with rinse
- 01=Feed sanitizer with detergent



PROGRAMMING: Menu F



- **Probe Mode & Probeless Mode:** Menu F determines sanitizer pump speed, 0-99%
- In the example shown, the speed has been set to 20%

TROUBLESHOOTING: Probe Diagnosis

Probe Reading	Solution
LO (00)	No reading usually means the wires aren't properly connected. Check all the wire connections, and the wire itself for damage. If everything's hooked up correctly, the problem could be delamination; to check for this detach wires from probe, attach both voltmeter wires (use ohm setting) to one probe post, with one wire on the sensor side, one wire on the screw/wire attachment side to verify continuity. Repeat for the second post. Scrap probe if there's no continuity, and verify probe location meets guidelines before installing a new one
Too low, overdosing	Check tank for extreme scale build up. If there's a lot of scale, clean the probe. (VCP compensates for scale, and usually the account will delime the tank before the scale gets so bad that VCP can't compensate for it.)
Too high, not dosing enough	Replace the probe. This failure should only be seen on pre-Y2K temperature compensated probes. Newer temp comp probes are medical grade and shouldn't fail in this manner. (VCP will also compensate for this problem in most cases.)
HI (99)	This failure usually indicates a short. Check the wires to ensure there's no short, and check the back of the probe for moisture. Sometimes if the probe is wet in back, replacing it and allowing it to dry will allow it to function again. In rare cases moisture may work into the body of the probe; when this occurs the probe can't be dried out and instead must be scrapped.

TROUBLESHOOTING: Solenoid Not Activating

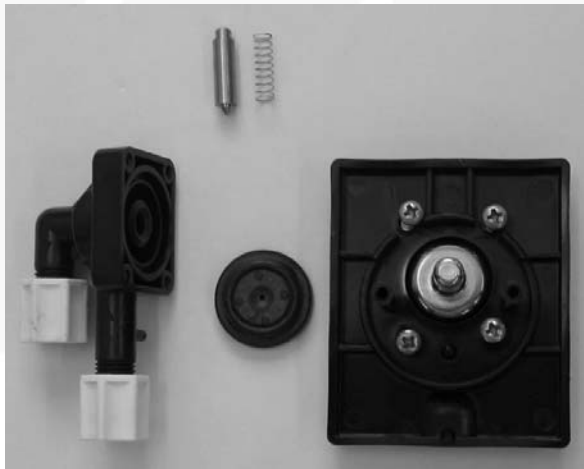
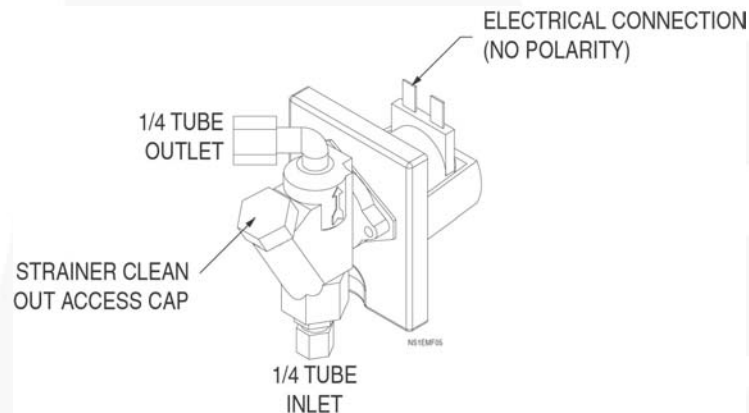

- If the solenoid doesn't make a clicking sound when turned on/off, verify wires are attached and supplying voltage with voltmeter.
- If there's no voltage from the PCB, try supplying voltage by priming. If priming doesn't supply voltage to the solenoid replace the PCB; if it does, correct programming and troubleshoot probe
- If the dispenser is turning on voltage to the solenoid, but it isn't feeding or isn't making a click sound, it's likely clogged.
- If it's a metal solenoid, remove the strainer cap shown at top left, clean the cylinder filter, and reassemble
- If it's a plastic solenoid, disassemble and clean the round rubber diaphragm shown at left; if diaphragm is damaged replace it or the solenoid

Beta

TROUBLESHOOTING: Miscellaneous Problems

Issue	Answer
Screen dead	Screen will only have power when dishmachine is on, and dispenser switch is set to on. Check switch and put a rack in the machine to get power.
How often do I replace tubes?	The Beta rinse flex tube lasts at least 6 times longer than most competing tubes. On a door machine, it should last a minimum of several years as long as it's not injecting into water pressure over 35 PSI. On a typical conveyor machine, it should last 1-3 years. Even in a flight kitchen you can expect a life of 4 months. The norprene detergent tube should last a comperable amount of time.
How do I adjust the alarm?	Lift the NS1000E lid and adjust the dial to change the alarm volume.

NS1000E

Installation & Troubleshooting



Beta