



# **Summit E & Summit XL**

**Dispensers for small OPL to large laundry  
washer extractors and tunnels**

***Beta***

# Same platform adapts to every install

- **Summit E and XL handle up to 8 pumps**
- **E uses small and/or medium pumps, XL uses medium and/or big pumps**
- **Operating modes handle all washers and tunnels: smart relay, sequence, formula, latched, and TAFS tunnel automatic formula selection.**
- **TAFS can be configured to run on washer extractors**
- **Power supply accepts any power 90-260V**



*Summit E is available in two enclosure sizes, one up to 4 pumps, and one up to 6 pumps. An auxiliary pump box is used for pumps 7 and 8 on both Summit E and Summit XL.*



**Beta**

# Programmer = formula selector

- **Summit's ergonomic programmer does double duty as a formula selector.**
- **Formula names can be two 8 character lines, such as "Color Towels"**
- **Laundry workers like Summit since it allows them to select formulas by name using the "+" & "-" buttons, rather than having to refer to a wall chart.**



**Beta**

# Intuitive programming saves you time & money



*Single screen formula programming:  
simply enter pump delay, pump number,  
and the pump volume for each trigger!*

*Independent pump delays and up to  
three pump actions per trigger!*

- **“I programmed it in under 10 minutes!”**
- **SmartScreens lead you through the programming so quickly, a first-time user can program his or her formulas in under 10 minutes.**
- **Smart relay mode reduces programming time since you don't have to calculate runtime. Just program the washer to turn the trigger on for one second per 0.3 oz (or 10 ml) of chemical you need!**

**Beta**

# Clone formulas

- **Summit is easy to program, but what's really nice is when you don't have to!**
- **Use the copy feature to copy from one formula to another. This saves time by not requiring each formula to be completely reentered.**
- **Once one dispenser is programmed, you can upload or "receive" all the data in the programmer, and then download or "send" it to another dispenser, and you'll have a clone---no programming required!**

Formula Number  
to Copy from(F1-F16)

COPY F1  
To F???

SUMMITXLMS32

Formula Number  
to Copy to (F1-F16 or "all")

A "+" in this position  
indicates that a  
formula already exists  
for that formula number.

Receive?  
Press #

SUMMITXLMS37

Send?  
Press #

SUMMITXLMS40

**Beta**

# Easy to calibrate

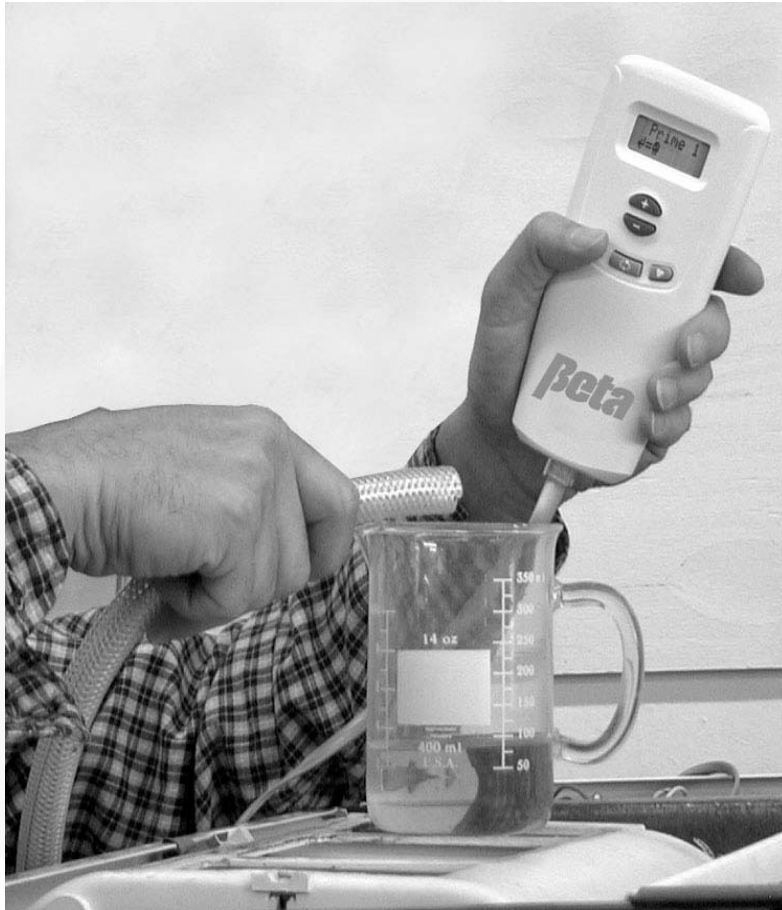

- **Programmer fits in your hand like a TV-remote, and it's even easier to use.**
- **Prime and calibrate with the programmer in one hand and a measuring cup in the other.**
- **Walk around with the programmer while testing triggers and monitoring washer functions.**

**Beta**

# Robust pumps save money

---

- **Summit E and Summit XL come with special thick-wall tubes that are field-proven to last longer, decreasing your service time and spare parts costs.**
- **Speed control increases tube life and dosing accuracy with extremely viscous chemicals.**



***Beta***

# Manifolds reduce install and maintenance time

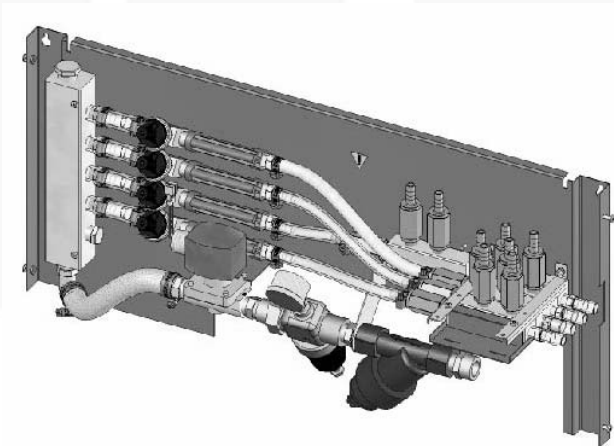
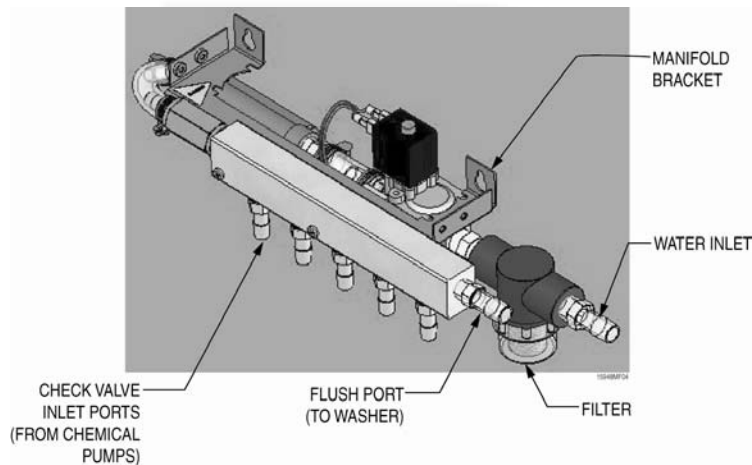

- **3-port, 5-port and 8-port flush manifolds come preassembled, with brackets for fast mounting.**
- **Integral water filters reduce maintenance from rust or other contaminants in the water supply.**
- **Translucent parts allows you to spot and eliminate precipitates before they turn into a clog and trouble call**
- **Flow switches ensure system won't fill transport lines with undiluted chemical if water supply off, reducing maintenance time and increasing system safety**

*The new tunnel flush manifold makes tunnel installations easy!*

**Beta**

# Data for billing purposes

- **LOAD COUNTER:** Count loads washed to ensure accounts being charged on a per-load basis don't underreport the number of loads washed.



*Includes alarm counts to show how many loads experienced hygiene or other problems*

- **PUMP RUNTIME COUNTER:** Counts pump runtimes in minutes. Enables you to calculate product usage and keep track of tube life.

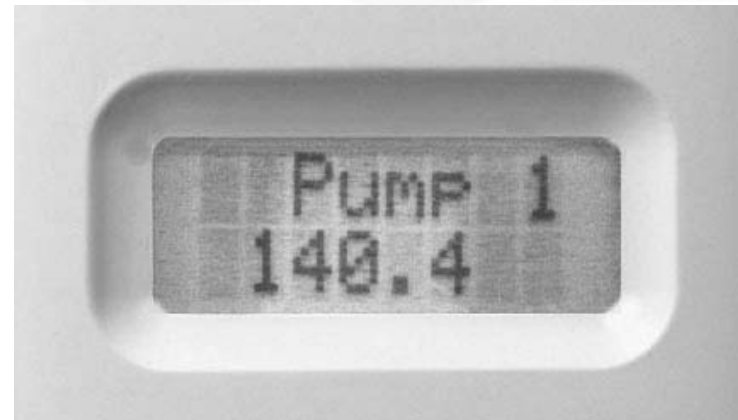

# Data logging with optional data PCB

<b>Chemical</b>								
Network ID: 1 ILS			E312			Report Printed: 14-Sep-2005		
Account Name: Sample ILS Site						Report Start Date: 25-Aug-2005		
Washer Number: 1 675 Ellis						Report End Date: 05-Sep-2005		
Chemical	Shift 1		Shift 2		Shift 3		All Shifts	
Name	Amount	Cost	Amount	Cost	Amount	Cost	Amount	Cost
alkali	60.40	\$259.71	0.63	\$2.73	0.27	\$1.15	61.30	\$263.58
anti chlor	2.12	\$10.48	0.08	\$0.39	0.00	\$0.00	2.20	\$10.87
bleach	35.50	\$37.28	0.74	\$0.77	0.00	\$0.00	36.24	\$38.05
builder	28.87	\$469.21	0.57	\$9.20	0.42	\$6.87	29.86	\$485.28
detergent	29.19	\$302.16	0.42	\$4.37	0.53	\$5.52	30.15	\$312.06
peroxide	0.42	\$1.81	0.00	\$0.00	0.00	\$0.00	0.42	\$1.81
softener	2.05	\$9.03	0.08	\$0.35	0.00	\$0.00	2.13	\$9.38
sour	6.54	\$41.21	0.11	\$0.66	0.11	\$0.66	6.75	\$42.53
<b>Total Costs:</b>	<b>\$1,130.88</b>		<b>\$18.48</b>		<b>\$14.20</b>		<b>\$1,163.57</b>	
"Amount" is measured in Gallons								

**Just plug the data PCB into the E or XL main PCB, and you're logging data!**

**Download data at anytime into a laptop, either locally or over a modem and phone line**

**Enter chemical costs into our ManageNet software, and you can instantly generate a chemical usage cost summary**

**Finally you can offer complete chemical cost tracking to your customers, on all washers in the laundry!**



# Alarms that help you get new business

---

- **HYGIENE VERIFICATION:**  
Set up to three hygiene parameters of minimum temperature and minimum duration. Use any or all of them on selected wash load types, such as nursing home bedding and hospital gowns.
- **LOW LEVEL ALARM:**  
Optional low-chemical alarms help alert users if chemical levels are low, so they can have consistent wash quality, and you can have consistent chemical sales!

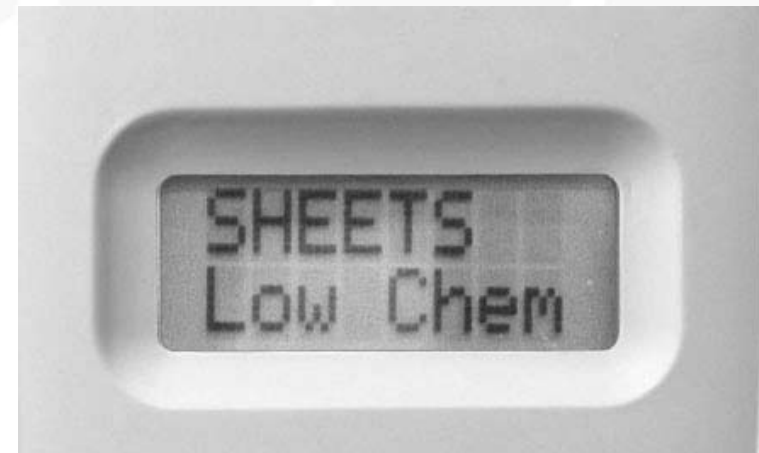

**peia**



# **Summit E & Summit XL**

**Dispensers for small OPL to large laundry  
washer extractors and tunnels**

***Beta***