

SierraT

Time-Based Dosing System

Installation and Operation Manual



SAFETY NOTES

- When servicing SierraT, make sure unit is disconnected from power source and no triggers are alive.
- Refer installation and service to qualified personnel only. Installation must comply with all applicable plumbing and electrical codes.
- When removing or installing SierraT pump components, wear adequate protective clothing such as gloves and safety glasses or goggles.

INTRODUCTION

This manual describes how to use the Sierra Time-Based Dosing System.

Material in this manual is subject to change without notice. Manual revisions will be made on an as needed basis. Special circumstances involving important design, operation or application information will be released via Equipment Technical Bulletins.

If the equipment is used in a manner not specified by Beta Technology, Inc. or Beta Europe, the protection provided by the equipment may be impaired.

© Beta Technology, Inc., Beta Europe, 2002

OVERVIEW

Sierra T is a CSA/UL and CE approved two or three-chemical product dispensing system for time-based applications such as CIP. Plain language programming makes setup and installation simple.

The unit allows two AC/DC triggers and three dry-contact closures to provide three separate trigger inputs to control peristaltic pumps. Trigger 1 and Trigger 2 can be either an AC/DC signal input or a dry-contact closure. Trigger 3 can only be a dry-contact closure. Each pump can be programmed with its own delay and runtime for maximum system flexibility. For example, Trigger 1 can be assigned to activate Pump 1 and Pump 2 while Trigger 2 can be assigned to activate Pump 3, with each pump having a different delay and runtime.

Sierra T can be run in either RELAY MODE (pumps only run during active input trigger) or TIME MODE (pumps run upon receiving valid input trigger for a preprogrammed time).

A LOW PRODUCT alarm can also be connected to ensure that there are always chemicals available for dispensing. Password protection ensures that only approved field service personnel can modify Sierra T programming. A universal power supply allows the dispenser to be used globally without modification.

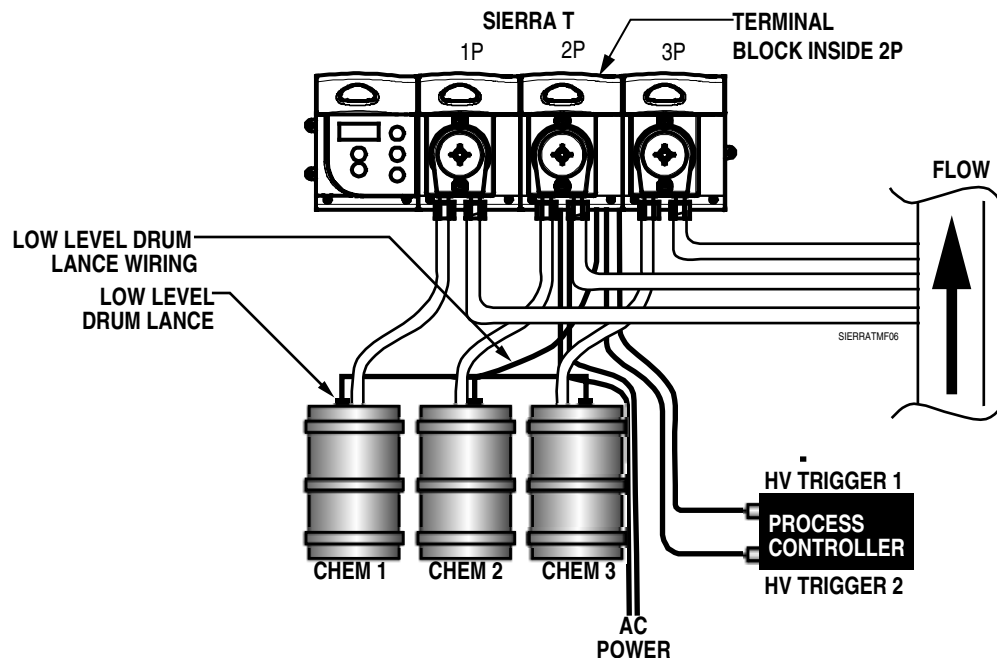

Figure 1a. Typical Installation

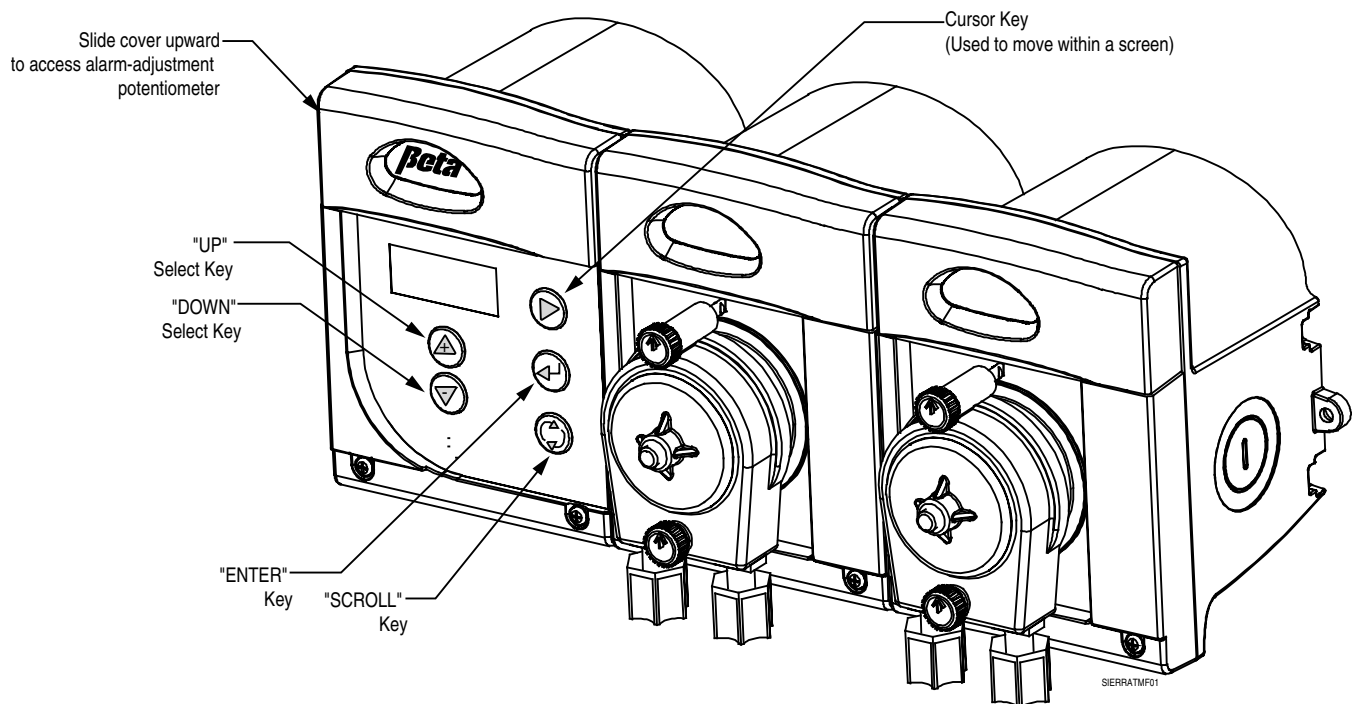

Figure 1b. SierraT, Typical Two-Product System

EQUIPMENT INFORMATION

General

All programming is done through a 5-button keypad and 2-line, 16-character display.

“Smart” Screens

The “Smart” Screen concept simplifies the configuration process by only displaying the screens that are applicable to your application mode. For example, if you program your SierraT to run in Relay rather than Time mode, the SierraT will only display subsequent programming and status screens that apply to Relay mode.

Priming

The pumps are selected using the UP/DOWN keys, primed by pressing the ENTER button when the desired pump name is displayed on the screen.

ENABLE/DISABLE Feature for Machine

Maintenance

SierraT allows the operator to disable chemical dosing with the push of a button, allowing him to perform machine maintenance procedures without dispensing chemicals. When maintenance procedures are complete, dosing may be re-enabled with the push of a button.

SPECIFICATIONS

PHYSICAL DIMENSIONS, CONSTRUCTION AND MOUNTING

Three-Product Enclosure

Height	Width	Depth	
5.75	15.25	5.5	Inches
14.61	40.96	13.97	Centimeters

Two-Product Enclosure

Height	Width	Depth	
5.75	11.50	5.5	Inches
14.61	31.12	13.97	Centimeters

Weight

4.38 lbs (2 kg) maximum for 3-pump system. All other configurations will weigh less.

Cabinet Material

ABS – Flame Retardant
IP54 Water-Resistant

Mounting

Wall mounted with stainless steel bracket, allowing easy installation in all locations. Use #8 x 1 inch (#8 x 25mm) screws.

OPERATING CONDITIONS

Ambient Operating Temperature

36 to 104° Fahrenheit (2 to 40° Celsius)

Electrical Power Configurations

100-240VAC, 50-60 Hz, 0.42 Amp (max)

Fuse

SierraT has no user-serviceable fuse. Protection provided by power supply.

COMPONENTS

Pumps

Peristaltic, dual roller, self-priming and self-checking.

Tube Materials

High Flow

Norprene (Standard), B-Flex, Silicone, Viton, Nordel, C-Flex

Medium Flow

Norprene (Standard), B-Flex, Silicone, Nordel, C-Flex

Low Flow

Norprene (Standard), B-Flex, Silicone, Norprene (food grade)

Pump Flow Rates

High Flow: 0.188" (4.77 mm) ID tube,
(5.0 oz, 150 ml per minute)
0.25" (6.35 mm) I.D. tube, (8.5 oz, 255 ml/min)
B-Flex tube only

Medium Flow: 0.125" (3.18 mm) ID tube,
(2.0 oz, 60 ml per minute)

Low Flow: 0.063" (1.60 mm) ID tube,
(0.5 oz, 15 ml per minute)

Triggers

Voltage Range

24VAC to 240VAC
30VDC to 100VDC

Current

0.5 mA minimum (at 24 VDC)

Hydraulic Performance

High Flow

Maximum Vacuum 8 in (200 mm) of mercury
Maximum Pressure 1.4 bar (20 psi)

Medium and Low Flow

Maximum Vacuum 8 in (200 mm) of mercury
Maximum Pressure 2.1 bar (30 psi)

ALARMS

SierraT has an adjustable, audible alarm. To adjust alarm volume, slide top cover upward on controller unit (see Figure 1b), and adjust potentiometer using a small, flat-head plastic screwdriver. To increase volume, turn potentiometer clockwise. Emits 80db at 4 feet (1.22 meters). Alarm acknowledgement will defer display of any new alarms up to five minutes.

Low Level Alarm

This alarm is activated by a contact-closure 4 (see Figure 5). Display reads "CHECK PRODUCTS". The low-level contact closure can be wired in parallel for use with multiple low-level sensors.

APPROVALS

CE approved
CSA

INSTALLATION & SETUP

PHYSICAL INSTALLATION



Refer installation and service to qualified personnel only. Installation must comply with all applicable plumbing and electrical codes.

Mounting the Unit

Carefully select a place to mount the unit. Remember that there must be room around it for access to switches, buttons, wires and tubing, and to open enclosure for installation and maintenance.

Mount the unit against a stable wall with the pumps side-by-side and their tube openings at the bottom. Avoid steam and other sources of moisture, such as from spray or splash. Do not subject the unit to temperatures outside the range 36°F to 104°F (2°C to 40°C).

We recommend mounting the unit with the mounting bracket rather than using the end tabs.

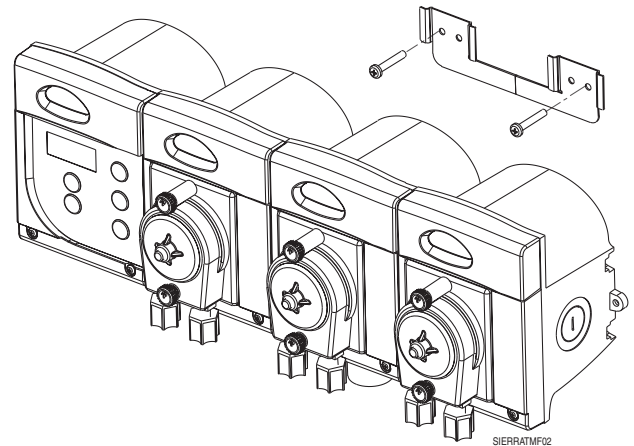

Figure 2. SierraT with Mounting Bracket

Removing Knockouts

SierraT's 7/8" knockouts are located on the bottom of the enclosure, and intended for flexible conduit only.

To remove knockouts in plastic enclosure (on pump 2P), use a flathead screwdriver to puncture. When this is complete, twist and break knockout to remove. Do not use excessive force as the plastic enclosure could be damaged.

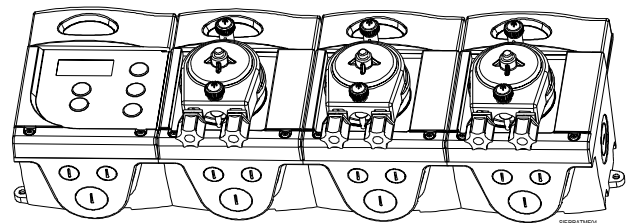

Figure 3. SierraT, Bottom View with Knockouts

A complete schematic with a terminal block cross-reference is available in **Appendix B**.

A selection of plugs, strain reliefs and conduit fittings is listed in the **Accessories and Spare Parts** section.

Opening Unit for Wiring

Slide 2P (see Figure 5) cover up and gently pry off by inserting a screwdriver under the side. Remove screws from four corner of cover to open unit.

Connecting Chemical Supply Lines

Delivery Lines		
Pump Type	Inlet	Outlet
High Flow	1/4 inch (6 mm)	1/4 inch (6 mm)
Medium and Low Flow	1/4 or 1/8 (4 or 6 mm)	1/4 or 1/8 (4 or 6 mm)

Table 2. Pump Types/Sizes

Chemical Input Lines

1. Connect the 1/4 or 1/8 inch (4 mm or 6 mm) line to the nut on the left (inlet side) of the pump squeeze tubes. Tighten the nuts on the fittings. Make sure the connection is airtight.

To ensure an airtight connection between the chemical inlet tube and the fitting, push the tube all the way into the fitting until it stops. The best way to do this is to:

- a) Remove the nut from the fitting.
- b) Put the fitting then end of the chemical line and slide the tube through the nut until 1/2" (13 mm) of tube extends through the nut.
- c) Push the tube into the appropriate tube end.
- d) Push the nut until it meets the fitting.
- e) Tighten to a secure fit. See Figure 4

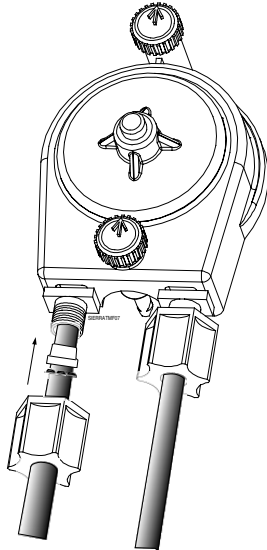

Figure 4. Installing Chemical Tubing



It is very important that the nut components be installed correctly, as shown in Figure 4.

2. Run the lines to the chemical drums, and secure the end of each supply line into its respective container. Use a snap-in standpipe for liquid detergent lines. To ensure that chemical is properly supplied to SierraT, we recommend using a standpipe or other securing device to support and hold the

chemical uptake tube in place within the chemical drum. A plastic standpipe is the **Accessories and Spare Parts** section of this manual.

3. Cut the line at a 45° angle.
4. Press the feed end of the line into the open part of the U.
5. Leave the bottom of the standpipe slightly lower than the inlet of the line.

High and Medium Flow Pump Output Lines

1. Connect the 1/4 inch line to the nut on the right (outlet side) of the squeeze tubes. Tighten the nut on the fitting.
2. Run the feed line to a bulkhead or injector fitting (see **Accessories and Spare Parts** for a complete listing). Use as short a line as possible and keep the lines away from steam pipes, open flues or other areas where machine operators could accidentally damage them.
3. In this and other output line runs, always try to avoid uphill runs.
4. Secure the line into the fitting.

Medium Flow Pump Output Line

1. Connect the 1/8 inch (4 mm) or 1/4 inch (6 mm) line to the nut on the right (outlet side) of the pump squeeze tube. Tighten the nut on the fitting.
2. Run the feed line to the plastic injector/check valve fitting (see **Accessories and Spare Parts** for a complete listing).



The medium and low flow pump tube is capable of pumping against 40 psi but it is not advisable to operate at this level. The pump tubing life will be severely shortened.

ELECTRICAL CONNECTIONS



- Dangerous voltages may be present in the enclosure.
- Refer installation and service to qualified personnel only.
- Installation must comply with all applicable electrical codes.
- Wire size for Main Power and all high voltage connections must be a minimum of 20 AWG, rated for 600 volts.
- Suitable earth ground must be provided.
- A service disconnect must be provided for either this equipment, or the equipment to which it is attached.
- All 7/8" knockouts are intended for flexible conduit only.
- All wires should be routed through the bottom knockouts, through either strain relief or conduit.

Electrical Connection Requirements

- A: POWER:** 100-240VAC, 50-60Hz (TB1-1&2), and ground (TB1-3)
- B: TRIG 01:** 24 VAC-240VAC or 30VDC-100VDC (TB3-1&2) or contact closure at Contact 01 (TB2-1&2)
- C: TRIG 02:** 24VAC-240VAC or 30VDC-100VDC (TB3-3&4) or contact closure at Contact 02 (TB2-3&4)
- D: TRIG 03:** Contact closure at Contact 03 (TB2-5&6)
- E: LOW LEVEL ALARM:** Contact closure at Contact 04 (TB2-7&8)

Primary Power



Dangerous voltages may be present in the enclosure. Refer installation and service to qualified personnel only. Installation must comply with all applicable electrical codes.

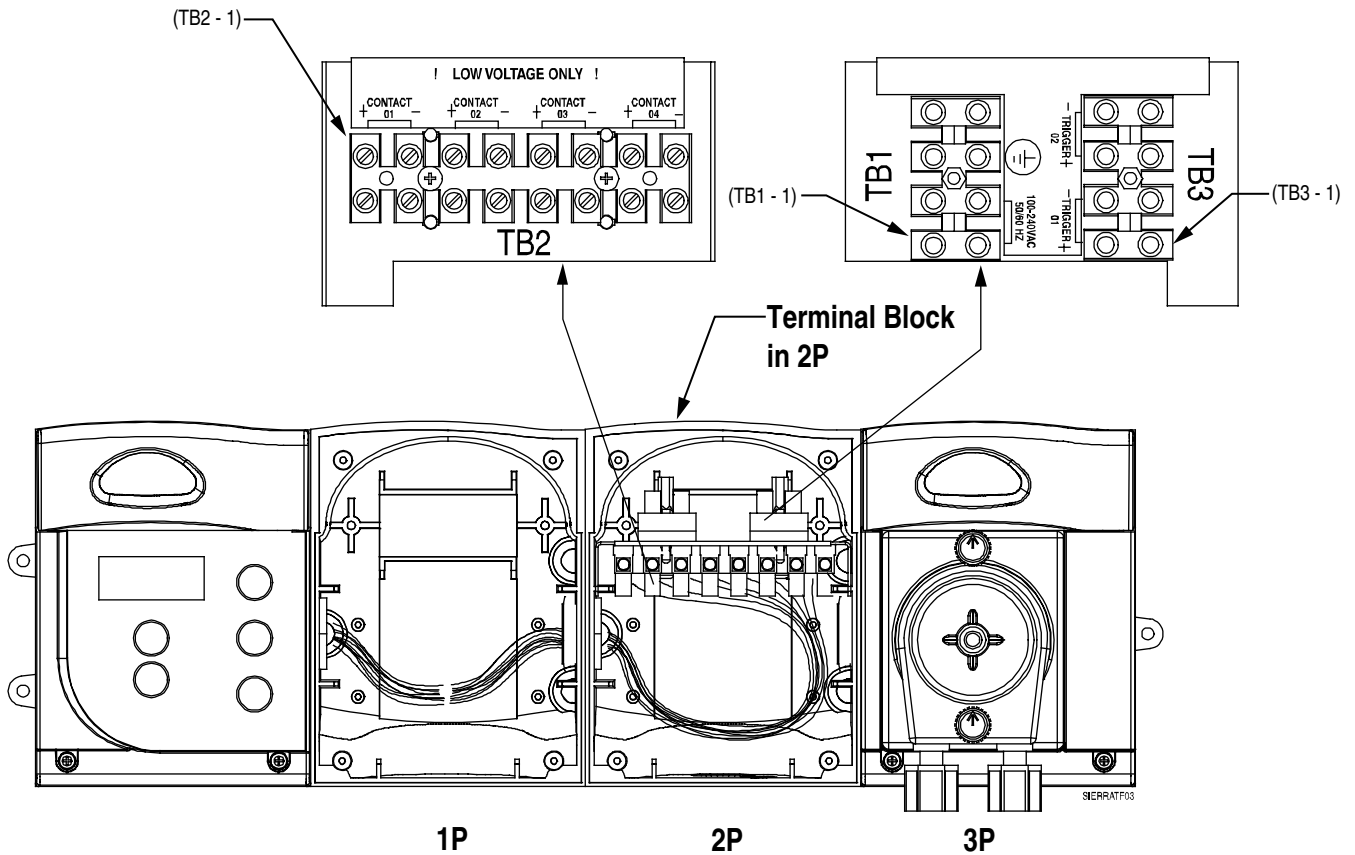
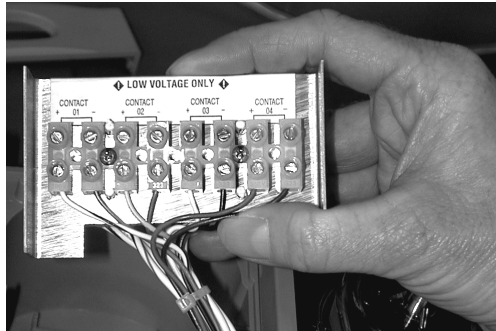

Figure 5. Sierra T Wiring/Removable Terminal Blocks

Figure 5 shows inside of the SierraT, with enlarged images of each terminal block. Terminal blocks may be removed from enclosure for easy access to terminals. Refer to **Table 3** for correct wiring sequences.

Locate electrical circuits that provide power as described in **Specifications**. Constant power must be supplied to the SierraT. Connect the 2 legs of each power source to their appropriate terminals as detailed on the power wiring label. The wire enters through a conduit connector to allow for safe installation.



When using DC triggers, be sure to use correct polarity.

Terminal Block Number	Terminals	Wire Colors	Function
TB1	1	WHT/YEL	POWER
TB1	2	WHT/BRN	
TB1	3	WHT/BLK/GRN	
TB2	1	WHT/BLK	+ CONTACT
TB2	2	ORN	- 1
TB2	3	YEL	+ CONTACT
TB2	4	GRY	- 2
TB2	5	WHT	+ CONTACT
TB2	6	BLK	- 3
TB2	7	RED	+ CONTACT
TB2	8	BRN	- 4
TB3	1	WHT/BLK	+TRIGGER
TB3	2	WHT/BLK/YEL	- 1
TB3	3	WHT/BLK/BLU	+TRIGGER
TB3	4	WHT/ORN	- 2

Table 3. Wiring Connections by Terminal Block

PROGRAMMING PROCEDURES

General

This section describes SierraT's command buttons and the different programming/status screens used to configure your dosing system.



Figure 6. SierraT Touch Pad and Screen

COMMAND KEYS

Key	Description and Function
	This is the UP/DOWN key pair. They are used to select screen options within a menu, to select different screens (such as the Run Screen), or to scroll through digits and select such numbers as setpoints and passcode numbers.
	This is the CURSOR key. It is used to move about the columns on a screen, such as the numbers on the PASSCODE screen (Screen 4).
	This is the ENTER key. It is used to enter another screen level (submenu), start an action such as priming, or cancel an alarm.
	This is the SCROLL key. It is used to move from screen to screen within each Level. Pressing the SCROLL and ENTER keys simultaneously will take the user back to the Run Screen.

Table 4. SierraT Command Keys

SMART SCREENS

SierraT's Smart screens are organized into four different levels (Levels 0 to 3) or "Loops." Each Loop has its own set of programming options, described as follows.

Level 0: The Power Up Screen



Screen 0: Power Up Screen

This is the first screen you will see when you power up the unit. This screen will stay on for approximately one second, and will

then proceed to **Level 1** automatically. The firmware version number appears on the second line of the screen as shown.

Level 1: The “RUN” Loop

Once SierraT has automatically proceeded to **Level 1**, the **Run Screen** (Screen 1) appears. The Run Screen is a default screen that the user programs to appear while the SierraT is running.

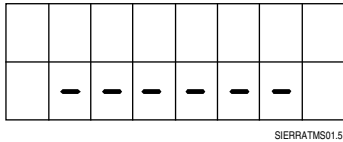

Screen 1. Default Run Loop Screen

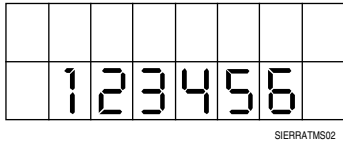

Screen 1. If all triggers are on, this screen appears.

Screen 1 displays diagnostic information, with numbers 1 through 6 each representing different trigger conditions as follows:

No.	Condition
1	High-voltage Trigger 1 is (TB3 - 1 & 2) sensed
2	High-voltage Trigger 2 is (TB3 - 3 & 4) sensed
3	Contact Closure 3 (Trigger 3) is (TB2 - 5 & 6) sensed
4	Contact Closure 1 (equivalent to HVT1) is (TB2 - 1 & 2) sensed
5	Contact Closure 2 (equivalent to HVT2) is (TB2 - 3 & 4) sensed
6	Contact Closure 4 (Low Product) is (TB2 - 7 & 8) sensed
-	Displays instead of a number if that input is not sensed.

From the Run Screen, press the SCROLL key to get to the Prime Pump Screen (Screen 2).

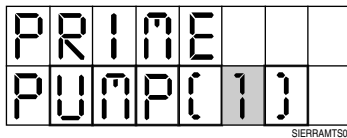

Screen 2. Prime Pump Screen

From Screen 2, press the UP/DOWN arrow keys to cycle through and select desired pump (1, 2, or 3) for priming. The selection will flash once per second. Default is “1”.

If the SierraT is programmed to be in Relay Mode, it will run the selected pump while the ENTER key is depressed.

If the SierraT is programmed to be in Time Mode, press and release the ENTER key once to initiate the preprogrammed dose time. While the pump is running for the preprogrammed time, the selected pump can be stopped by pressing the ENTER key. The programmed delay time will be ignored while priming.

When priming is complete, press the SCROLL key to move to Screen 3 for dosing status.

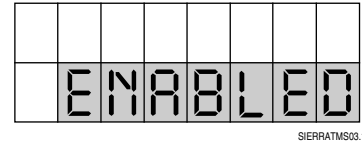

Screen 3. Dosing Screen, Enabled

In Screen 3, pressing the UP/DOWN keys will toggle the screen between DOSING ENABLED or DISABLED. By default, dosing is ENABLED.

When dosing is disabled, the screen will read as shown below, and “DISABLED” will flash continuously, once per second.

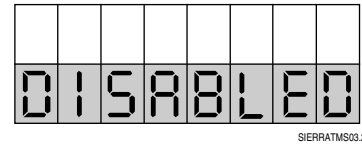

Screen 3. Dosing Screen, Disabled

When dosing is disabled, you will not be able to access any other screens until dosing is again enabled.

When dosing is enabled, pressing SCROLL will take you to Screen 4, the screen that will take you to Level 2, the Configuration Loop.

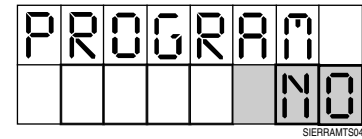

Screen 4. Advance to Level 2 Screen

The UP/DOWN arrow keys toggle between “Yes” and “No”. To advance to Level 2 screens (Screen 5), select “Yes” and press the SCROLL key. Selecting “No” and pressing the SCROLL key will take you back to Screen 1. The selection will flash once per second. Default is “NO”.

Entering the Default Passcode

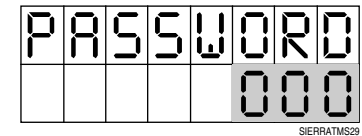

Screen 4a. Password Screen

When you first enter Screen 4a, you will notice that the first of the three zeros is flashing. Since the default password is “000,” you may SCROLL to advance to Level 2.

Entering Programmed Passcode

You may program your own 3-digit passcode (see Screen 9 under **Level 2: The Configuration Loop**). Once you have done this, you will need to enter it on Screen 4a anytime you want to advance to Levels 2. Use the UP/DOWN keys to select the correct numbers, and the CURSOR to advance between the three digits. Press ENTER or SCROLL to advance to Level 2.

If you enter an incorrect passcode, the following screen will appear:

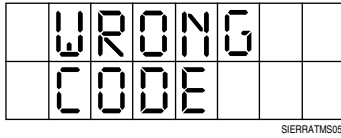

Screen 4b. Wrong Code Screen. Activates if user enters incorrect passcode.

This screen will display for three seconds, and then revert back to the Passcode Screen (Screen 4a). If you don't want to advance to the next level, and just want to work within Level 1, you can press the SCROLL key, or wait 120 seconds. The unit will revert back to Screen 1.

Level 2: The "Configuration" Loop



Pumps will not run while Screens 5 through 10 are displayed.

After entering the correct password from Screen 4a, you will advance to Level 2, the Configuration Loop. The following screen appears:

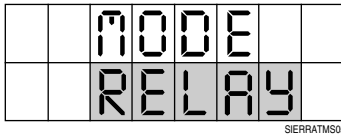

Screen 5. Mode Select Screen

Use the UP/DOWN keys to select RELAY or TIMED mode (default is RELAY mode), and press the SCROLL key to advance to the next screen. Due to the Smart Screen feature, all subsequent configuration screens will apply only to the setting related to your selected control mode. The selection will flash once per second.

The next screen allows you to program a pump delay. Use the UP/DOWN keys to select the pump for which to set a delay time. CURSOR to the bottom line to set a delay time from 000 to 999 seconds.

Default pump is "1". Default delay is "000". The default active selection is the Pump Selection (top row), and will flash once per second. When you press the CURSOR key to change the delay time, the first of three zeros will flash. Use the CURSOR key to select the other digits or to move back up to the top row to select the pump number.

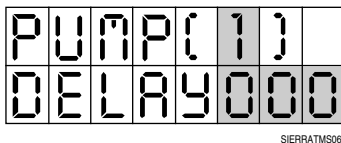

Screen 6. Set Pump Delay

Once delay times are set, pressing the SCROLL key when the CURSOR is in any position will advance the SierraT to the Run Time screen (in TIME mode) or the Trigger screen (in RELAY mode).

Setting Pump Run Time (Time Mode Only)

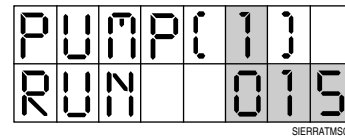

Screen 7. Setting Pump Run Time

Selected digit will flash once per second. Using the UP/DOWN and CURSOR keys, select the pump number and enter desired pump run time from 000 to 999 seconds (default is 15 seconds).

Defining Pump/Trigger Assignments

This screen allows you to assign trigger actions to pumps.

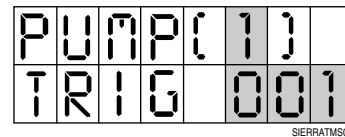

Screen 8. Defining Pump/Trigger Assignments

Use the UP/DOWN keys to toggle between Pumps 1, 2, and 3. CURSOR to the bottom line and use the UP/DOWN keys to toggle between Trig 01, 02, and 03.

Any one trigger can be assigned to any pump. Pump 1 can be assigned to either Trigger 1, Trigger 2 or Trigger 3. Pump 2 can be assigned to either Trigger 1, Trigger 2 or Trigger 3. Pump 3 can be assigned to either Trigger 1, Trigger 2 or Trigger 3. Trigger 1 is either TB3-1&2 or TB2-1&2. Trigger 2 is either TB3-3&4 or TB2-3&4. Trigger 3 is only TB2-5&6.

By default, Pump 1 is assigned to Trig 1, Pump 2 to Trig 2, and Pump 3 to Trig 3. If a pump has "Trig 000" assigned, then that pump will be disabled, and will not activate with any triggers.

Setting Password

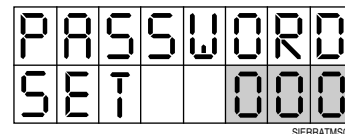

Screen 9. Setting Password

Use Screen 9 to set and change your password. Using the UP/DOWN and CURSOR keys to enter a password between 000 and 999 (default is "000"). Selected digit will flash once per second.

Exit Screen

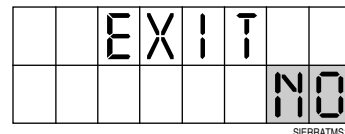

Screen 10. Exit Screen

Screen 10 gives you the option to either exit back Level 1. A "NO" response will bring you back to Screen 5, and a "YES" response will bring you back to Screen 1. Use the UP/DOWN keys to select, and SCROLL key to execute "YES" or "NO". Default is "NO". The active selection will flash once per second.

Low Product Alarm

When the system detects a low-product condition, a low-product alarm activates, and the following screen appears:

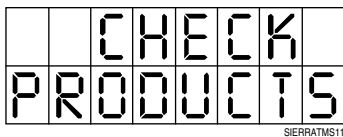

When this screen activates, it will flash at one-second intervals, alternating with the following screen:

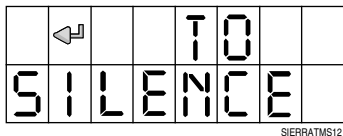

Once you have silenced the alarm by pressing the ENTER key, the menu will return to Screen 1. The alarm will be locked out for five minutes, and the system will continue to operate normally. If the alarm condition still exists after five minutes, the alarm will activate again. To use the alarm with multiple products, the contact closure can be wired in parallel. See **Accessories and Spare Parts** section for recommended Low Level Alarm Lance.

MAINTENANCE



TURN OFF all power before servicing.

Servicing Interior Components

To access interior, slide top cover up and gently pry off. It may be necessary to pry the cover off with a flat-head screwdriver. If this is necessary, take care not to damage the unit. Then remove the four screws.

Pump & Squeeze Tube Replacement Schedule

Since every installation is different (chemicals, tube runs, operating frequency, etc), an exact tube replacement schedule cannot be specified. With use, the tube slowly evolves from round to oval and the amount of chemical pumped decreases. By regularly checking the amount of chemical pumped, you can determine general tube life. We recommend that you closely monitor the time it takes the original tube to reach the end of its flex life, and then establish a replacement schedule. Replacing tubes at regularly scheduled intervals ensures more accurate product use and reduces service calls. In general, using short feed lines of a large diameter will improve pump tube life.



It is very important not to let the tubes become worn to the point where they tear and allow chemicals to saturate the pump housing.

How to Replace Pump Cartridges and Squeeze Tubes

Only the cartridge replacement should be done in the field. Tube replacement can be accomplished later. Note that each product has different delivery line configurations and squeeze tubes. Refer to the **Table 2** in the **Installation and Setup** section under **Connecting Chemical Supply Lines** for the available tubing sizes. Refer to the **Specifications** for tubing materials.

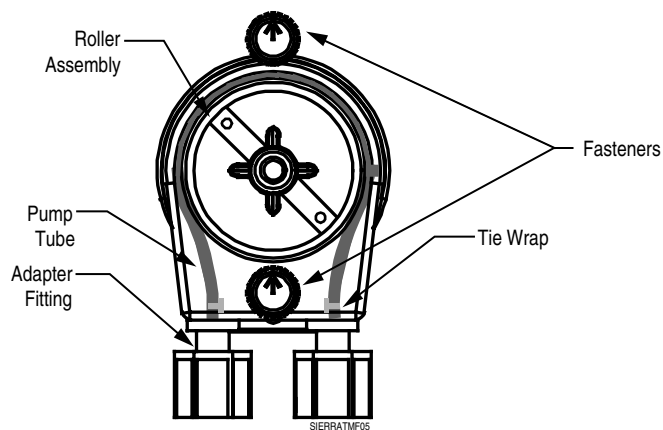

Figure 7. SnapHead Pump

To Remove

1. Disable unit, or turn off main power.
2. Remove the cartridge from the motor housing by twisting the two quarter turn fasteners at top and bottom counterclockwise while gently pressing.



Wear adequate protective clothing such as gloves and safety goggles.

3. Remove the supply and feed lines from the old pump squeeze tubing and connect them to the new pump squeeze tubing.

To Install

1. Disable unit, or turn off main power.
2. Align and engage the pump drive spline with the motor gear.
3. Turn the fasteners so that arrows are pointing upward.
4. Hold the cartridge vertically and press the fasteners into the motor housing until you hear a distinct click.



It is very important that the tabs are vertical and that you press them firmly enough to hear them click. Incorrect installation could damage the pump.

How to Change the Pump Squeeze Tubing

1. Remove the cartridge as described above.
2. Remove the small screw at the bottom of the rear cover and lift the cover from the cartridge.
3. Pull the adapter fittings rearward until they clear the cartridge.
4. Pull the roller assembly rearward to release the pump squeeze tubing.
5. Cut the tie wraps holding the pump squeeze tubing to the adapter fitting and pull the tubing from the fittings.
6. Replace the pump squeeze tubing making certain to use the proper size tube.
7. Push the adapters on to the ends of the tubing and secure with tie wraps. Make certain that the "buckles" of the tie wraps are both facing the same direction. This will keep the tube from twisting in the cartridge.

8. When using B-Flex tubing, coat the inside of the cartridge with a liberal amount of Silicone 111 lubricant.
9. Press the 2 adapter fittings into the cartridge so that the tie wrap "buckles" face toward the center of the pump.
10. Push the roller assembly onto the cartridge shaft using a twisting motion to engage the rollers properly with the pump squeeze tubing.
11. Return the rear cover and secure with the small screw at the bottom. The flat side of the cover should face inward.

How To Replace Pump Motor Subassemblies

To Remove

1. Ensure power and all triggers are off/disabled.
2. Remove the pump cartridge from the motor assembly, leaving the chemical lines attached.
3. Remove the electrical connections at the back of the motor.
4. Compress the two flex ears on the back of the motor until the motor slides out through the hole in the cabinet.
5. For detailed information on SierraT subassembly structure, please see **Appendix B**.

To Replace

1. Ensure power and all triggers are off/disabled.
2. Locate the alignment tip of the pump motor housing so it is in the down position.
3. Slide the pump motor housing into the enclosure hole. The holding ears will expand to hold the pump motor/solenoid in place. Verify that both ears popped out and are locked in place.
4. Reinstall the electrical connections at the back of the motor (Refer to **Appendix B** for wiring diagram).
5. Install the pump cartridge.
6. Prime the pump to verify proper pump rotation (clockwise). If the direction is wrong, switch the motor wires.

TROUBLESHOOTING

Refer to the assembly drawings and the complete unit wiring diagram in the **Appendix B**. To order replacement spares, see **Accessories and Spare Parts**. Please order using the item number.

No Power



The following procedure is to be performed only by qualified personnel.

Check the following:

1. Check power supply terminal strip connection (TB1-1,2) and verify that there is appropriate line voltage.
 - a) If there isn't appropriate line voltage, check wiring and power supply.
 - b) If there is appropriate line voltage, proceed to Step 2.
2. Confirm connection CN1 is firmly seated on the power supply board. If firmly connected and the SierraT is still not functioning remove CN1 and confirm that appropriate line voltage (100-240VAC) is present on the input wire.

If there isn't appropriate line voltage is present, check wiring between CN1 and TB1. If there is appropriate line voltage, proceed to Step 3.

3. Reconnect CN1. Disconnect J2. Confirm that appropriate input voltage (24VDC) is present.
 - a) If there isn't appropriate line voltage, replace SierraT power supply PCB.
 - b) If there is appropriate line voltage, replace SierraT controller PCB.

Chemical Feeds Too Often/Too Much Chemical Used

Check the chemical control setup and harness. (Refer to the original setup records.) If wrong, correct. If OK, replace the PCB.

Chemical Does Not Feed at All (Pump Doesn't Turn)

1. Check the chemical control setup, including setup menus and input triggers. (Refer to the original setup records.) If wrong, correct.
2. Use voltmeter to verify 24 VDC is present on pump driver wires while priming. If 24 VDC is present, replace pump motor. If 24 VDC is not present, disconnect harness and test at PCB output. If 24 VDC is not present at PCB output, replace PCB; if present, replace harness.

Chemical Pump Feeds Continuously

Check the preset run time of the pump and the operation of the prime button. If the pump continues to run beyond that run time, check the wiring harness. If pump still feeds continuously, replace the SierraT Main PCB.

Pump Will Not Pull the Chemical Out of the Drum

1. Too much vacuum created. The supply line in the chemical drum may be up against either the side or bottom, the supply lines may be too long for a viscous product, or there may be a crimp in the intake supply line, thus exceeding the pump's vacuum specifications.
2. There may be an air leak somewhere in the input supply line. Most often this is caused by inadequate sealing of the supply line into the line nuts. See **Installation and Setup** section for recommended procedure.
3. Squeeze tube is worn and the rollers can no longer squeeze the tube properly. Correct by changing the pump cartridge with the correct size squeeze tube and line nuts for the chemical being pumped.

ACCESSORIES & SPARE PARTS

The items listed in this section provide you with quick reference numbers for some of the major parts and accessories. A complete exploded assembly drawing is located in the back of the manual.

Spare Parts and Accessories

Mounting Bracket	069188
Power Supply PCB 100-240 VAC	087751
Main PCB	1200456
1/2" Watertight Plastic Conduit Elbow	068529
1/2" Plug	041236
7/8" Plug	041235
1/2" Strain Relief, 0.114" – 0.250" Nylon	032121
3/4" Strain Relief, 0.23" – 0.55" Nylon	090369
Low Level Alarm Lance	091518
Chemical Tubing Standpipe	036857
Poly Single-Wall Bulkhead Fitting, 70°, 5/8" ID Tube, Barb	035542
Poly Double-Wall Bulkhead Fitting, 70°, 23mm OD Tube	051177
Poly Double-Wall Bulkhead Fitting, 90°, 6mm OD Tube	063927
Poly Single-Wall Bulkhead Fitting, 90°, 1/4" PD Tube	022031



Call Technical Support or Customer Service for complete listing of available chemical tubing, bulkhead and injector fittings, check valves and other installation materials.

Pump Spares

B Flex

Pump cartridge, B Flex, detergent	092963
Tubing, 0.250 ID, B Flex, detergent	069943
Insert, detergent, 1/4-inch barb	056581
Tube kit, B Flex, 1/4-inch barb	092847

Norprene

Pump cartridge, Norprene, detergent	039556
Tubing, 0.188 ID, 150 ml Norprene, detergent	037617
Insert, detergent, 1/4-inch	036969
Tube nut, compression, 1/4-inch	043823
Tube kit, Norprene, 1/4 inch	039553

Medium and Low Flow Pump Spares

B Flex

Pump cartridge, B Flex, rinse	092995
Tubing, 0.063 ID, B Flex, rinse	091756
Insert, rinse, inlet, 1/4-inch	036982
Tube nut, compression, 1/4-inch	043823
Insert, rinse, outlet, 1/8-inch	036982
Tube nut, compression, 1/8-inch	017458
Tubing, 4mmT - 4mmT, Flex, rinse	097683

B Flex

Pump cartridge, B Flex, sanitizer	092854
Tubing, .125 ID, B Flex, sanitizer	091757
Insert, sanitizer, inlet, 1/4-inch	090331
Tube nut, compression, 1/4-inch	043823
Insert, sanitizer, outlet, 1/4-inch	090331
Tube nut, compression, 1/4-inch	043823

Miscellaneous Pump Spares

Pump Roller Assembly	039550
Quarter Turn Pin for Pump (10 pack)	050670
Pump Motor Gearbox	051351
Standpipe	036857



Pump tubes are also available in Norprene, Nordel, Silicone, C-Flex, and Viton.

TECHNICAL ASSISTANCE

If you require additional technical information, contact our Technical Support Department at 1-800-468-4893. From Europe, please call 0800-052-4726.

RETURNING EQUIPMENT FOR REPAIR

If you need to send an item back to be repaired, you must call or write to obtain a Returned Authorization (R.A.) Number before sending it back. Please write the R.A. number on the outside of the box before sending it back. It is also very helpful to our repair department if you include a note inside the box explaining the nature of the problem. Failure to obtain a Return Authorization Number before sending an item in for repair or replacement may delay the return of your equipment, and a \$25 handling fee will be incurred.

APPENDIX B: ASSEMBLY DRAWINGS

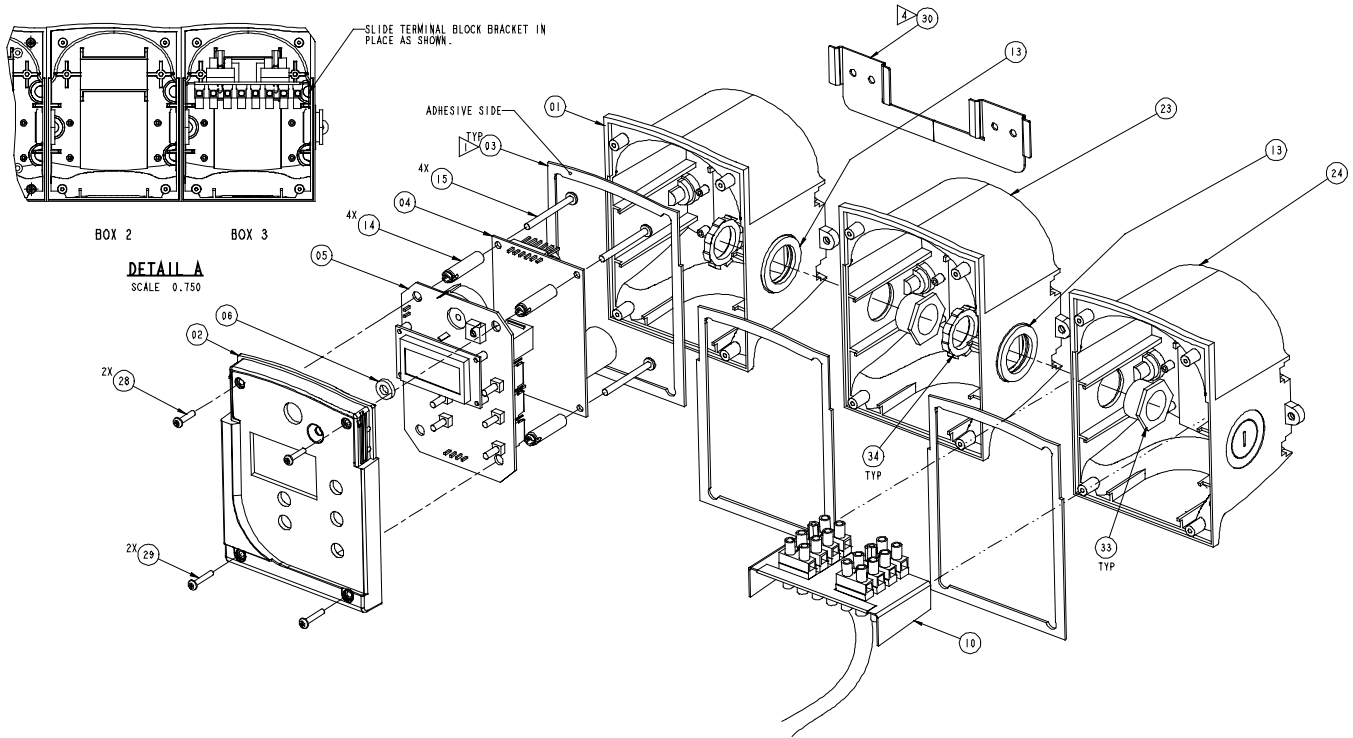

Seq #	Description	Code#	Seq #	Description	Code#
01	ENCL,BUCKET,,HOLE B,GRY	1200398	13	WSHR,FL,1.25ODX.88IDX.13, NRPN	069180
02	ENCL,BEZEL,CONT,SIERRA, GRY	069974	14	SPCR,SNP,9/32RND,#6X1,NYL	069135
03	GSKT,ENCL,ADH	069630	15	SCR,T-B,PH PNH,#6X1-1/2,ZP STL	068516
04	PCB ASSY,PWR SPLY, 90-264VAC,	087751	23	ENCL,BUCKET,HOLE AB,GRY	1200397
05	PCB ASSY,SIERRA T	1200456	28	SCR,T-B,PH PNH,#4X1/2,SST	099688
06	GSKT,LED,NPRN,PSA	087415	29	SCR,T-B,PH PNH,#4X5/8,SST,BLK	099689
10	HARN,PWR/IO,SIERRA,CSA	069653	30	BRKT,MTG,SIERRA	069188
			33	CFTG,NIP,CHASE,1/2",STL	069665
			34	NUT,LK,1/2,CND	041077

APPENDIX B: ASSEMBLY DRAWINGS

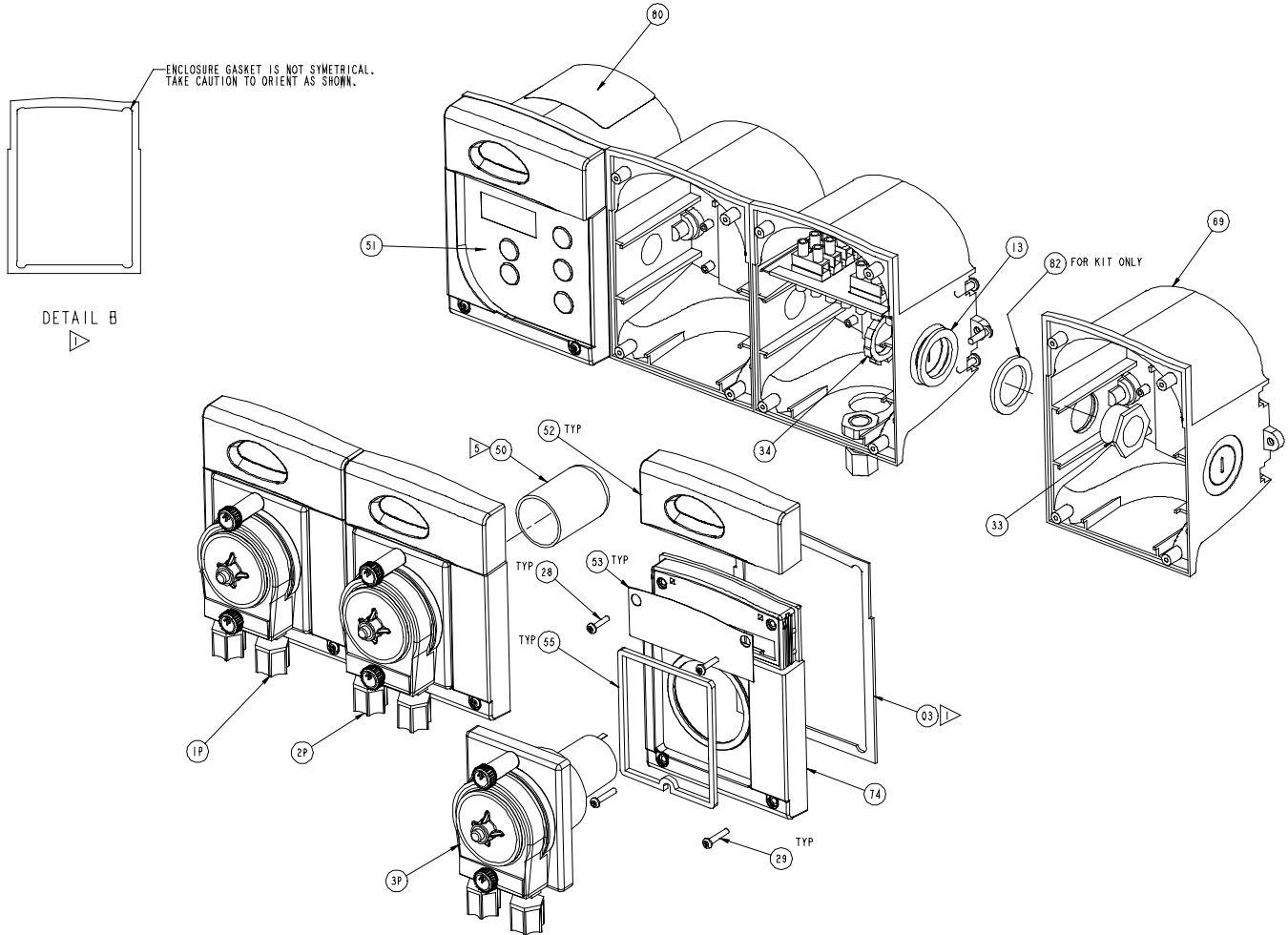

Seq #	Description	Code#	Seq #	Description	Code#
24	ENCL,BUCKET, HOLE AB,GRY	1200397	1P	PMP PS/A,5 OZ,24VDC, W/NEW HSG	See Note A
51	LBL,CVR,CONT,SIERRA , BETA	069379	1P	NRPRN,,188ID,1/4T-1/4T	See Note A
53	LBL,CVR,PMP,SIERRA,BETA	1201098	2P	PMP PS/A,5 OZ,24VDC, W/NEW HSG	See Note A
69	ENCL,BUCKET, HOLE A,GRY	1200411	2P	NRPRN,,188ID,1/4T-1/4T	See Note A
74	ENCL,BEZEL,PMP MDL, SIERRA,GRY	069975	3P	PMP PS/A,5 OZ,24VDC, W/NEW HSG	See Note A
			3P	NRPRN,,188ID,1/4T-1/4T	See Note A

NOTE A: SEE SPARE PARTS AND ACCESSORIES FOR COMPLETE PUMP OPTIONS

APPENDIX B: ASSEMBLY DRAWINGS

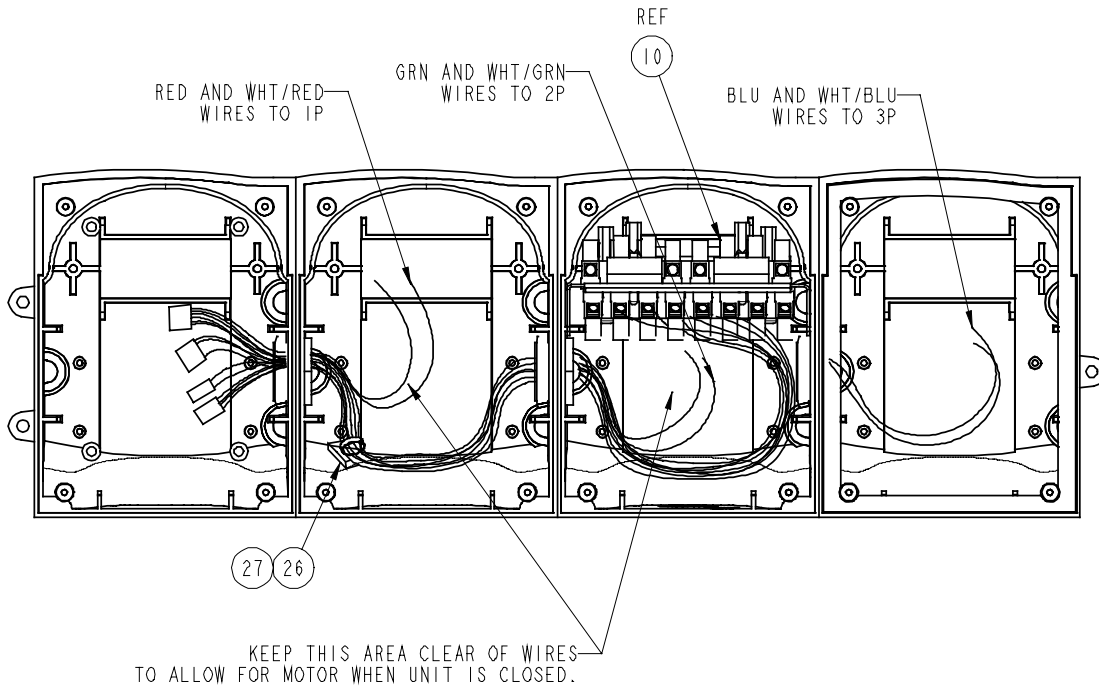

WIRE ROUTING

SCALE 0.750

Seq #	Description	Code#
0010	HARN,PWR/IO,SIERRA,CSA	069653
0012	HARN,24VDC,SIERRA	087974
0026	TIWRP,AHR,ADH,RB,3/4", NYL,NAT	041323
0027	TIWRP,.10X4L,NYL,NAT	041318
0050	CAP,MOT,1.06IDX1.60LX.06 TH	068648
0052	ENCL,DOOR,ABS,GRY	087659

APPENDIX B: ASSEMBLY DRAWINGS

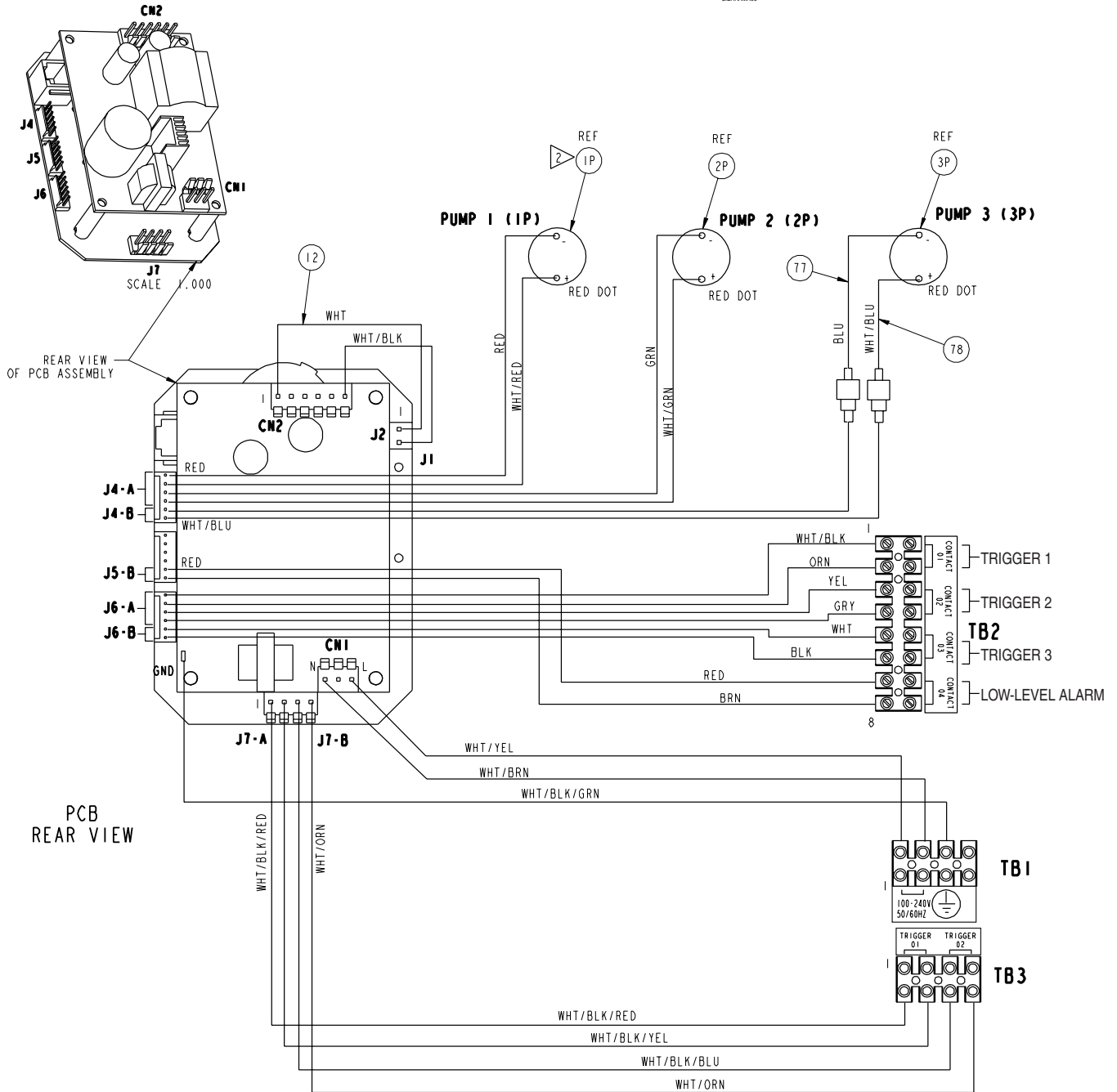
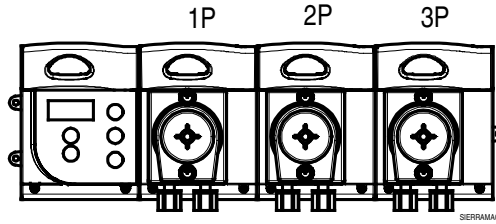

Beta Technology, Inc
 2841 Mission Street
 Santa Cruz • CA
 U.S.A. • 95060

TEL • 831 • 426 • 0882
 TEL • 800 • 858 • 2382
 FAX • 831 • 423 • 4573
 FAX • 800 • 221 • 8416

TEL (U.S. and Canada) • 800 • 468 • 4893
 TEL (outside U.S. and Canada) • 410 • 228 • 1292
 Tech Support
 sales@beta-technology.com

Beta Technology, Inc
 4 Finway, Dallow Road
 Luton LU1 1TR
 United Kingdom

Freephone • 0800 • 052 • 4726
 Tel • +44(0) • 1582 • 526600
 Fax • +44(0) • 1582 • 526111
 Freephone • 0800 • 052 • 4726
 VAT REG. NO. BG.354 • 09975 - 44

Customer Service
 Tech Support
 europe.sales@beta-technology.com
 Online Ordering: <http://www.beta-technology.com>

Beta Technology is ISO9001 Certified