

# Sprayballs for Industrial Applications



Beta Technology's line of Sprayballs covers a broad range of CIP applications found in the Dairy, Brewing, and the Food and Beverage Industries. Each of our Sprayballs are precision designed and machined to create the turbulent falling film necessary for optimum cleaning at 1 bar pressure (14.7 PSI). They are manufactured from 316 Stainless Steel, are fully self-draining and self-cleaning, and are finished to a hygienic standard both externally and internally. 316 stainless steel tension clips gives simple and secure fixing. Designed and manufactured to produce extremely accurate flow patterns, Beta Technology's Sprayballs are well engineered and proven in the field.

## KEY BENEFITS

- Variety of sizes and flow rates to accommodate a broad range of cleaning applications
- Rugged, resilient stainless-steel construction
- TIG welded without filter rod to avoid contamination
- Fully self-draining and self-cleaning
- Finished to hygienic standard both internally and externally
- Special range of sprung stainless steel clips gives simple and secure fixing



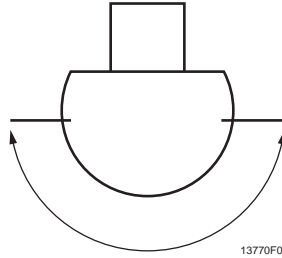

KC13770P02



**TYPE KC**  
OPEN TOPPED VESSELS  
180° COVERAGE

**"KC" Type Sprayballs - for Open Tanks Requiring 180° Downward Spray**

Usage	Inch Sprayballs Type	Ball Dia./Spigot Dia.	Flow Rate	Spray Pattern	Item #
Open tanks requiring 180° spray	KC	2.5"/1"	129 l/m 34 gpm (U.S.) @15psi (1 bar)		064206
Open tanks requiring 180° spray	KCUK	2.5"/1"	68 l/m 18 gpm (U.S.) @15psi (1 bar)		064199

13770T01



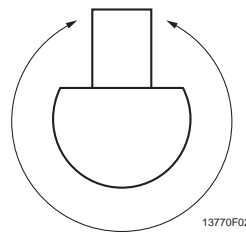

JC13770P03



**TYPE JC**  
360° COVERAGE

**"JC" Type Sprayballs - For 360° Coverage**

Usage	Inch Sprayballs Type	Ball Dia./Spigot Dia.	Flow Rate	Spray Pattern	Item #
Vertical or horizontal tanks up to 3m dia. or 2.5m long	JCUK	2.5"/1"	95 l/m 25 gpm (U.S.) @15psi (1 bar)		064196
Vertical or horizontal tanks up to 3m dia. or 2.5m long	JC	2.5"/1"	167 l/m 44 gpm (U.S.) @15psi (1 bar)		064203
Vertical or horizontal tanks 3m dia. or 2.5m long	JCUS	2.5"/1"	273-318 l/m 72-84 gpm (U.S.) @15psi (1 bar)		017306

13770T02



HC13770P04

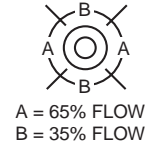
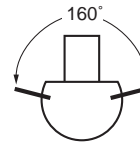
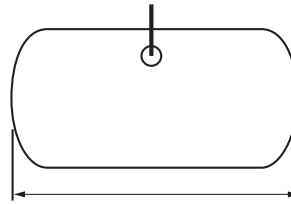

13770F03

### "HC" Type Sprayballs - For Horizontal Tanks

Usage	Inch Sprayballs Type	Ball Dia./Spigot Dia.	Flow Rate	Item #	Metric Sprayballs Type	Ball Dia./Spigot Dia.	Flow Rate	Item #
Horizontal tanks up to 1.5m long	HC125-1.0	2.5"/1"	125 l/m 33 gpm (U.S.)	064717	HC125-25	63 mm/ 25 mm	125 l/m 33 gpm (U.S.)	064720
Horizontal tanks up to 3m long	HC250-1.5	3.5"/1.5"	250 l/m 66 gpm (U.S.)	064718	HC250-40	90 mm/ 40 mm	250 l/m 66 gpm (U.S.)	064721
Horizontal tanks up to 6m long	HC500-2.0	3.5"/2.0"	500 l/m 132 gpm (U.S.)	064719	HC500-50	90 mm/ 50 mm	500 l/m 132 gpm (U.S.)	064723

13770T03



ZC13770P05

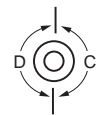
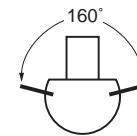
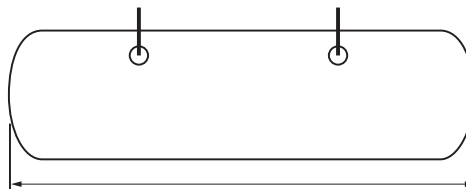

C = 65% FLOW  
D = 35% FLOW

13770F04

### "ZC" Type Sprayballs - For Long Horizontal Tanks

Usage	Inch Sprayballs Type	Ball Dia./Spigot Dia.	Flow Rate	Item #
Horizontal tanks up to 3.0 m long	ZC125-1.0	2.5"/1"	125 l/m 33 gpm (U.S.)	064732
Horizontal tanks up to 6.0 m long	ZC250-1.5	3.5"/1.5"	250 l/m 66 gpm (U.S.)	064733
Horizontal tanks up to 9.0 m long	ZC500-2.0	3.5"/2.0"	500 l/m 132 gpm (U.S.)	064734

13770T04



VC13770P0

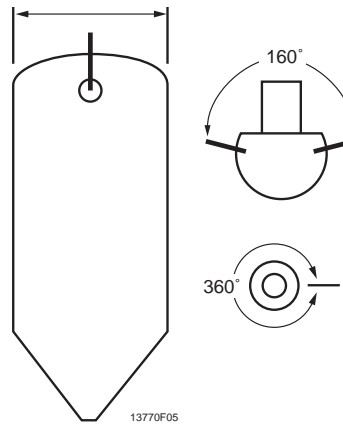

13770F05

**"VC" Type Sprayballs and their Applications - For Vertical Tanks**

Usage	Inch Sprayballs Type	Ball Dia./ Spigot Dia.	Flow Rate	Item #	Metric Sprayballs Type	Ball Dia./ Spigot Dia.	Flow Rate	Item #
Vertical tanks up to 1.5 m dia.	VC125-1.0	2.5"/1"	125 l/m 33 gpm (U.S.)	064724	VC-125-25	63 mm/ 25mm	125 l/m 33 gpm (U.S.)	064728
Vertical tanks up to 3.0 m dia.	VC250-1.5	3.5"/1.5"	250 l/m 66 gpm (U.S.)	064725	VC-250-40	90 mm/ 40 mm	250 l/m 66 gpm (U.S.)	064729
Vertical tanks up to 6.0 m dia.	VC500-2.0	3.5"/2.0"	500 l/m 132 gpm (U.S.)	064726	VC500-50	90 mm/ 50 mm	500l/m 132 gpm (U.S.)	064730
Vertical tanks up to 9.0 m dia.	VC750-2.0	3.5"/2.0"	750 l/m 198 gpm (U.S.)	064727	VC750-50	90 mm/ 50 mm	750 l/m 198 gpm (U.S.)	064731

13770T05



FC13770P07



180° COVERAGE

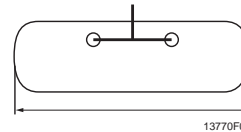

13770F06

**"FC" Type Sprayballs - for Tanker Trucks, 180° Spray**

Usage	Inch Sprayballs Type	Ball Dia./Spigot Dia.	Flow Rate	Item #
Horizontal tanks up to 8.5m long using 2 FC Sprayballs	FC	2.5"/1"	2 Heads 261 to 598 l/m 69 to 158 gpm (U.S.) @11 to 53psi	064216

13770T06

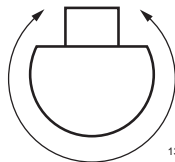

13770F07

**TYPE SC**  
SMALL 40mm BALL  
360° COVERAGE

**"SC" Type Sprayballs - Multi-purpose 360° Sprayball for Specialized Cleaning Jobs**

Usage	Inch Sprayballs Type	Ball Dia./Spigot Dia.	Flow Rate	Spray Pattern	Item #
Vertical or horizontal tanks 3m dia. or 2.5m long	SC	1.6"/0.75"	55 l/m 14.5 gpm (U.S.) @15psi (1 bar)		064190

13770T07



SC13770P08