

Installation Instruction

Flush Manifold



Fittings are factory-tightened. Do not tighten them or you will cause them to leak, either by breaking the megalock seal or damaging the threads.

INTRODUCTION

This instruction sheet covers the 3-port, 5-port and 8-port flush manifold. These manifolds are designed to work with the OPL and E dispensers. A separate XL flush manifold is available for use with the XL dispenser.



You cannot use these flush manifolds with the XL.

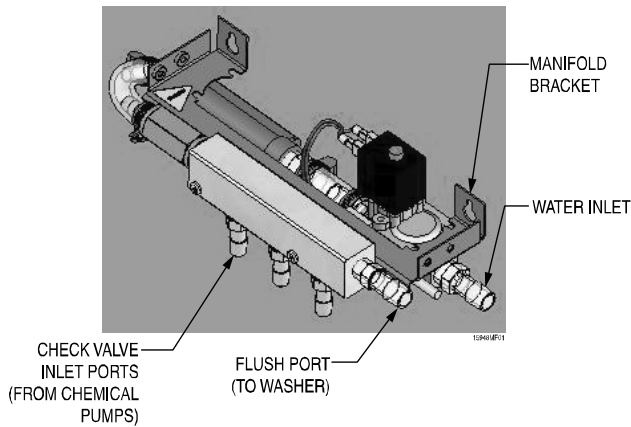

Figure 1. 3-Port E Flush Manifold

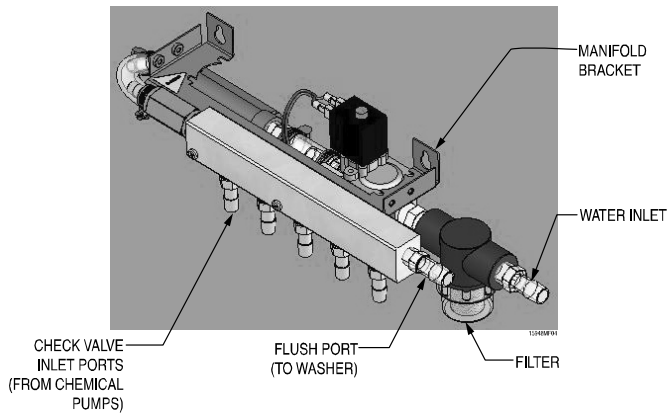

Figure 2. 5-Port E Flush Manifold

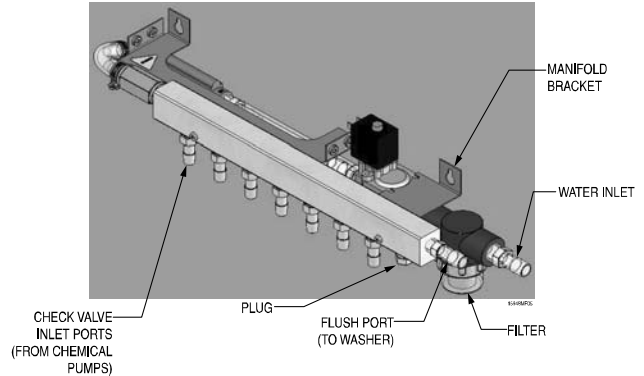

Figure 3. 8-Port E Flush Manifold

MANIFOLD INSTALLATION

E flush manifolds come with wall-mount keyholes pre-drilled in the manifold bracket. Additional stainless steel mounting brackets are included for under-dispenser mounting, if desired. White check-valve manifolds should always be mounted with the check valves positioned under the manifold (pointing up into it) as shown in Figures 1-3.

Gray check-valve manifolds are the opposite; they must be mounted with the check valves positioned over the manifold, pointing down into it.

- Verify that the dispenser is off by disconnecting the power and turning the switch off (the LED should not be lit).
- The flush manifold comes with mounting (manifold) brackets already assembled to the manifold.

Mounting on the Wall

For best results, center the manifold under the dispenser, about 8 to 10 inches below it. This will allow adequate space for the wiring harness, which limits the allowable distance between manifold and dispenser.

1. Position the manifold under the E dispenser allowing adequate space for delivery lines and easy servicing.
2. Fasten the manifold to the wall using the keyhole slots in the mounting bracket. Use screws that are appropriate for the wall surface.

Mounting Beneath the Dispenser

1. Attach the dispenser mounting brackets to the underside of E unit using the 4 screws provided.
2. Connect the manifold to the dispenser brackets via the manifold brackets using the other 4 screws provided.

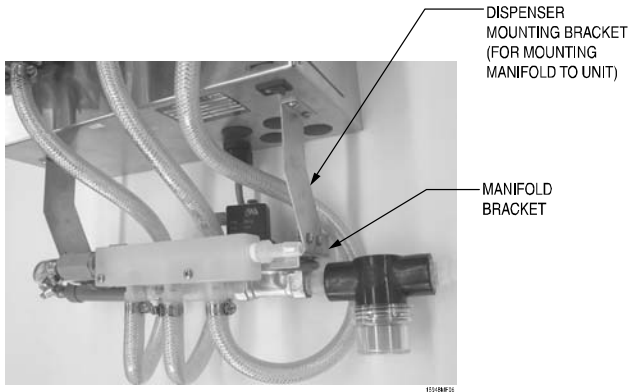

Figure 4. Mounting Manifold to E Unit

- You may install a flush system up to 30 meters (100 feet) from the washer. This distance is based on using 12 mm or 1/2-inch tubing. Some customers have obtained satisfactory results with the manifold as far as 200 feet (60 meters) from the washer.
- You may need to reduce distance to compensate for the effects of high-viscosity products.

Plumbing



- We recommend that you use 1/2" ID inlet tubing and 1/2" ID outlet tubing.

- Connect the water inlet tubing to the manifold (see Figures 4-6).
- Remove check valves that are not being used and replace them with plugs (extra plugs are provided).
- Connect the chemical lines from the outlet side of the chemical pumps to the check valves on the manifold and fasten them with hose clamps. Be sure to leave sufficient slack in these lines to allow service access.
- Connect the outlet tubing to the flush port and fasten with a hose clamp.



IMPORTANT: E manifolds are designed to operate at dynamic water pressures between 15 and 60 psi (1-4 bar). For optimal performance, inlet pressure should be set higher than 20 psi (1.4 bar). This will allow for adequate flow, even during pressure/flow fluctuations that occur during normal laundry operation.

If inlet dynamic water pressure falls below the minimum of 15 PSI, the flow rate is assumed to be less than 0.3 gallons (1.1 liters) per minute. The unit will stop pumping and will display a "No Flow" error.

Wiring

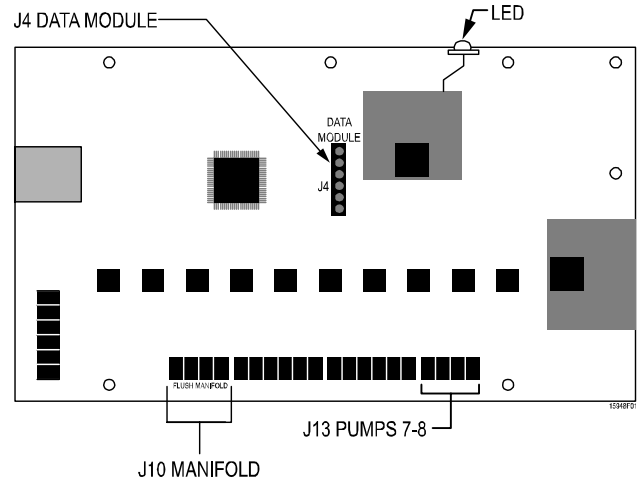

Figure 5. Dispenser Main PCB, Component Locations

- Pass the wire harness through one of the available holes in the bottom of the dispenser.

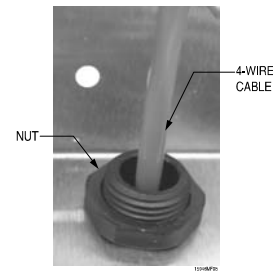

Figure 6. Wire harness passing through bottom of dispenser, held in place with nut

- Place the nut over the wire and gently tighten.
- Connect the 4-pin Molex connector to the 4-pin position on the-PCB harness adapter.
- Connect PCB harness adapter to the position on the Main PCB labeled **Manifold**.

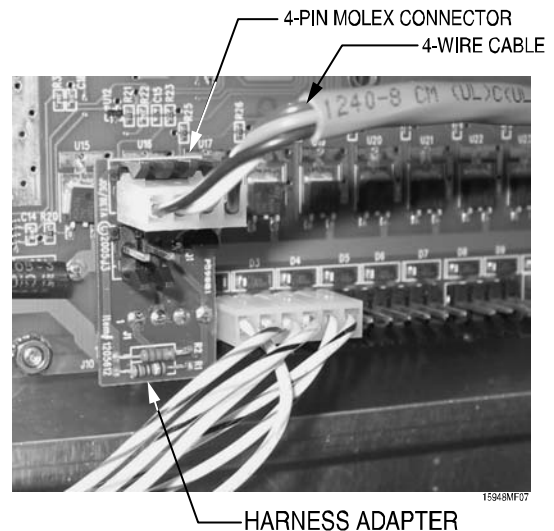

Figure 7. 4-pin Molex connector connected to PCB harness adapter, which is connected to MANIFOLD on the main PCB

5. Use tie wrap provided and wrap base to secure the wire inside the dispenser housing and provide additional strain relief.
6. Adjust the length of the cable/wires as needed and tighten the strain relief nut.
7. Once these things have been done, follow the steps for programming in the E and XL Installation and Operation manual.



Manifold comes pre-wired. However, if you ever disconnect the wiring it is important that the specified groups of wires go to the area on the manifold specified below. Polarity of the wires within these parameters is not important.

1. *From harness: black and white wires go to flow switch.*
2. *Red and green wires go to solenoid.*

PROGRAMMING

When the old OPL and E dispensers are connected to an E flush manifold, the dispenser recognizes the manifold and manifold programming screens will appear in the programming menus.

If these menus do not appear, the manifold is not properly connected and will not function.

Program the manifold as described in the **E and XL Installation and Operating Manual**.

SAFETY



It is important that incompatible chemicals not be injected into any flush manifold together.

To prevent the mixing of any chemicals, the old OPL or E dispenser, in combination with the E flush manifold, will flush the manifold with water before and after chemicals are pumped. Despite this safeguard, you must not run sour and bleach or other incompatible chemicals together into the manifold. Instead, route one to the manifold and the other downstream via a separate delivery line. A Sour Flush Kit (#069505) is available for this type of installation.

Extra plugs are provided with the E flush manifolds to plug any port that is not in use. Unused ports should always be plugged. The 8-port E manifold comes with one port plugged. Additional check valves are included with the 8-port E manifold in the event that an eighth, non-reactive chemical is to be injected into the manifold.